

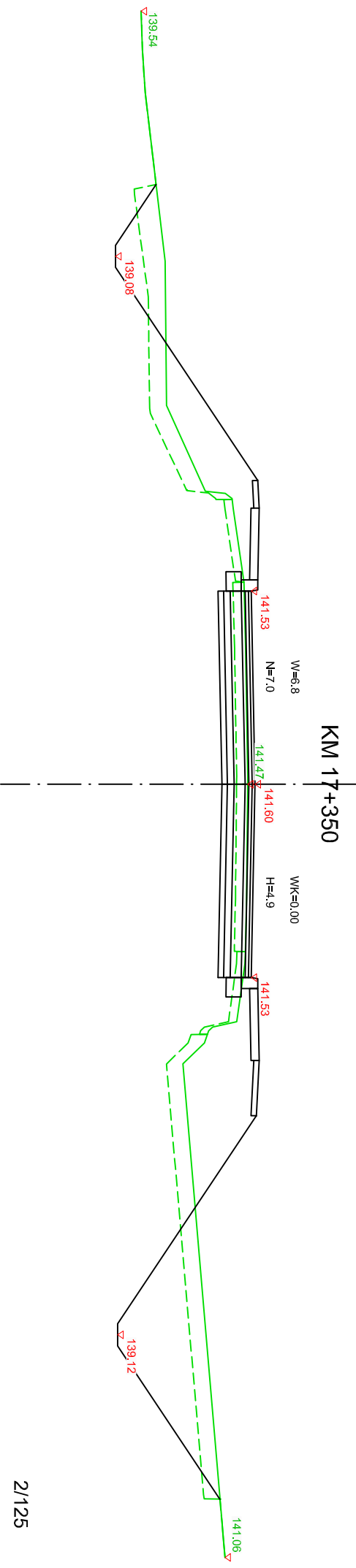

**Kozłowski**  
BUREAU OBSŁUGI INWESTYCYJCI DROGOWYCH

**KOMI Z. Kozłowski**  
15 - 274 Białystok ul. Waszyngtona 24 lok. 15  
tel/fax 085 74 20 117; tel kom. 600 207 447  
email: phukomi@op.pl

Nazwa rysunku:	PRZEKROJE POPRZECZNE	Skala:	1:100
Inwestor:	Podlaski Zarząd Dróg Wojewódzkich	Data:	III 2011.
Objekt:	Dr. Woj. Nr 671 na odcinku Janów - Korycin	Nr rysunku:	5
Stadium:	PW		
Branża:	DROGI		
Projektował:	Nr upr.	Podpis	
mgr inż. A. Kalinowski	PDL/0036/POOD/09		
Sprawił:			
mgr inż. P. Jakubecki	PDL/0037/POOD/10		
Współpraca:			
mgr inż. Paweł Makac			

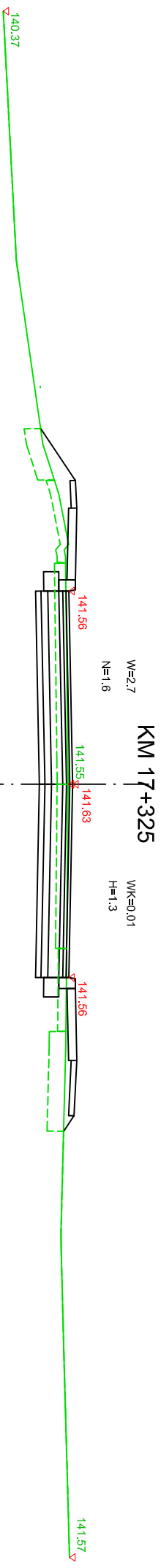
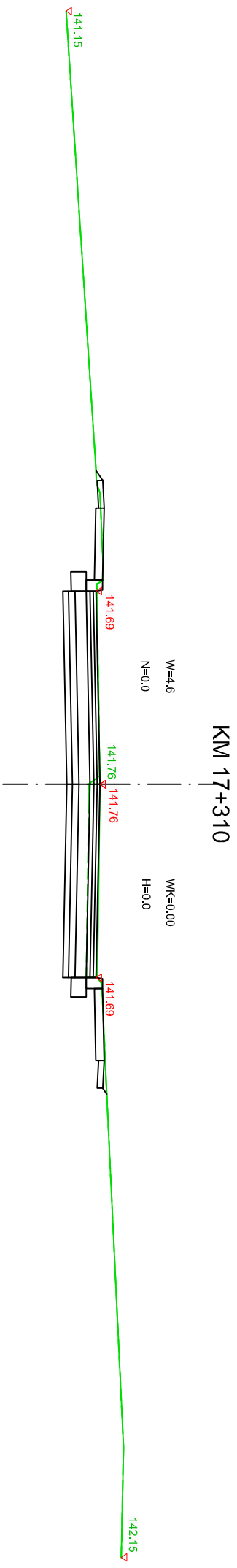

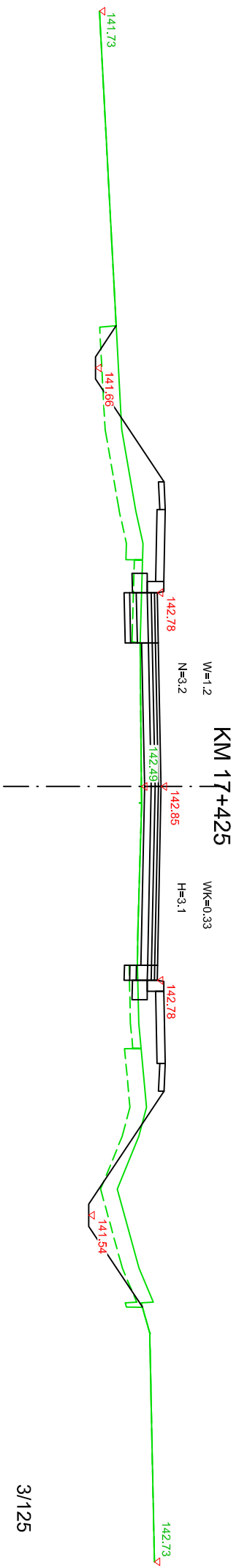
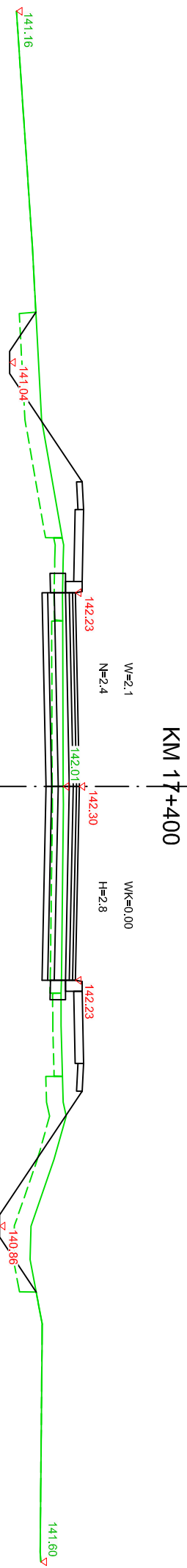
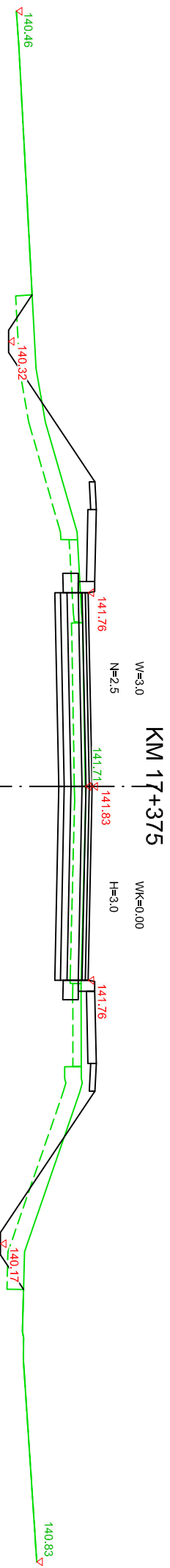

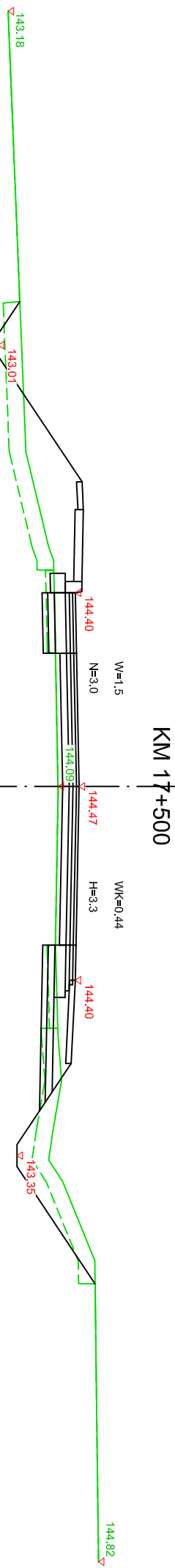
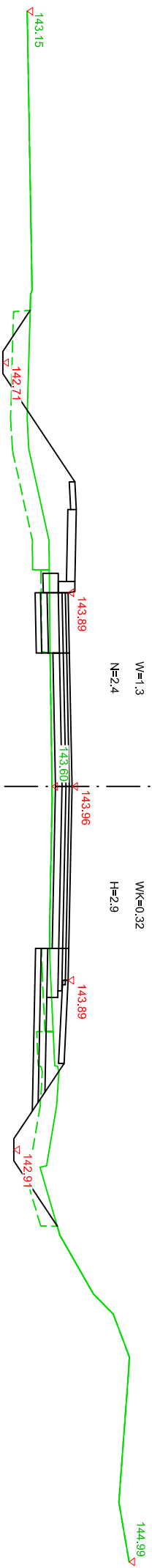
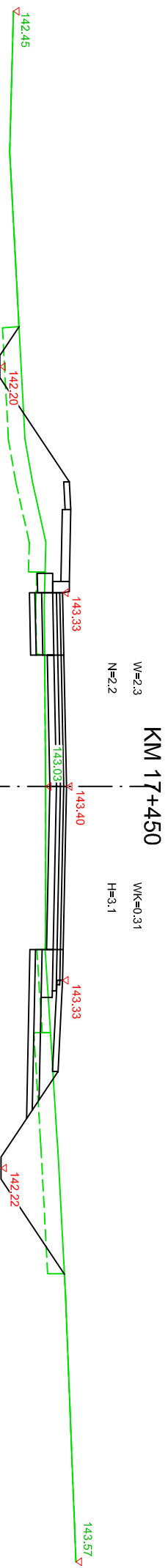

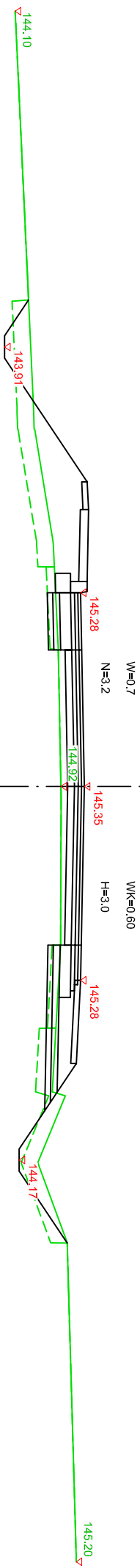
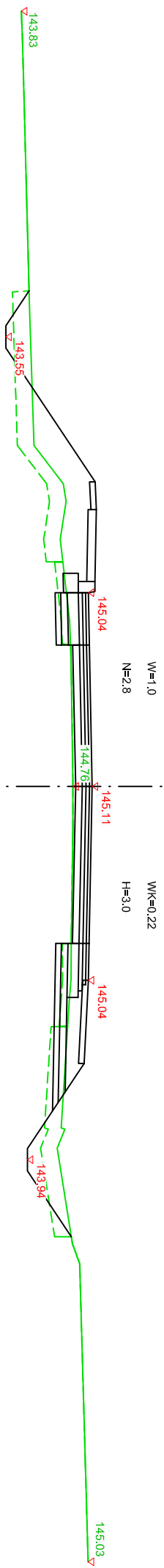
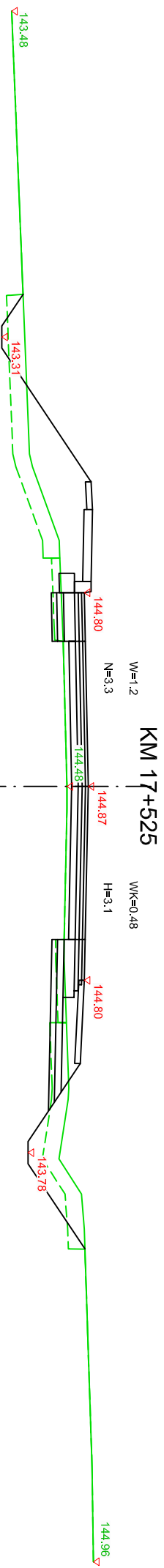

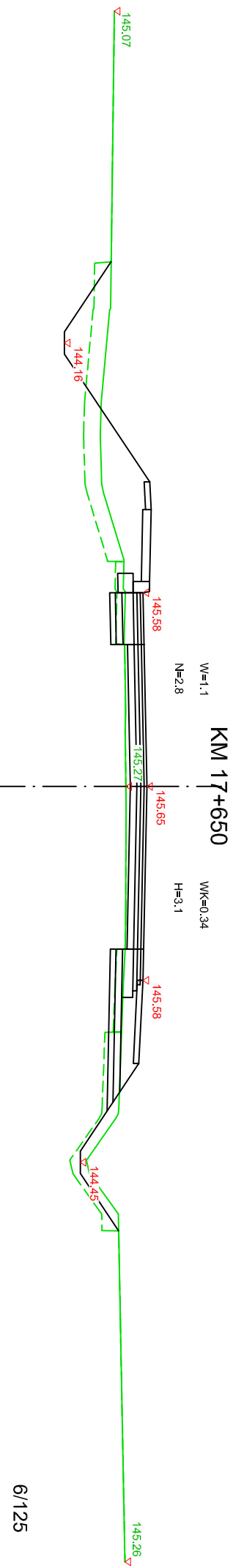
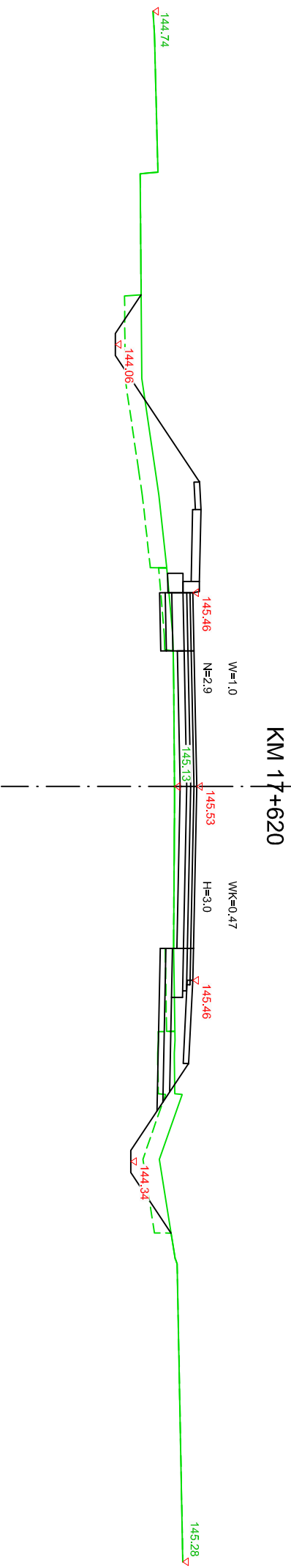
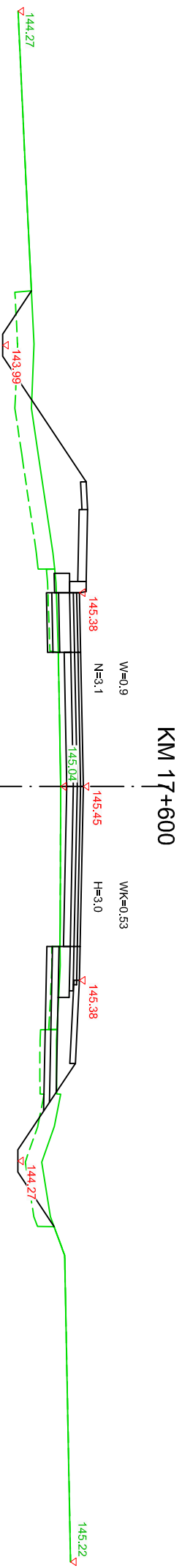

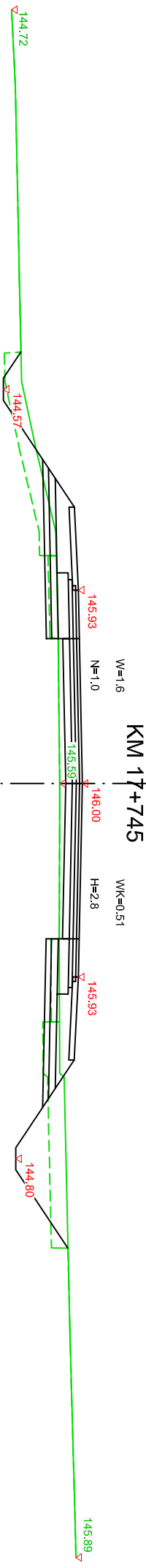
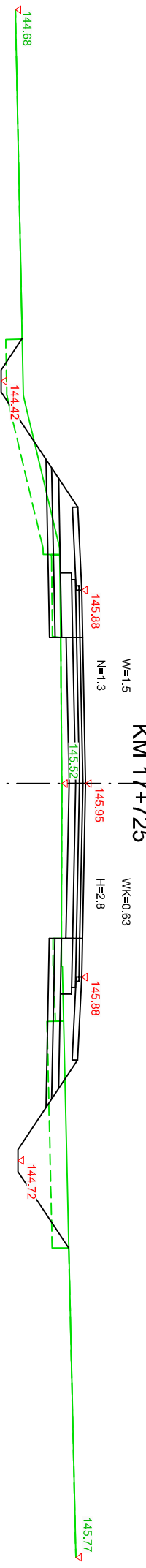
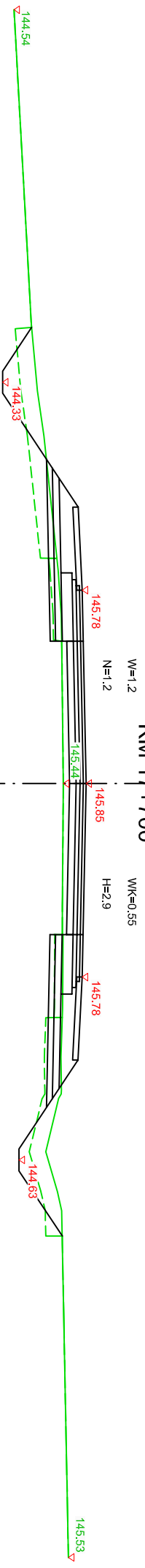
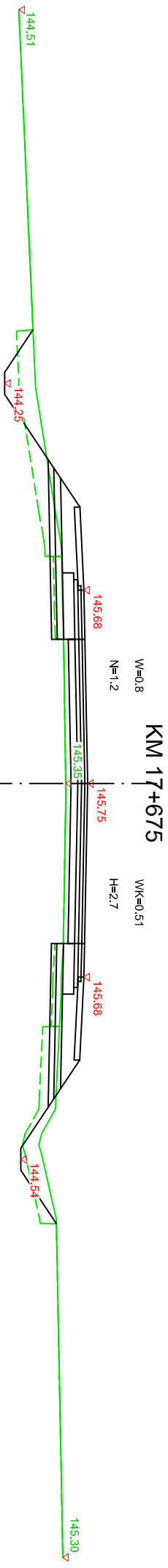

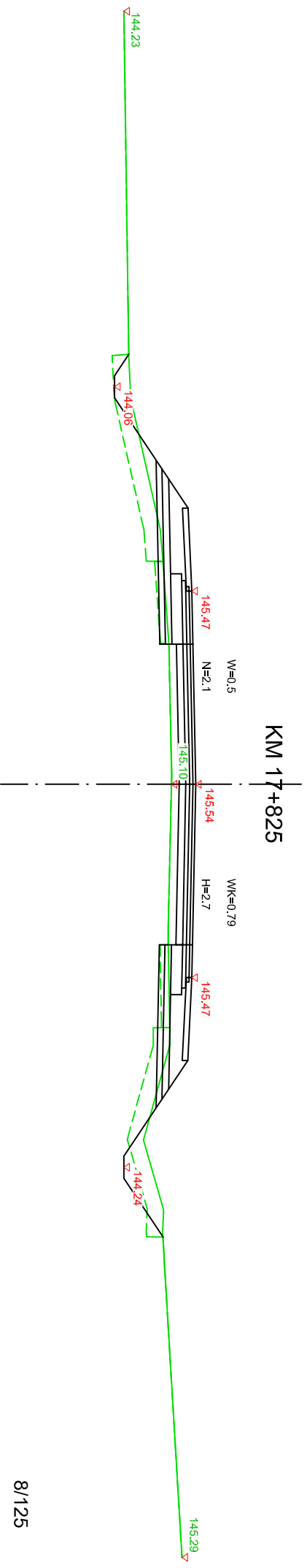
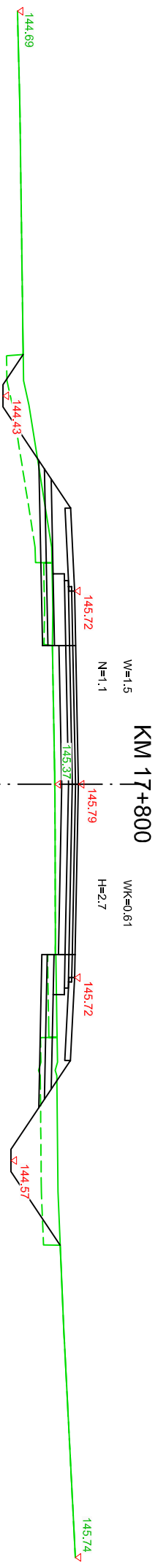
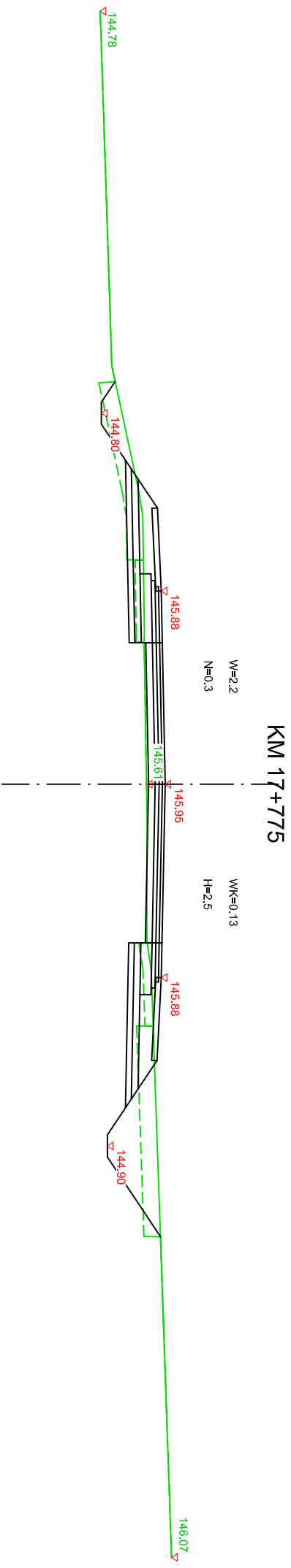



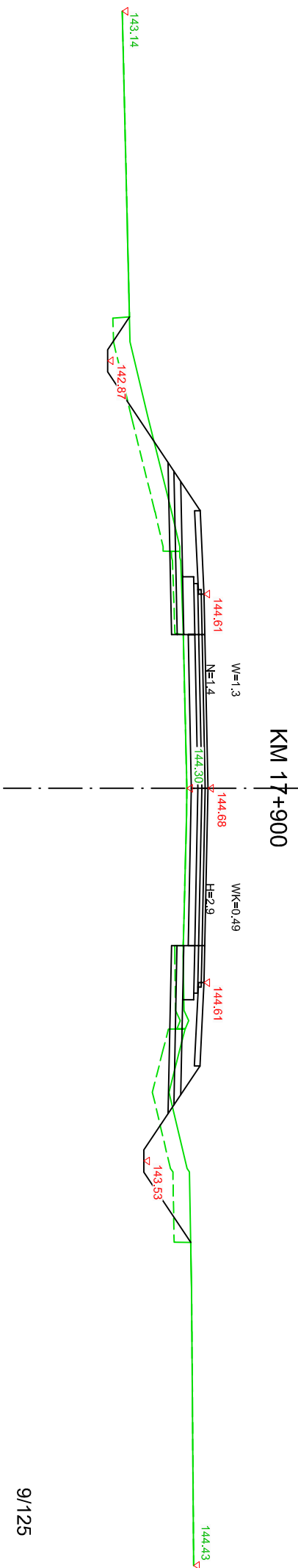
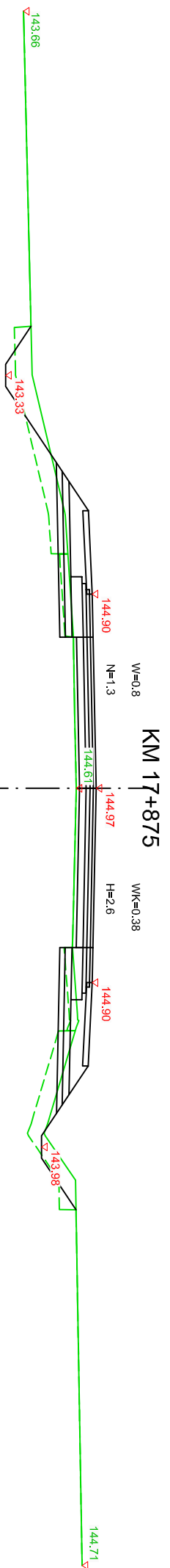
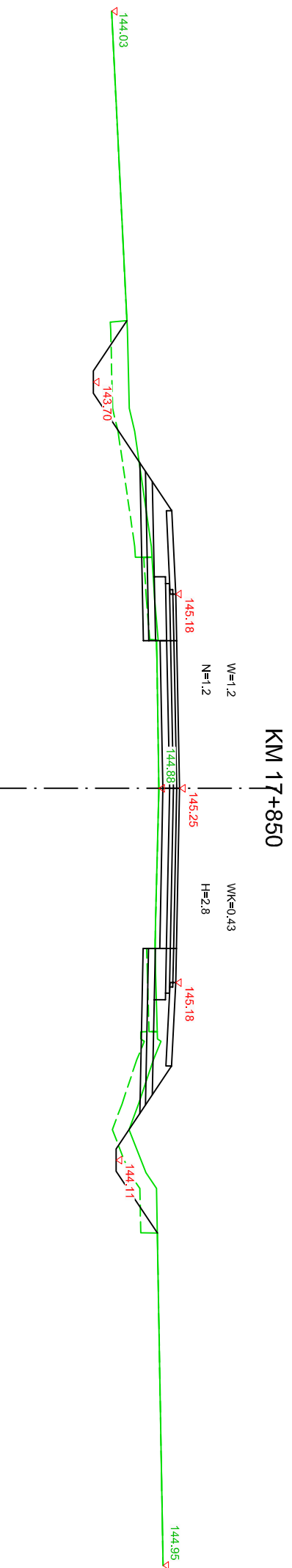

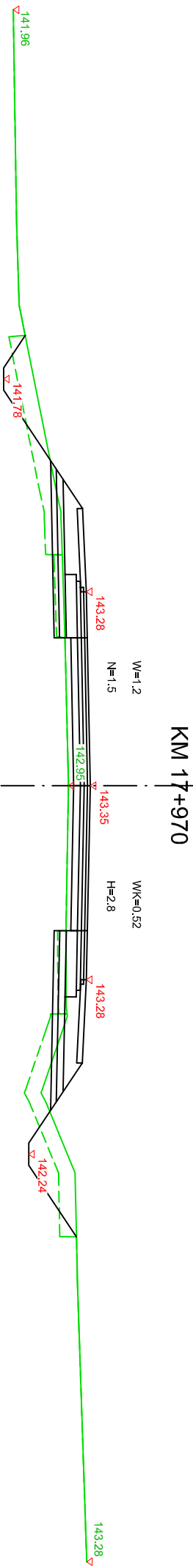
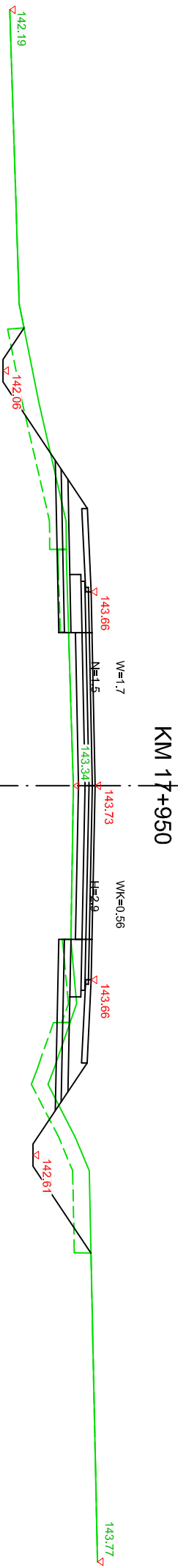
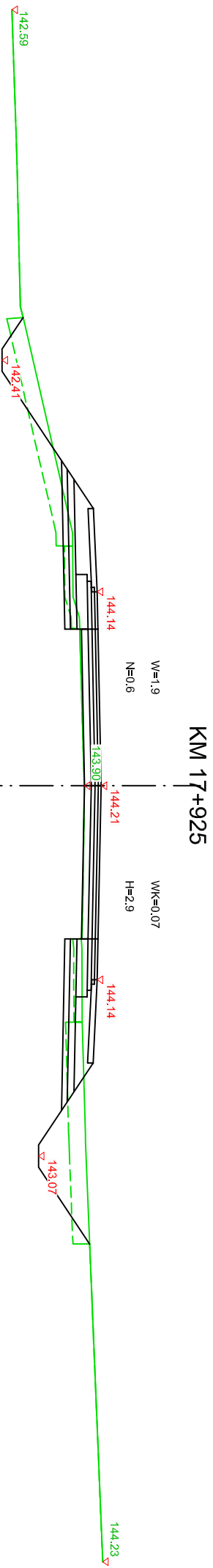

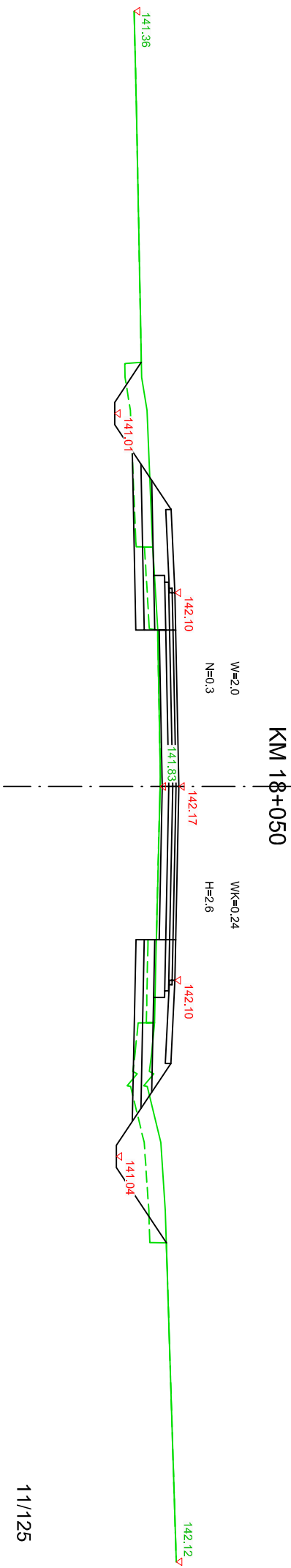
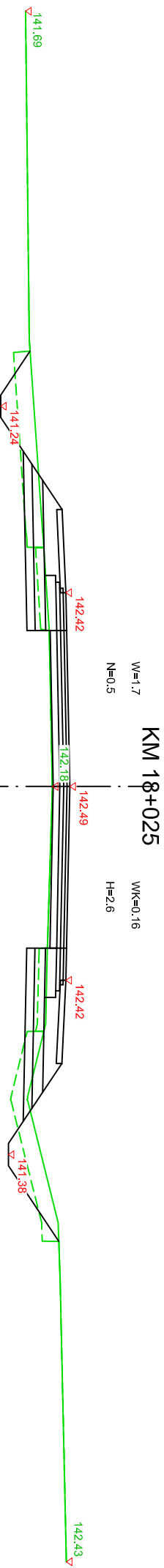
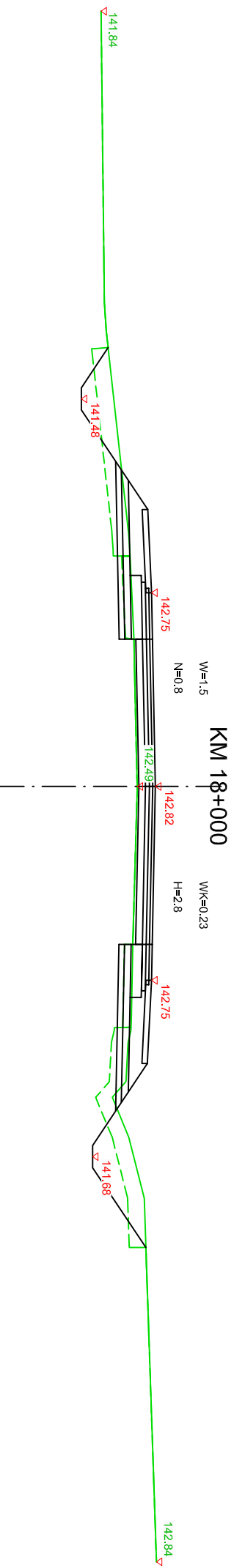

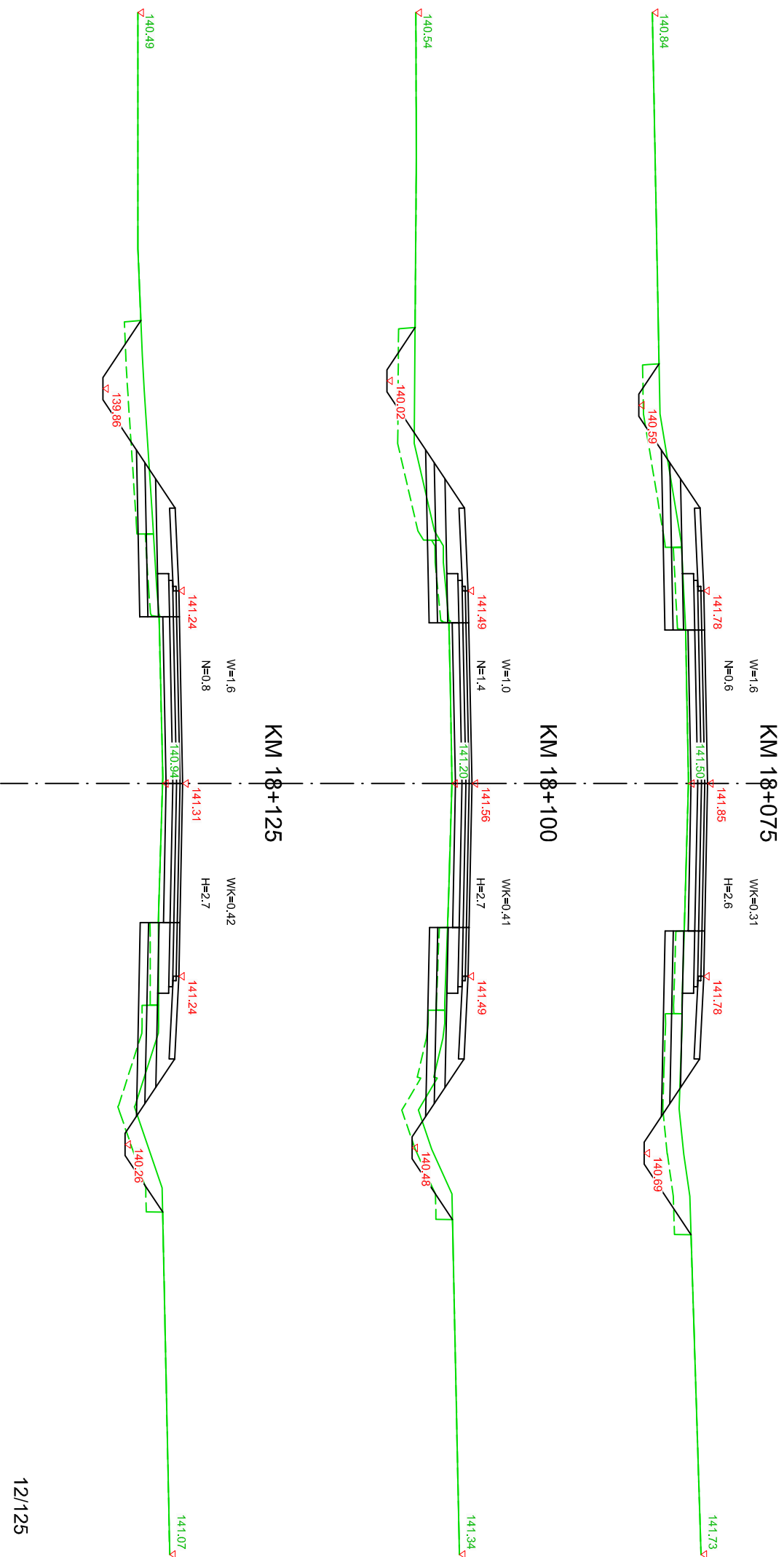

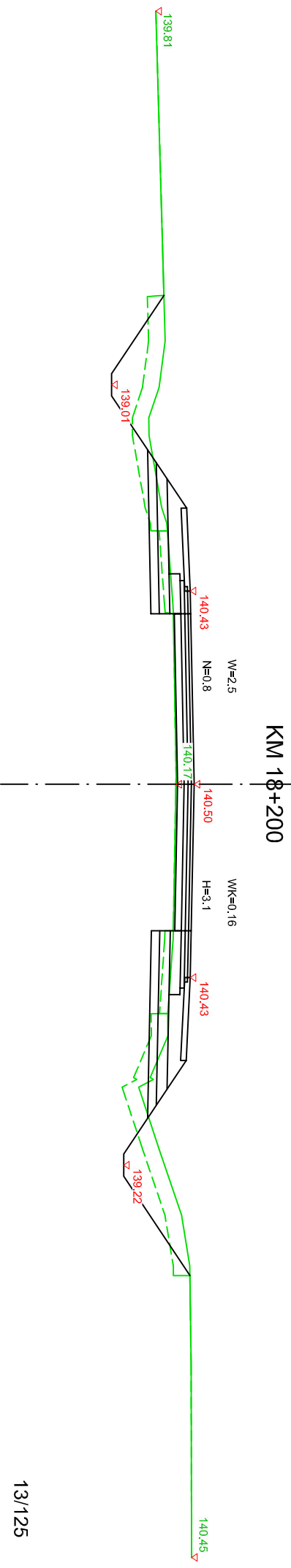
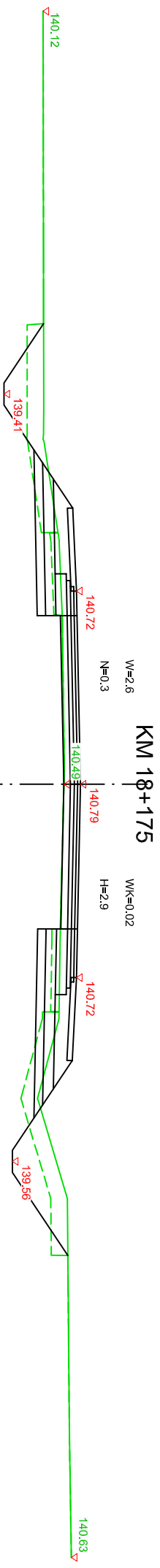
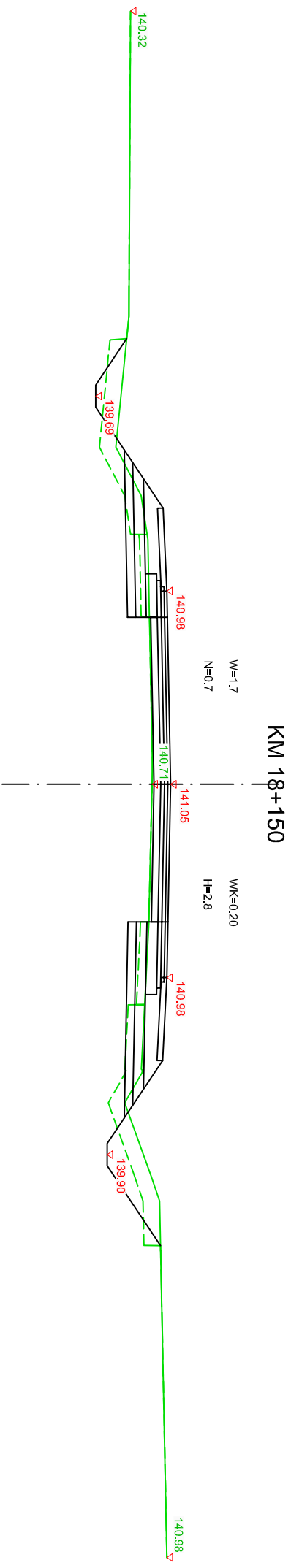

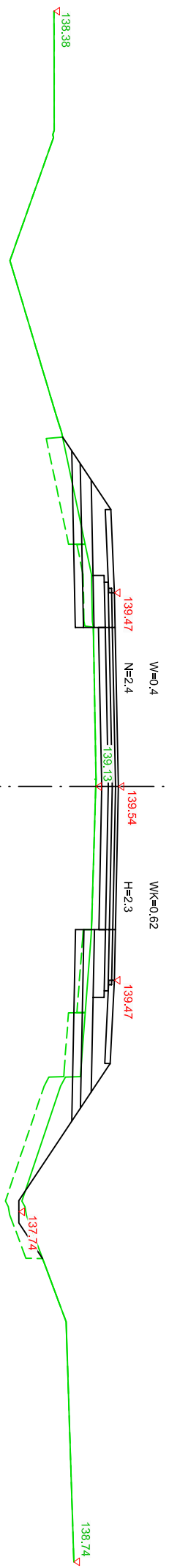
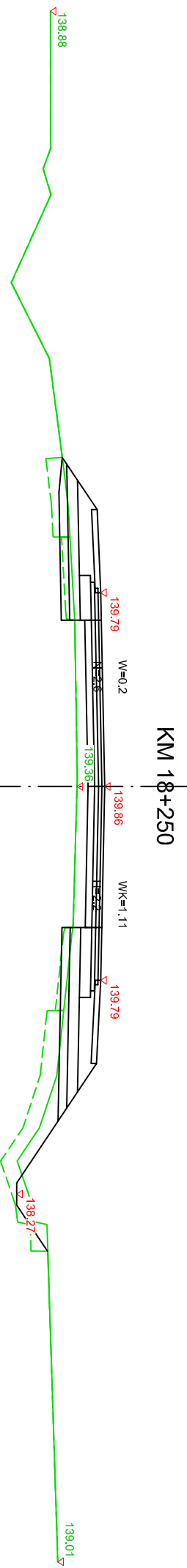
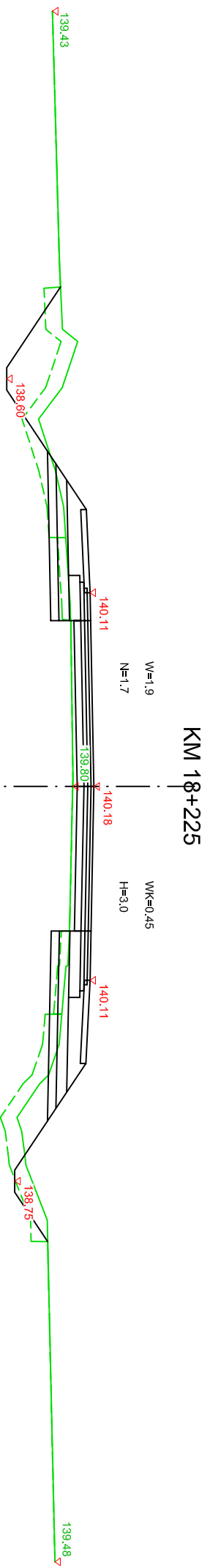

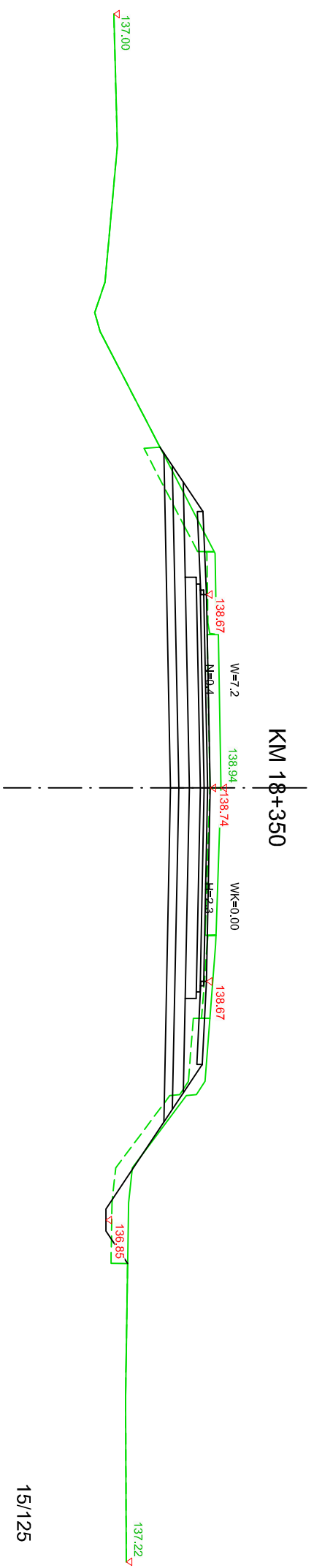
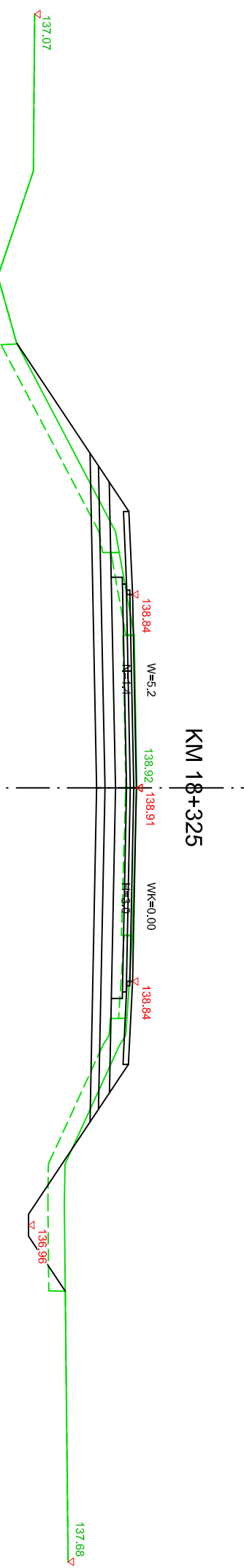
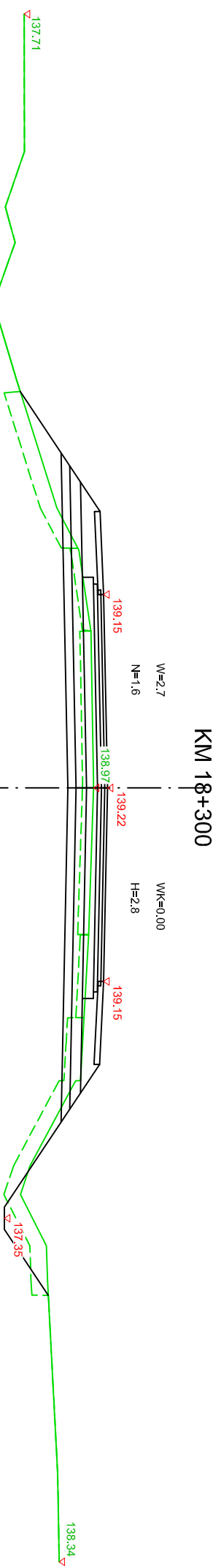

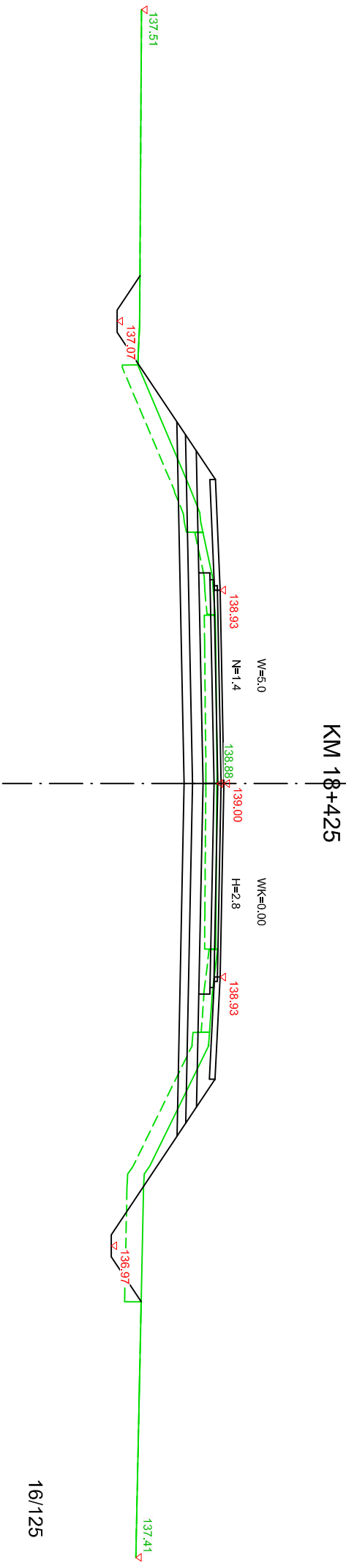
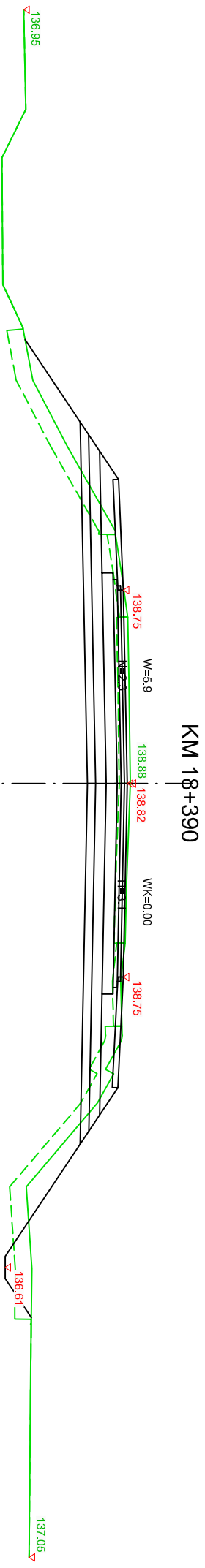
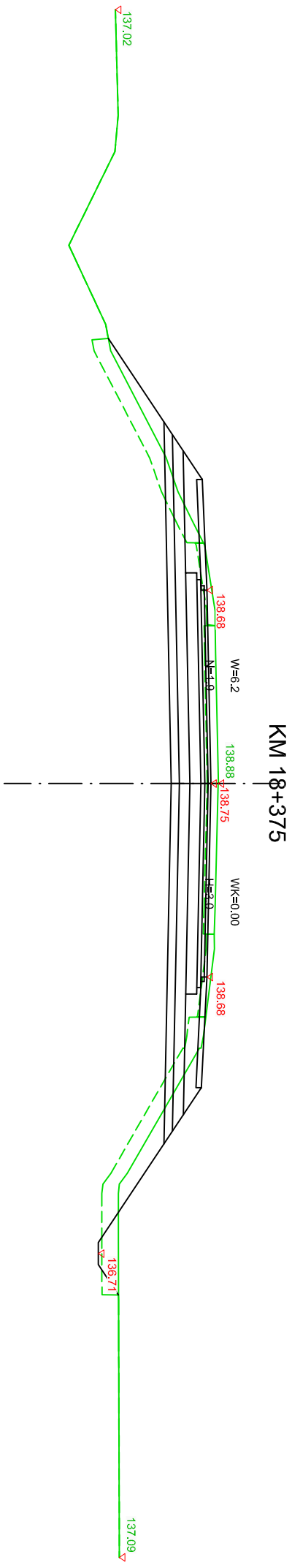



### KM 18+450

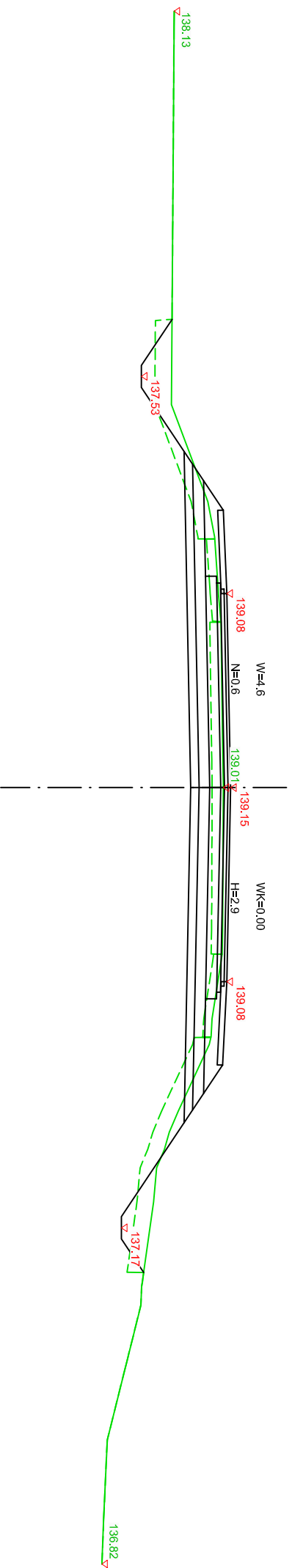

### KM 18+475

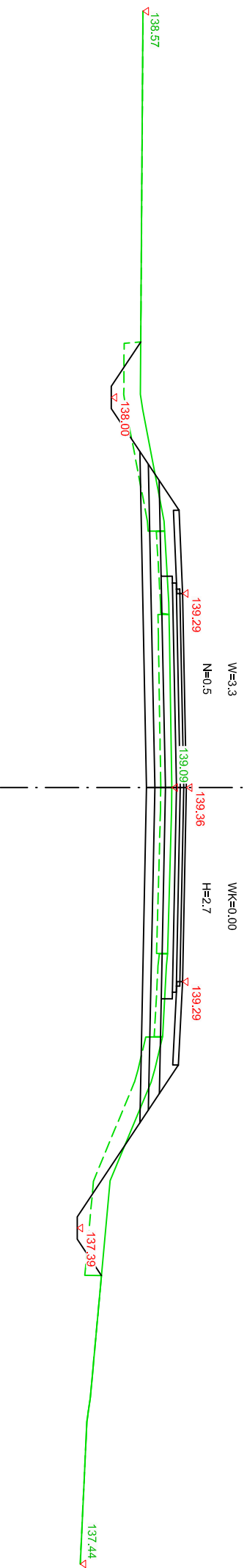

### KM 18+500

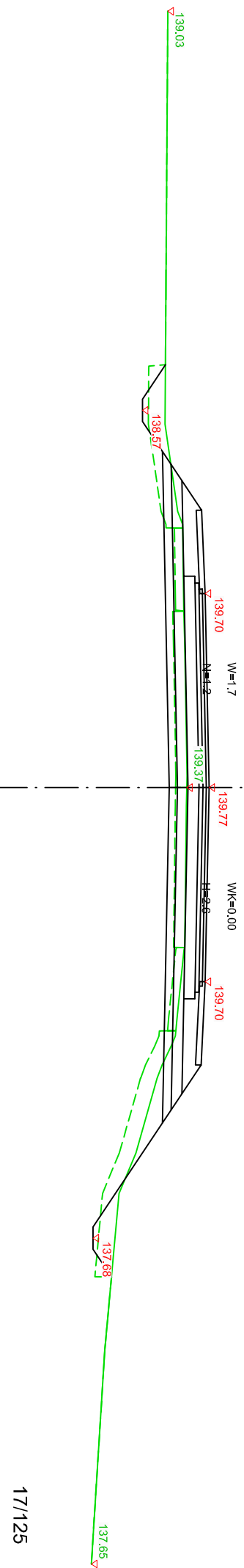

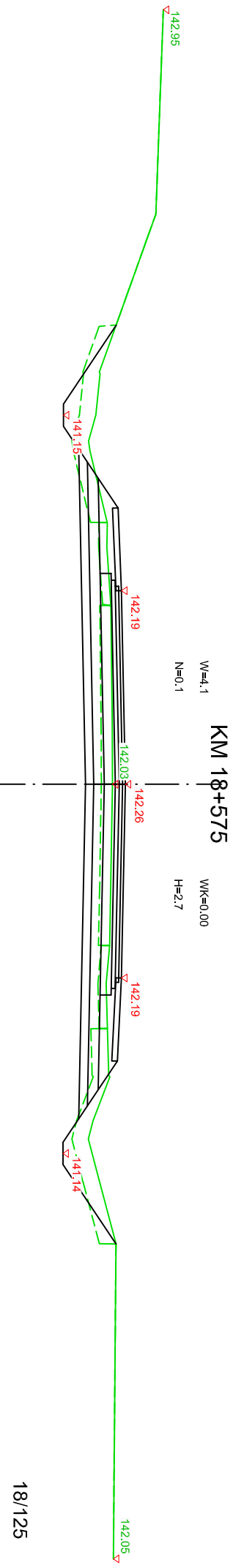
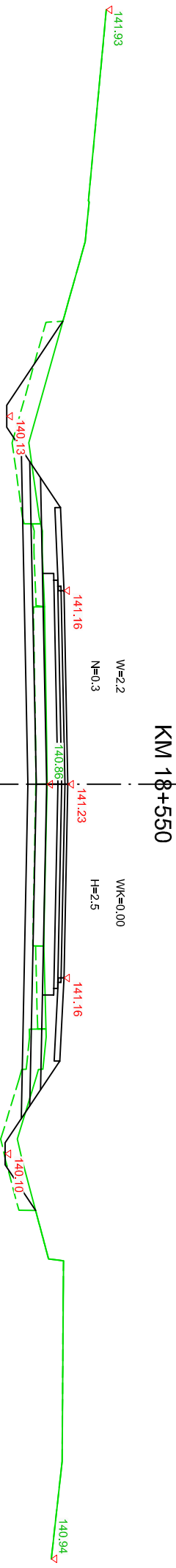
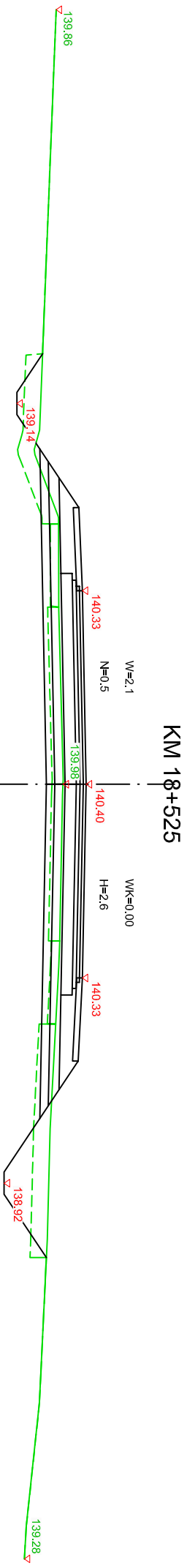

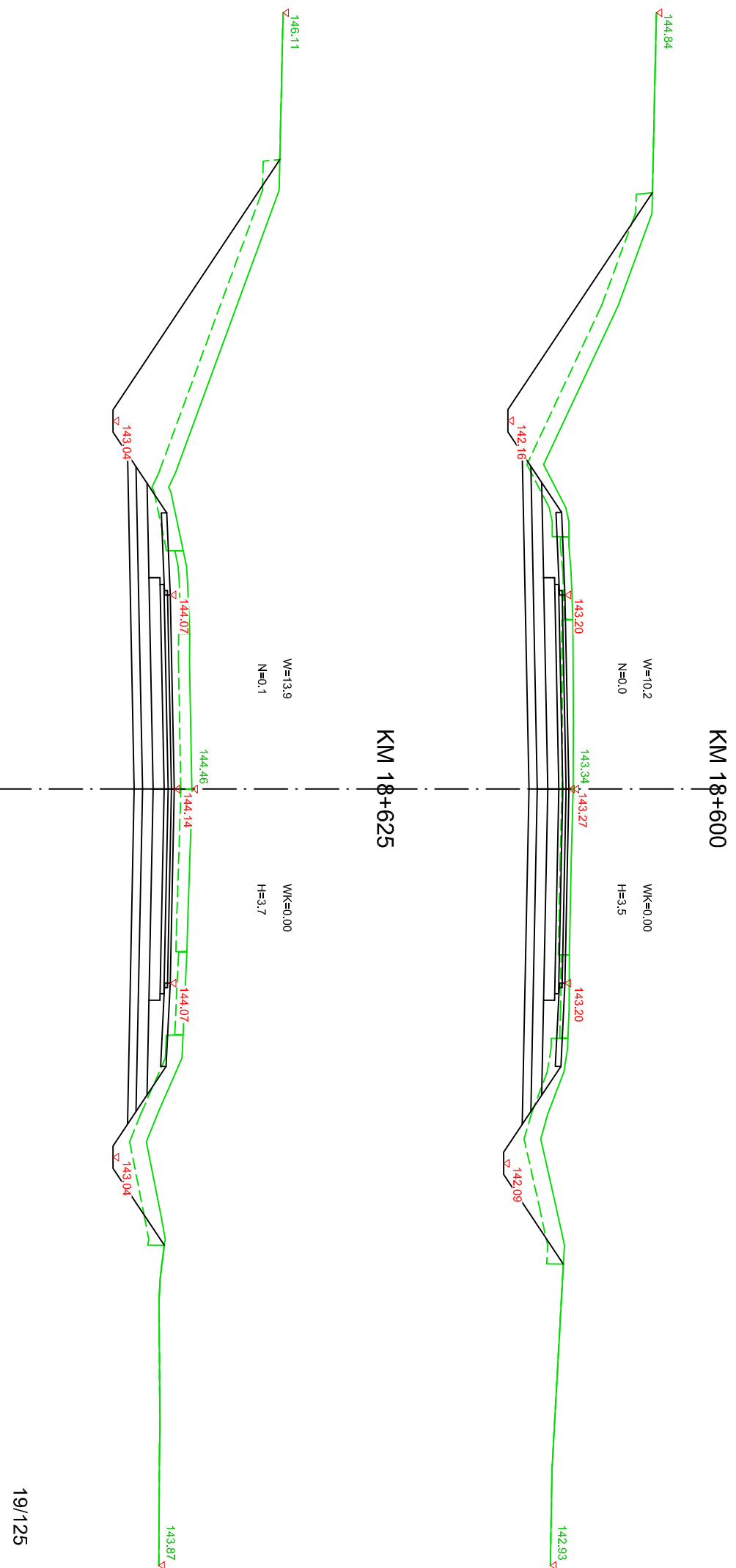

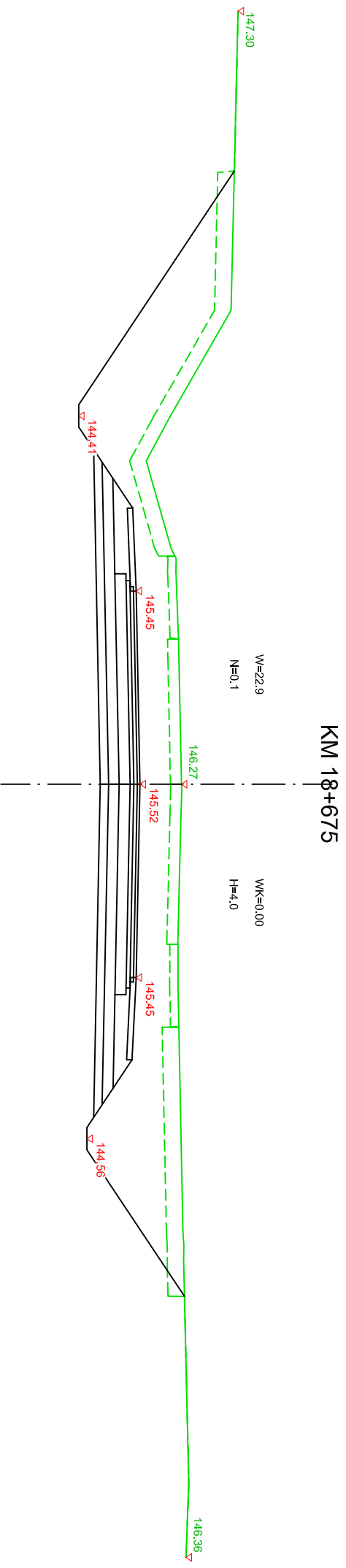
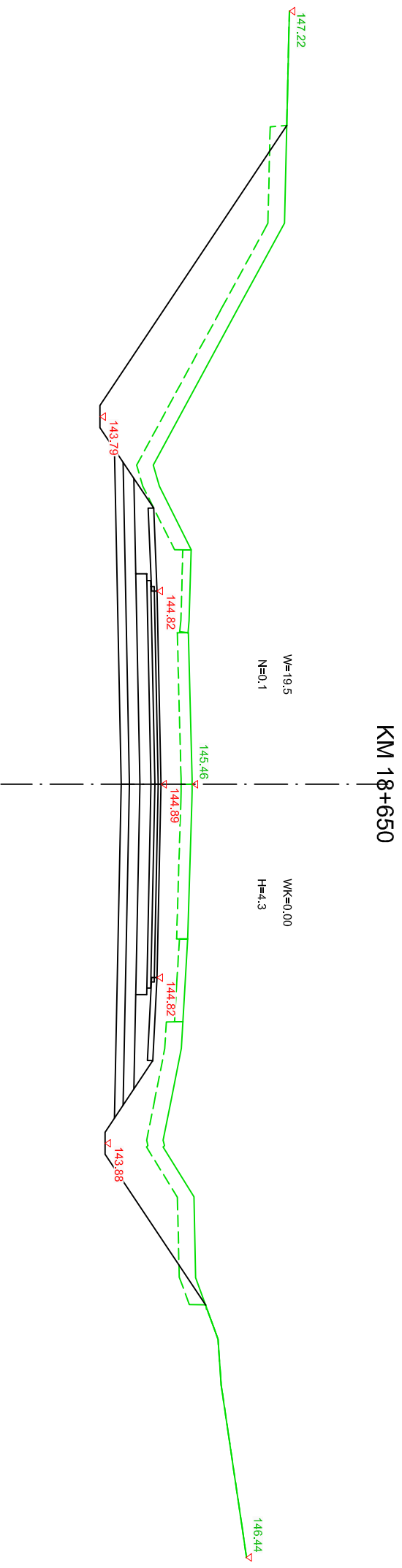

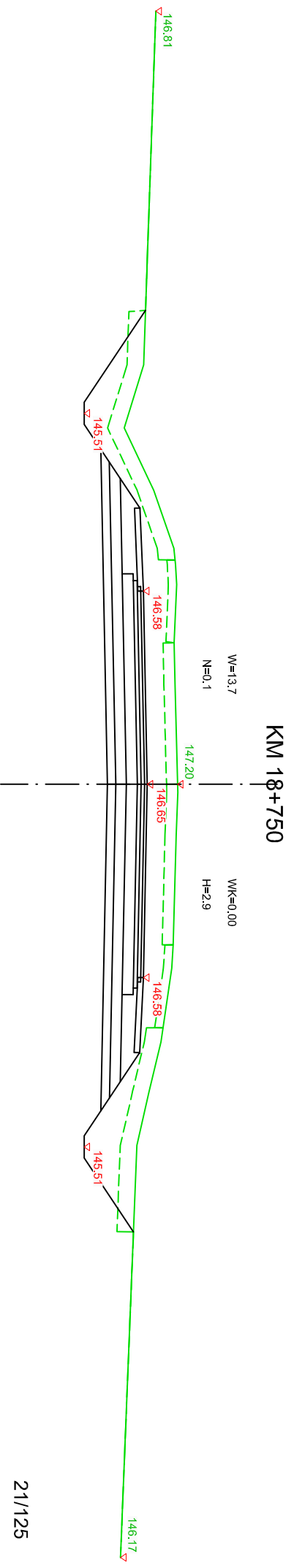
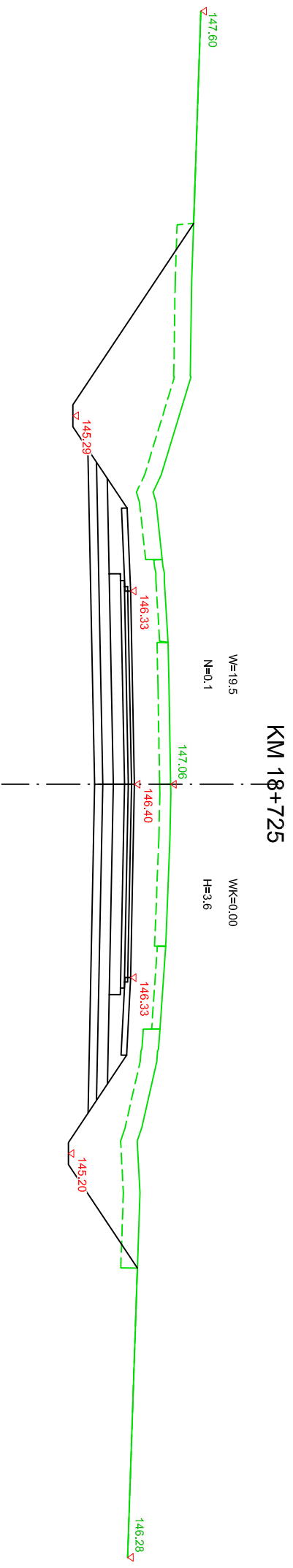
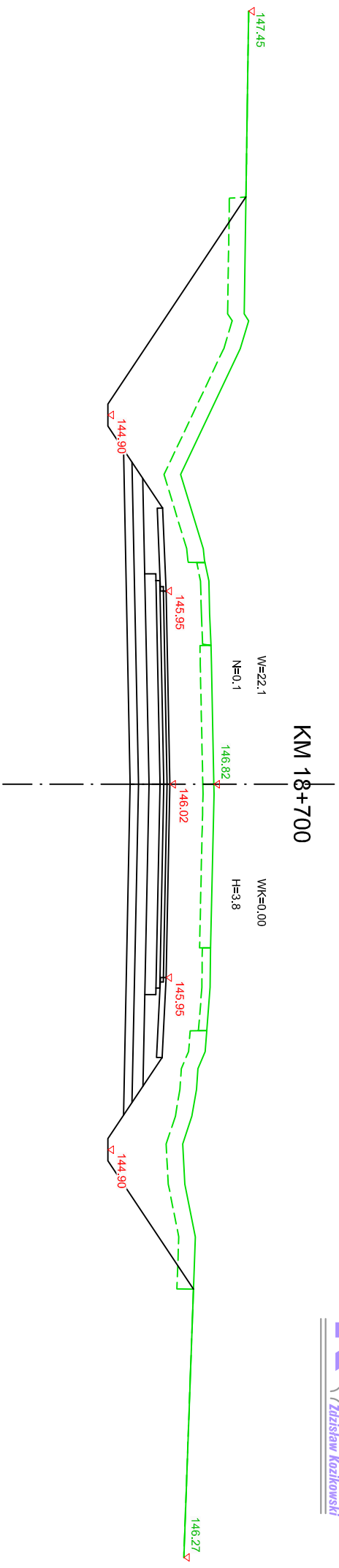

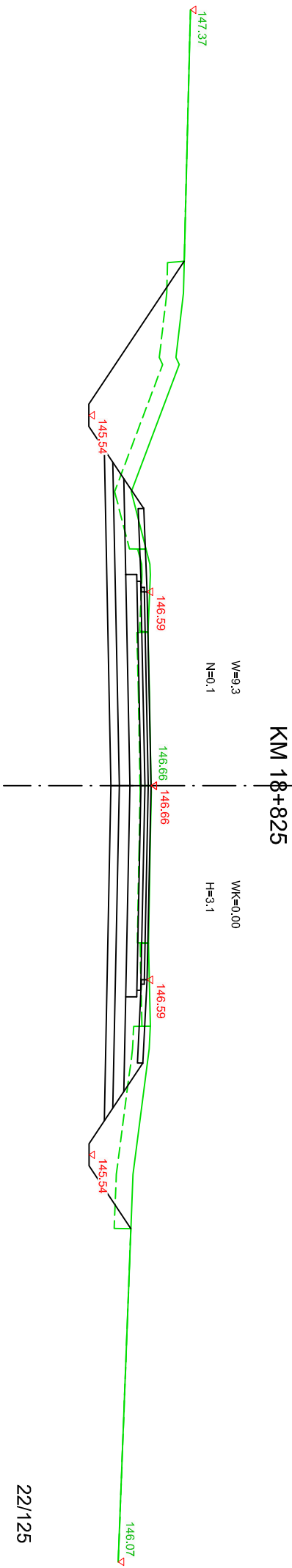
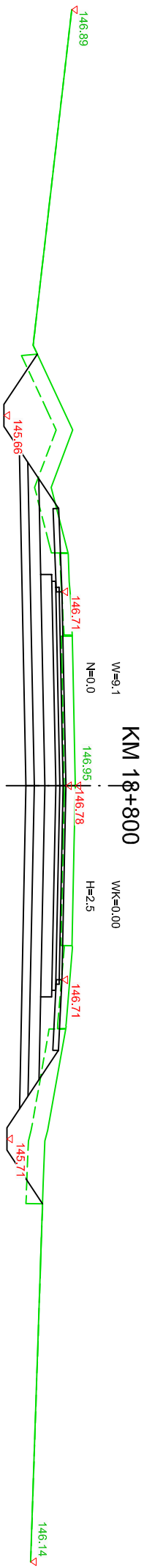
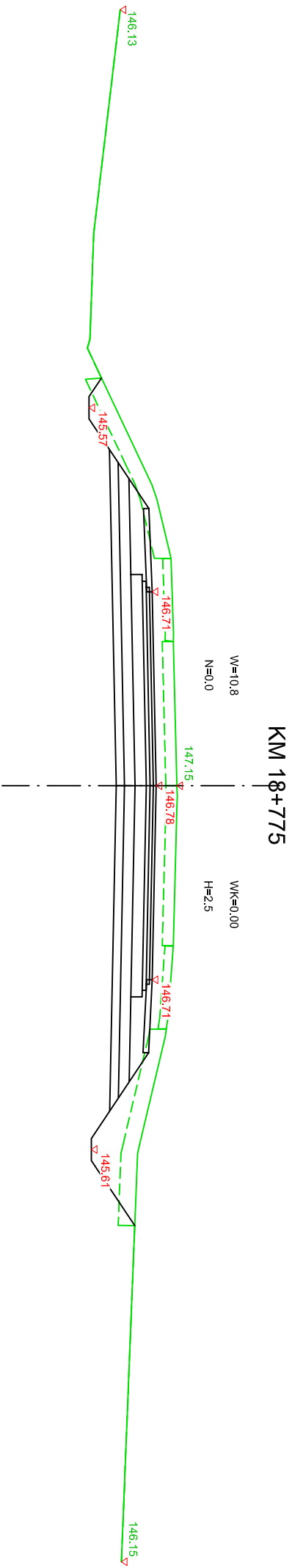

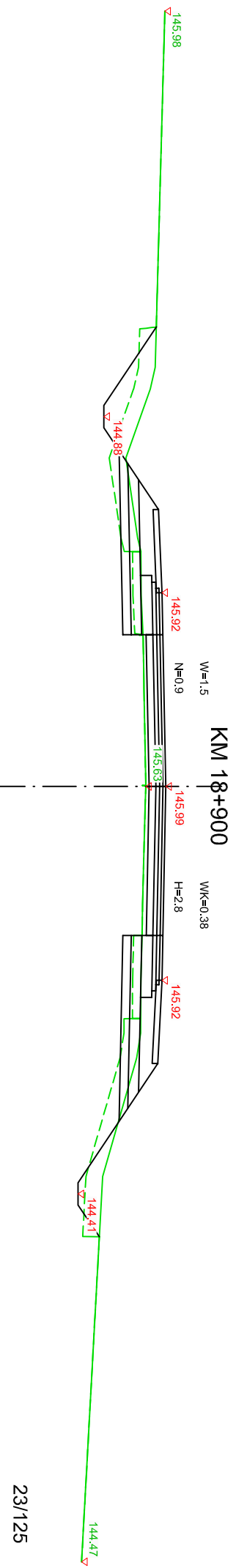
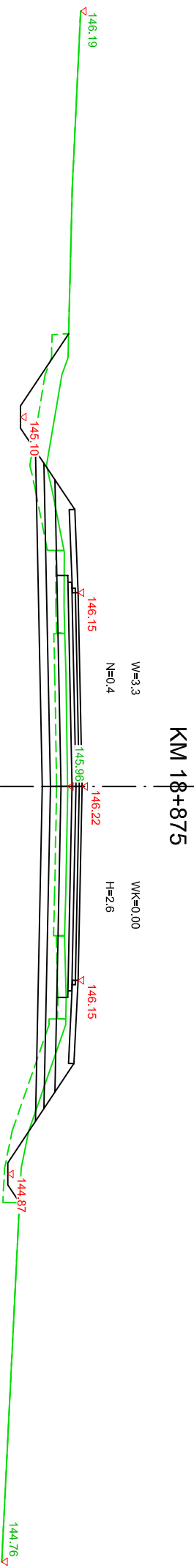
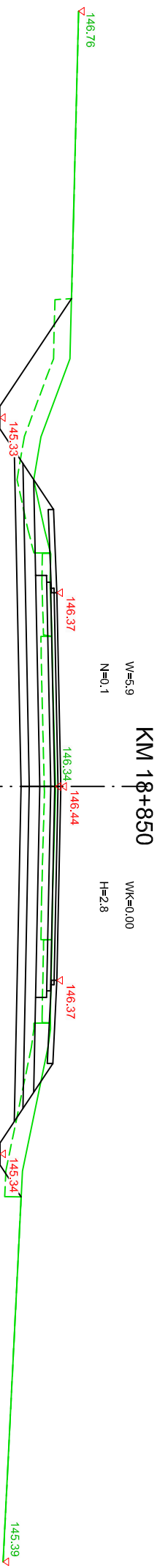

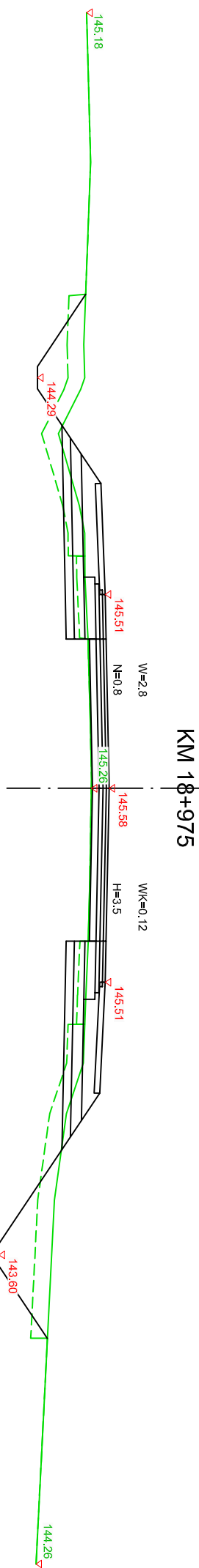
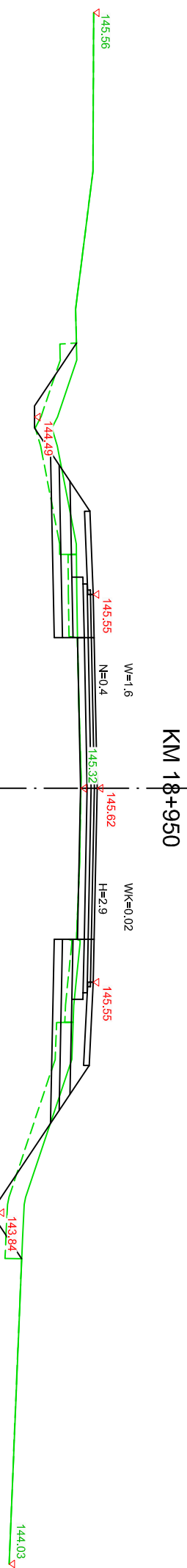
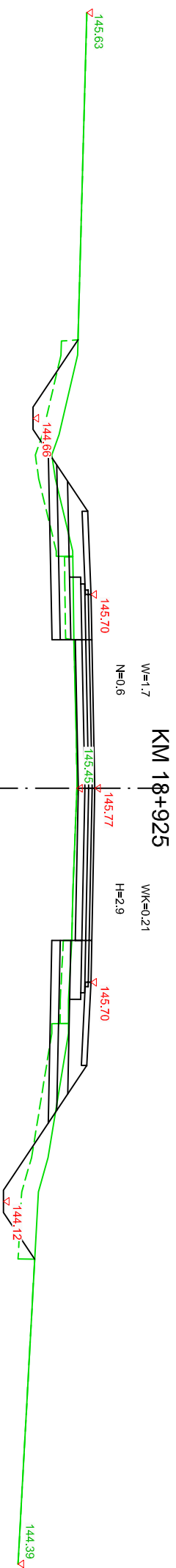



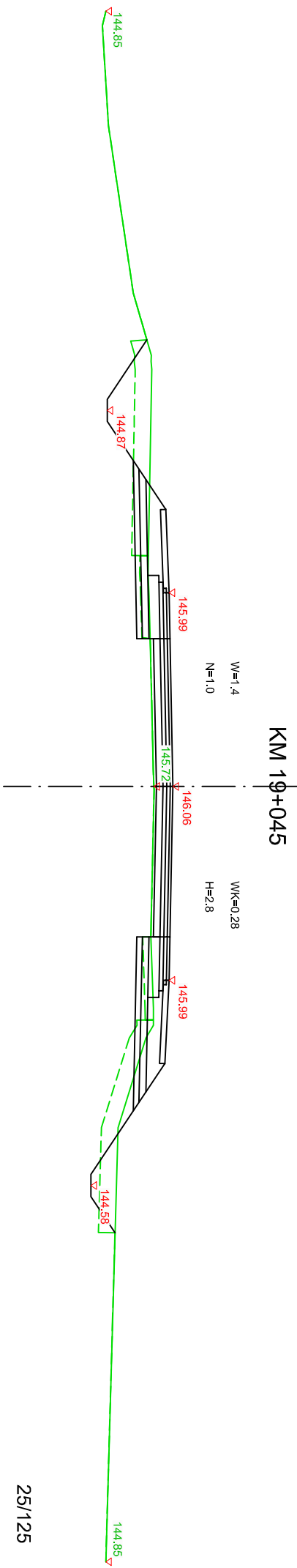
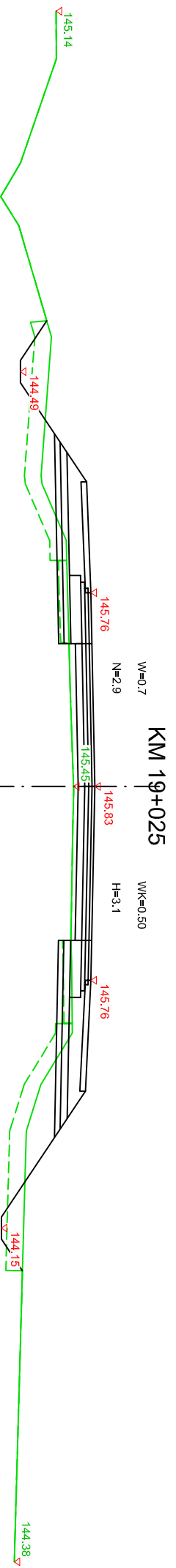
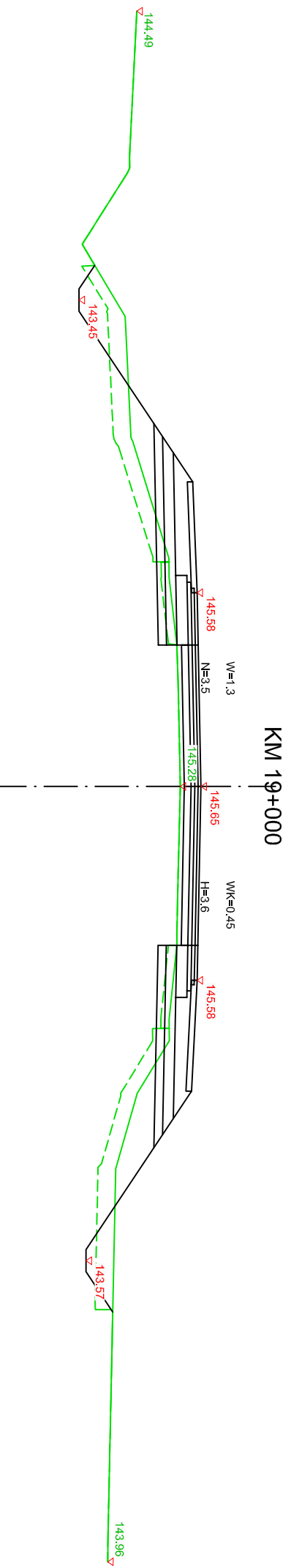

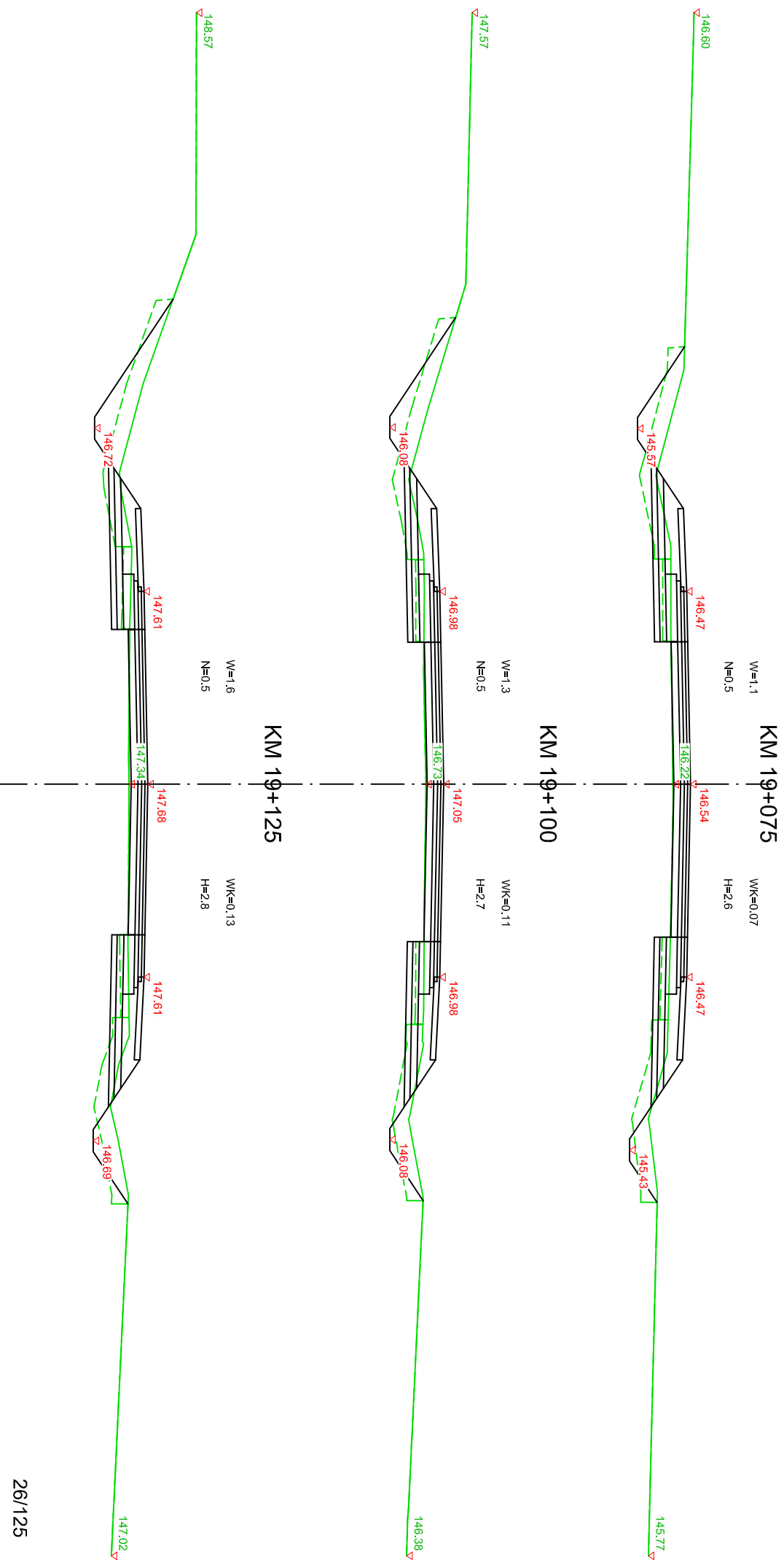

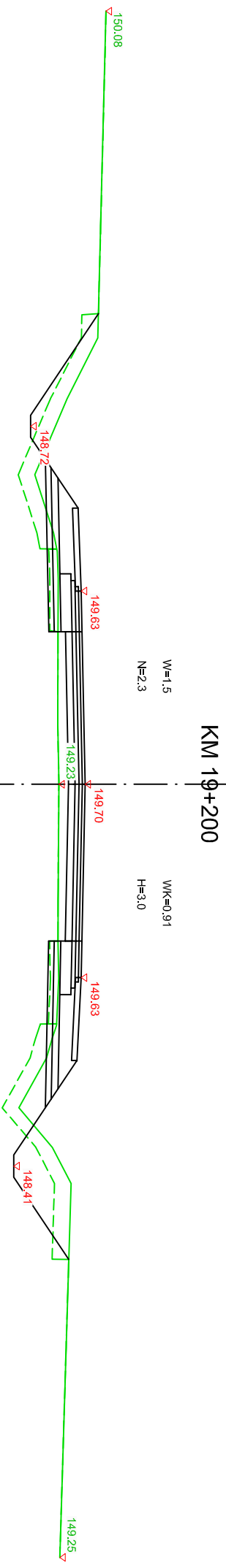
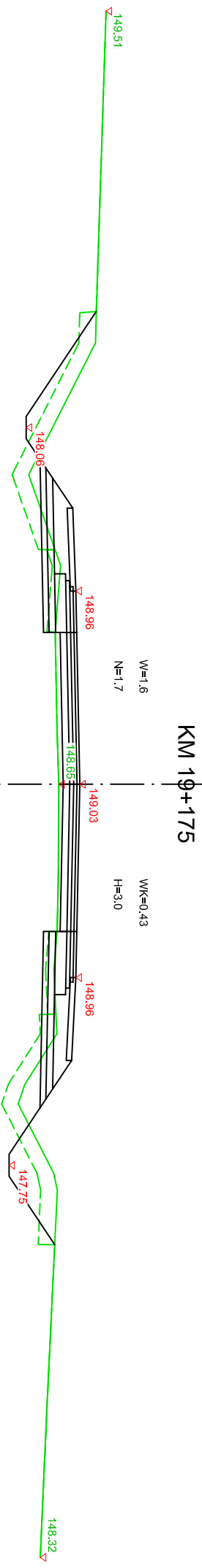
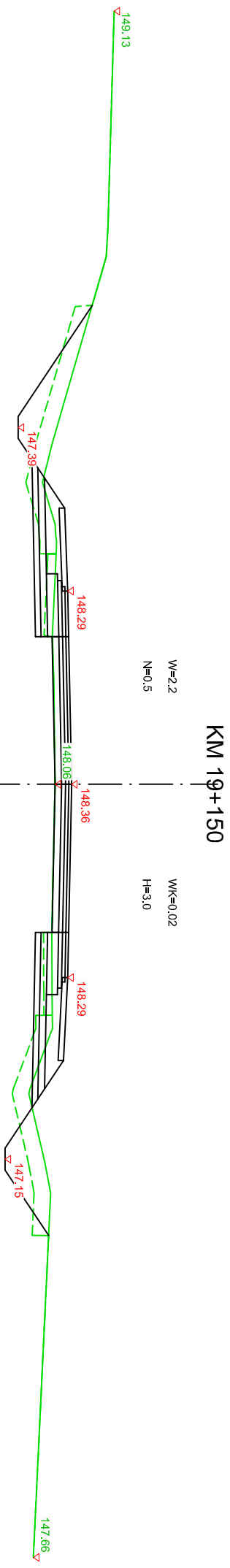

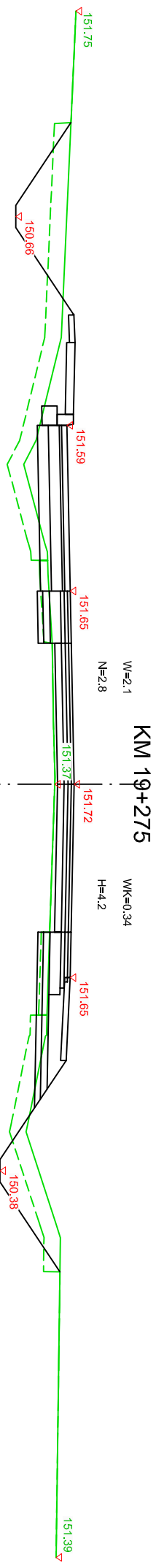
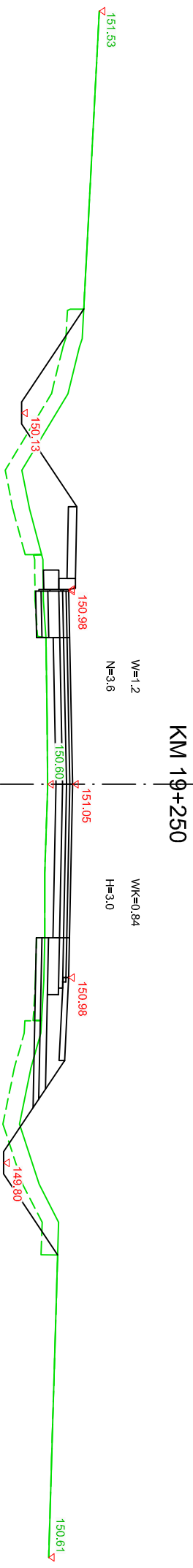
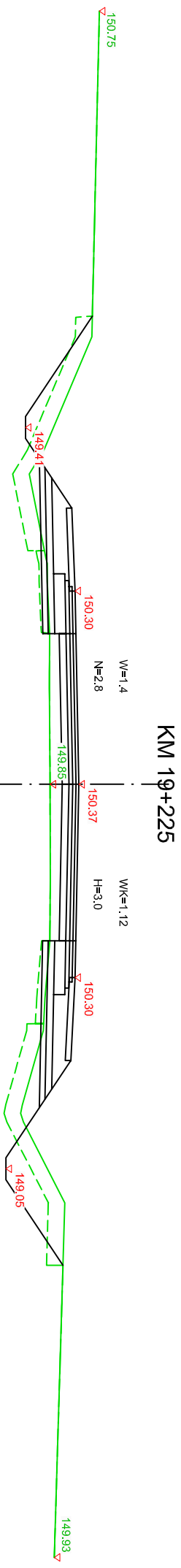

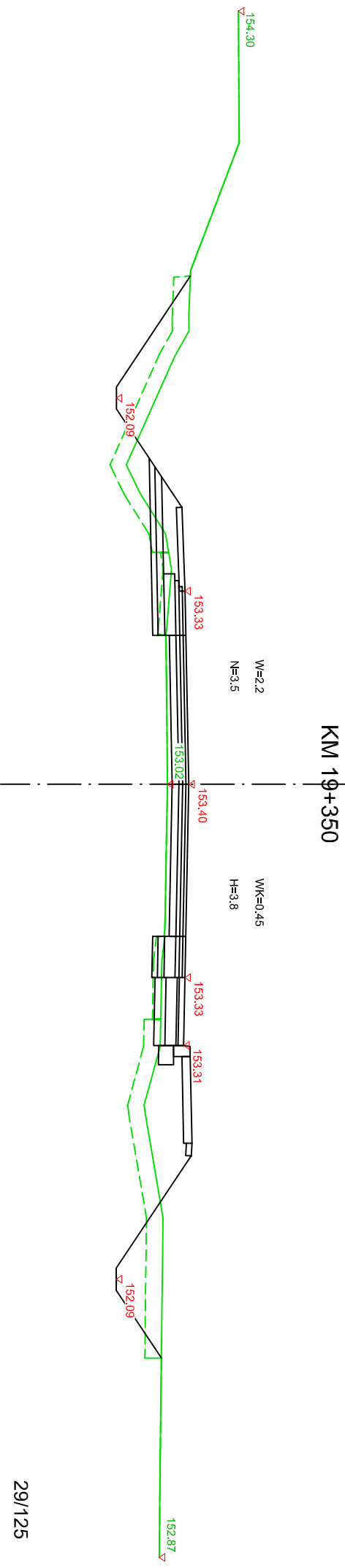
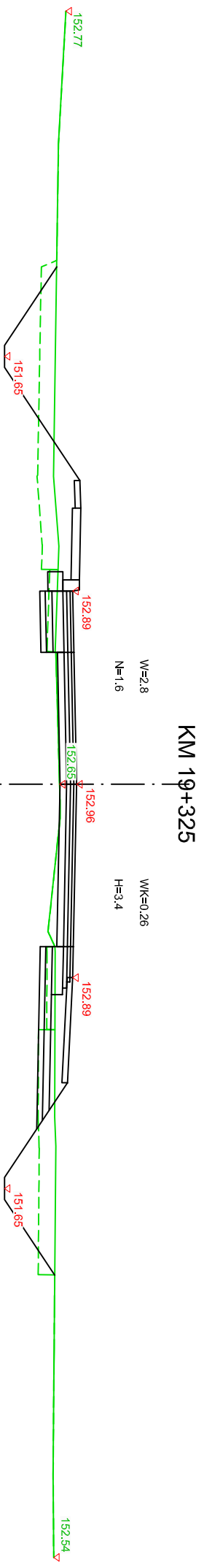
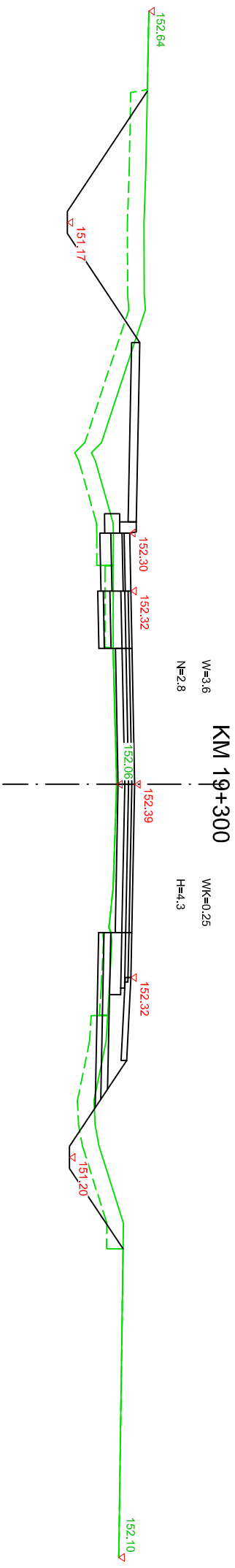

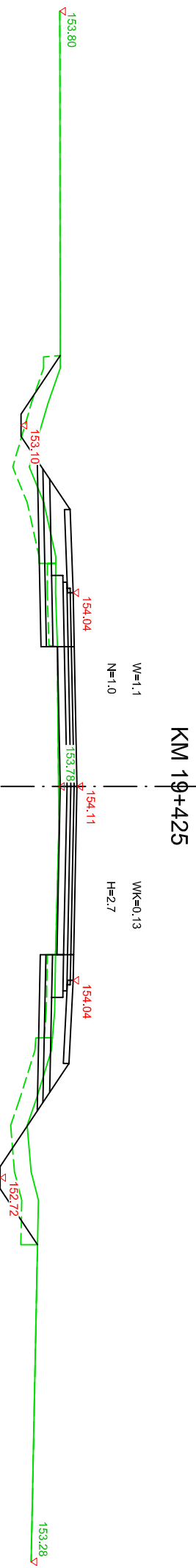
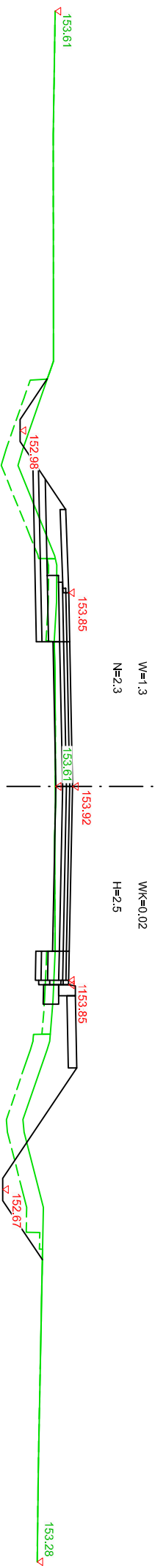
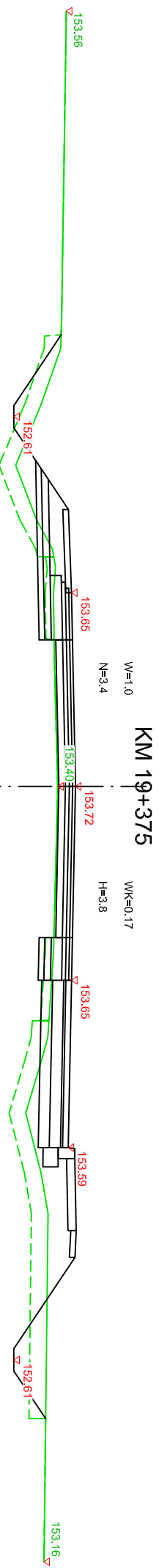

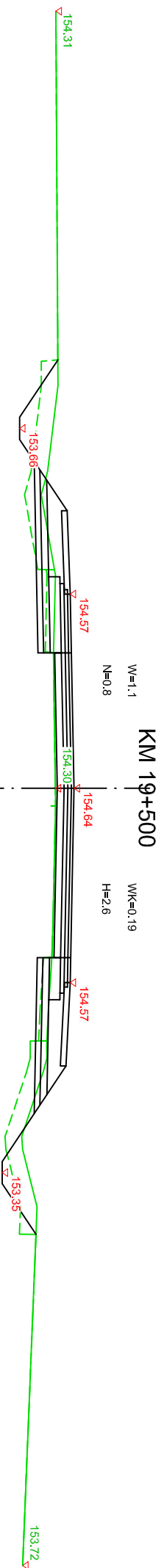
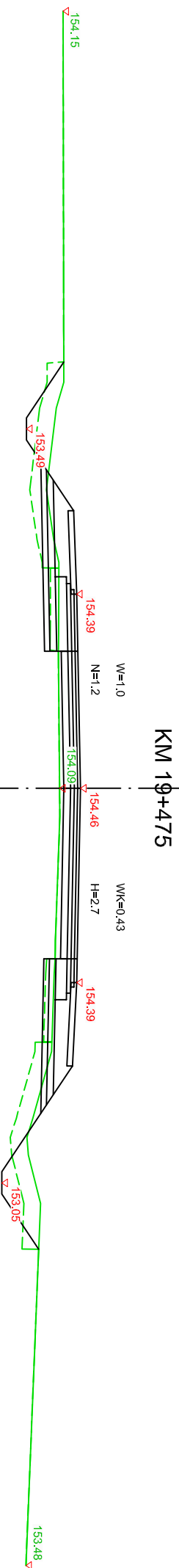
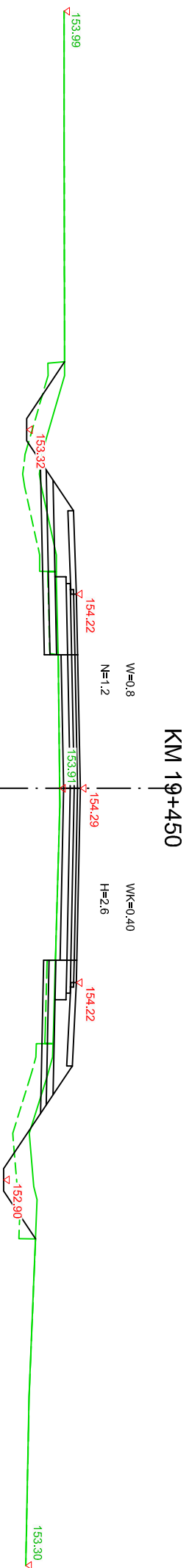

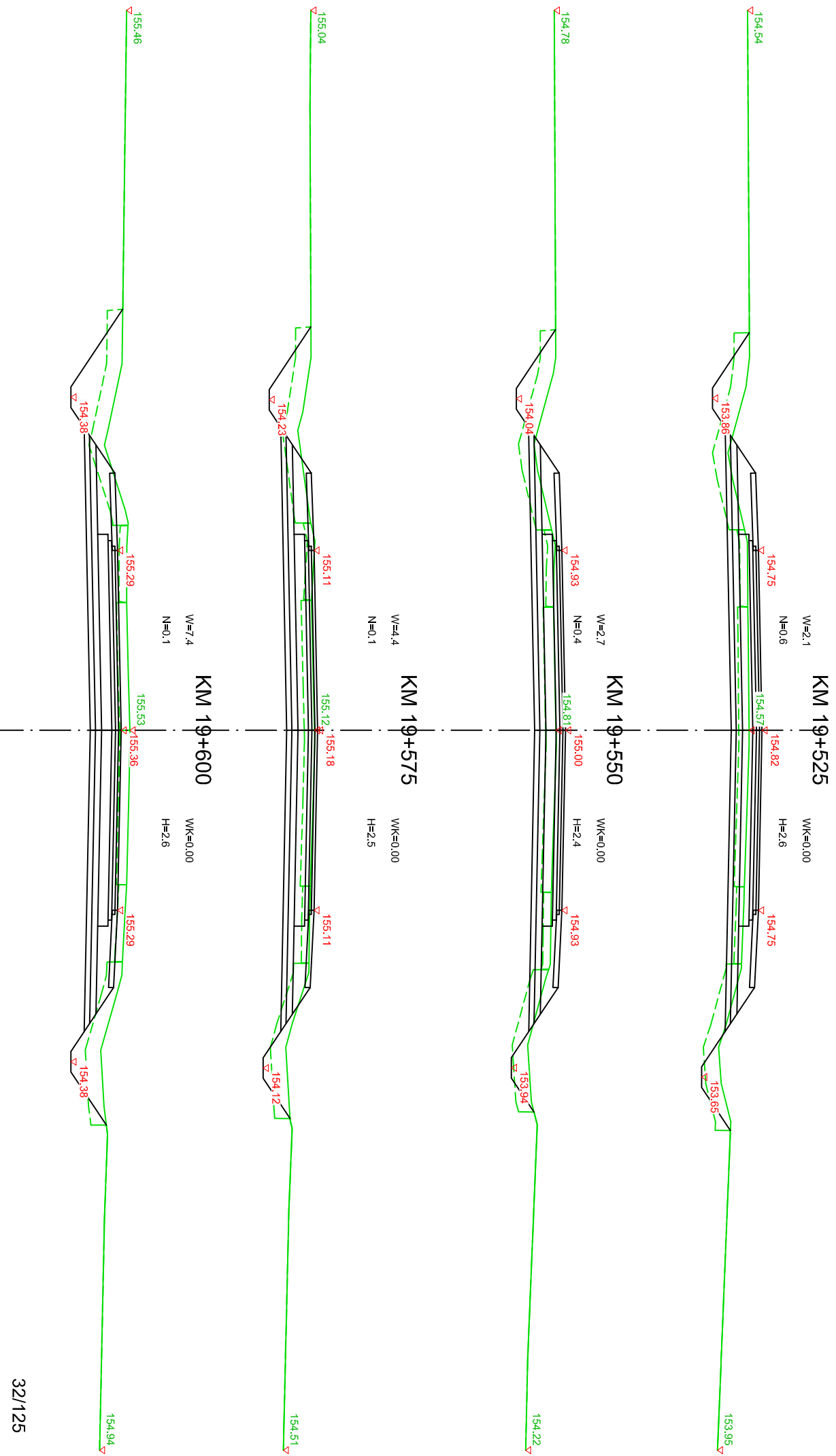



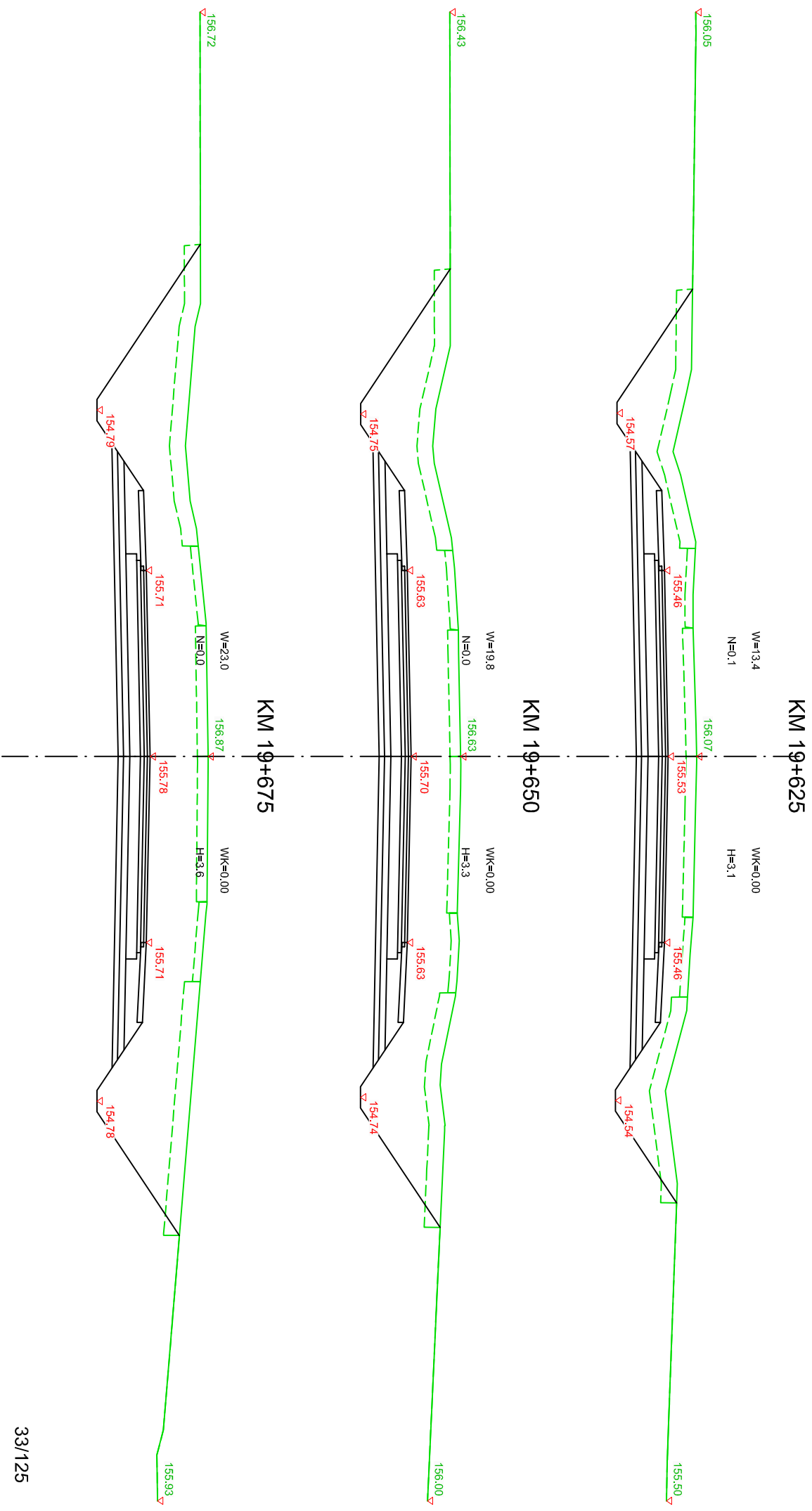

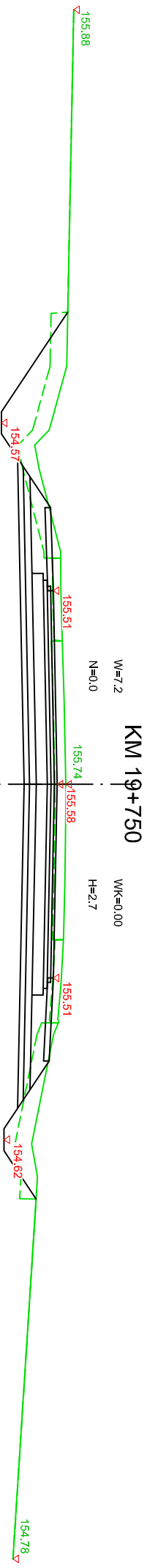
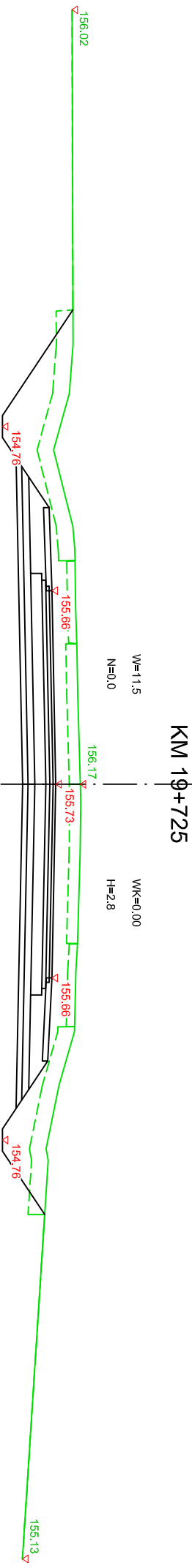
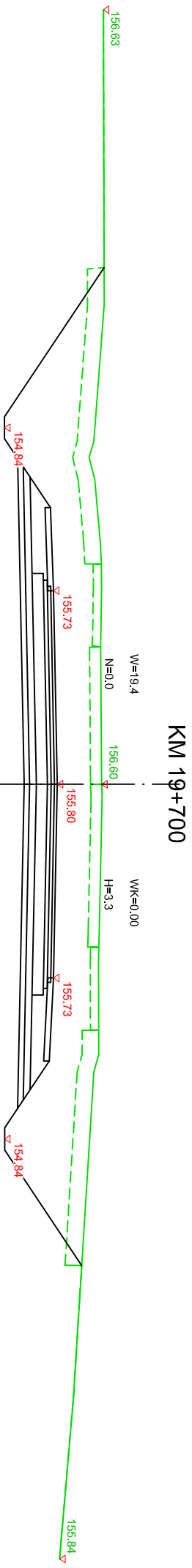

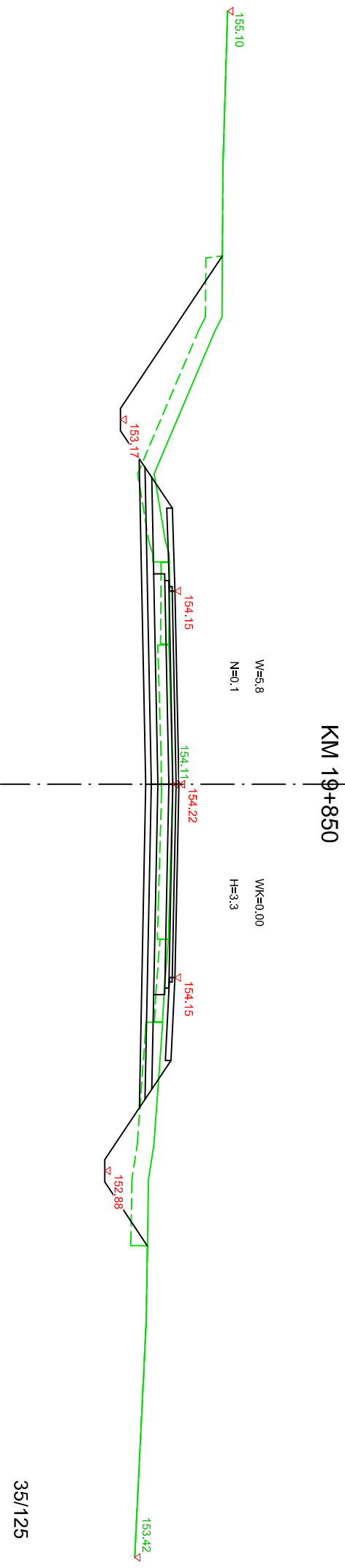
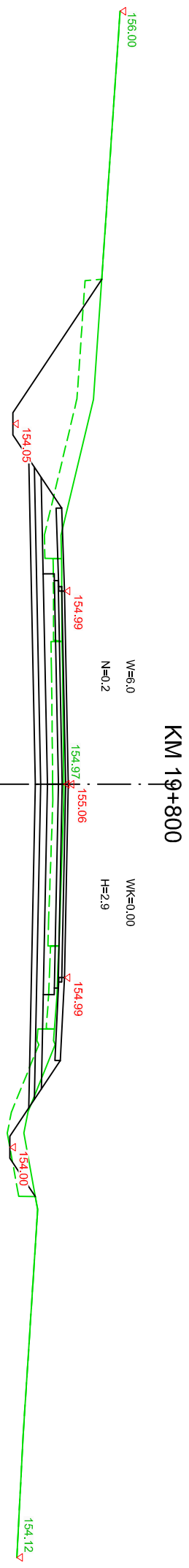
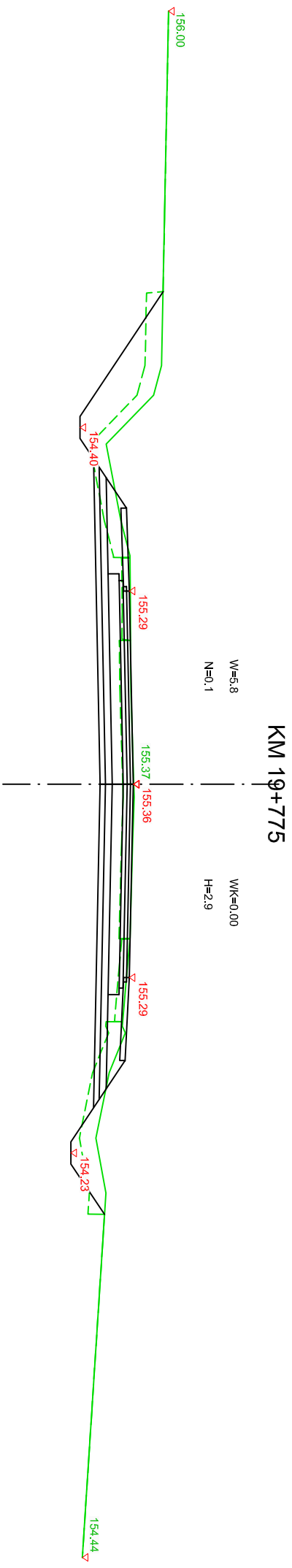

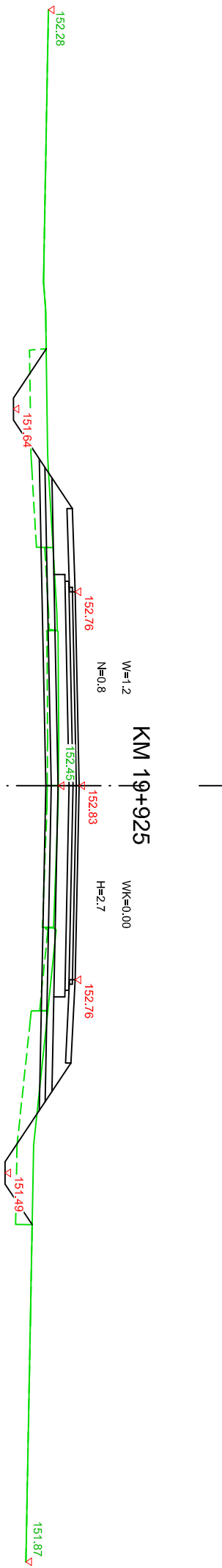
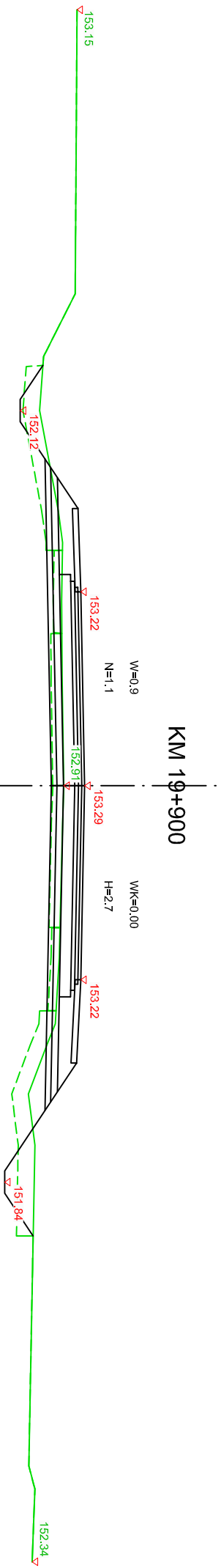
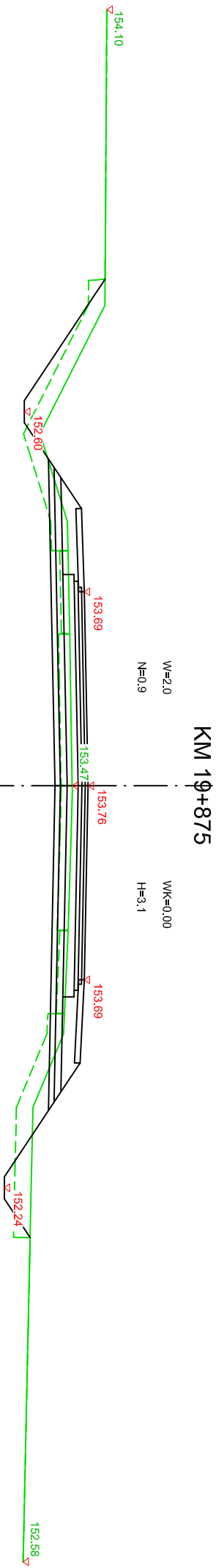

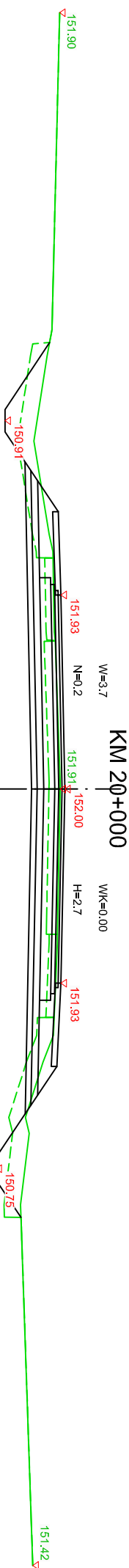
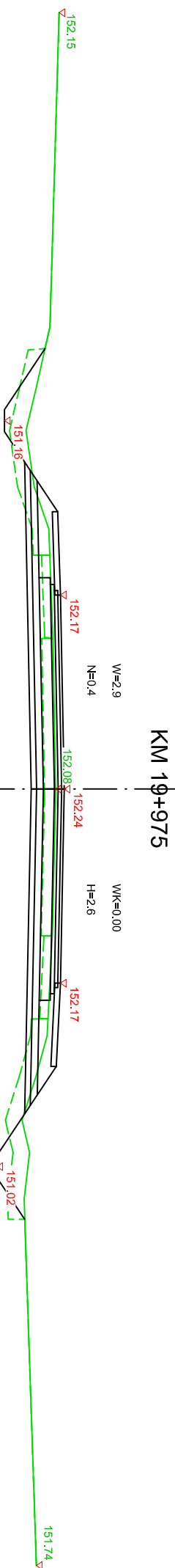
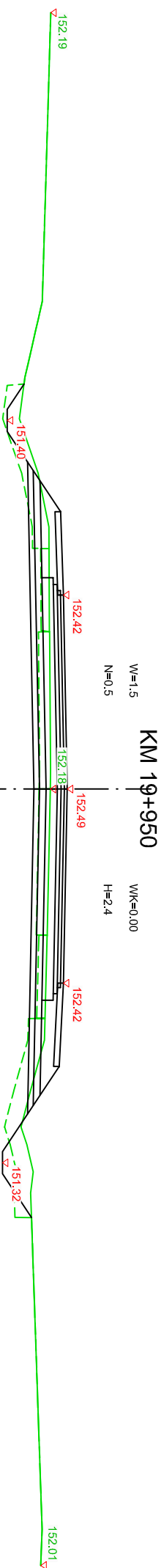

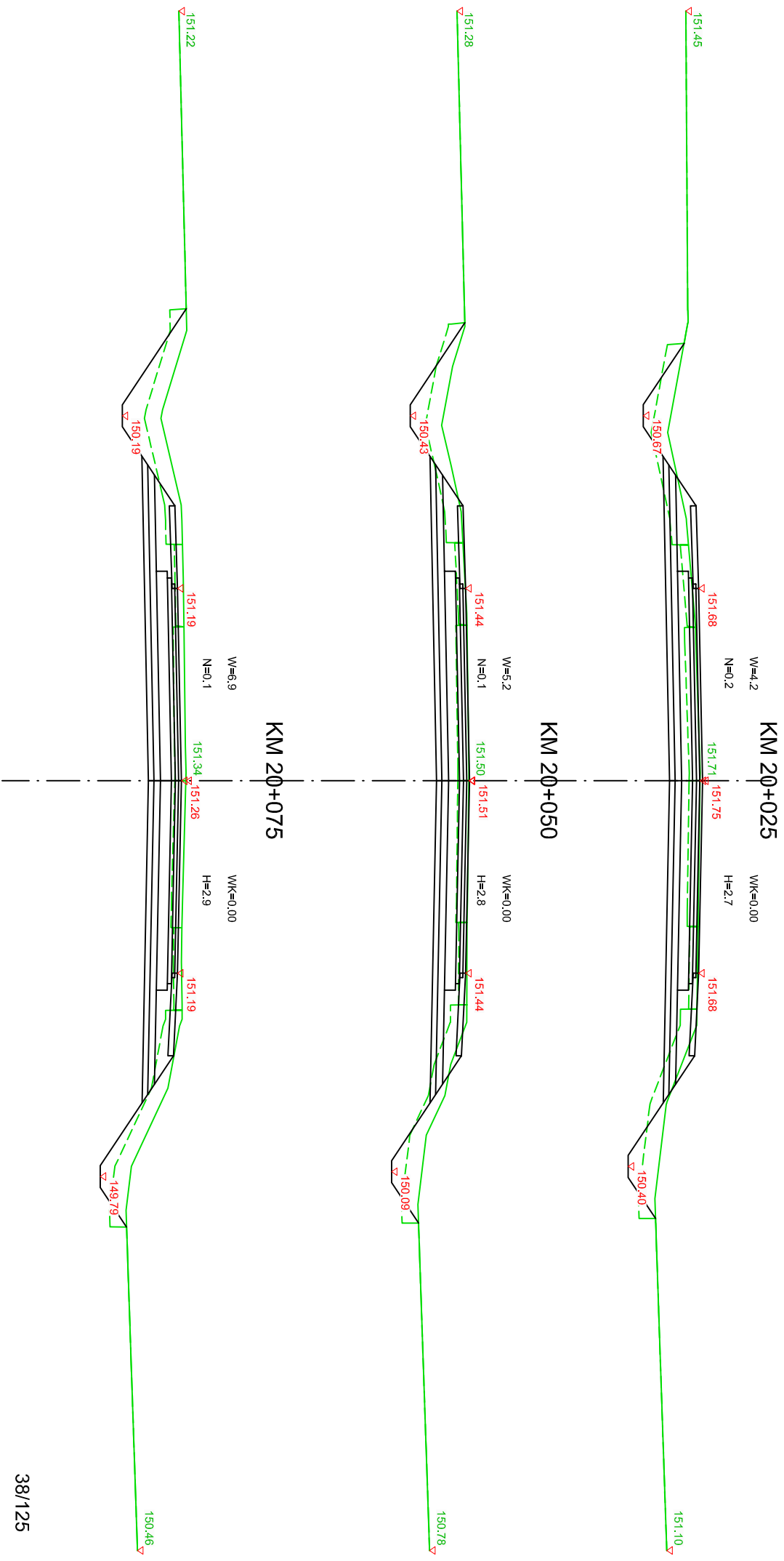

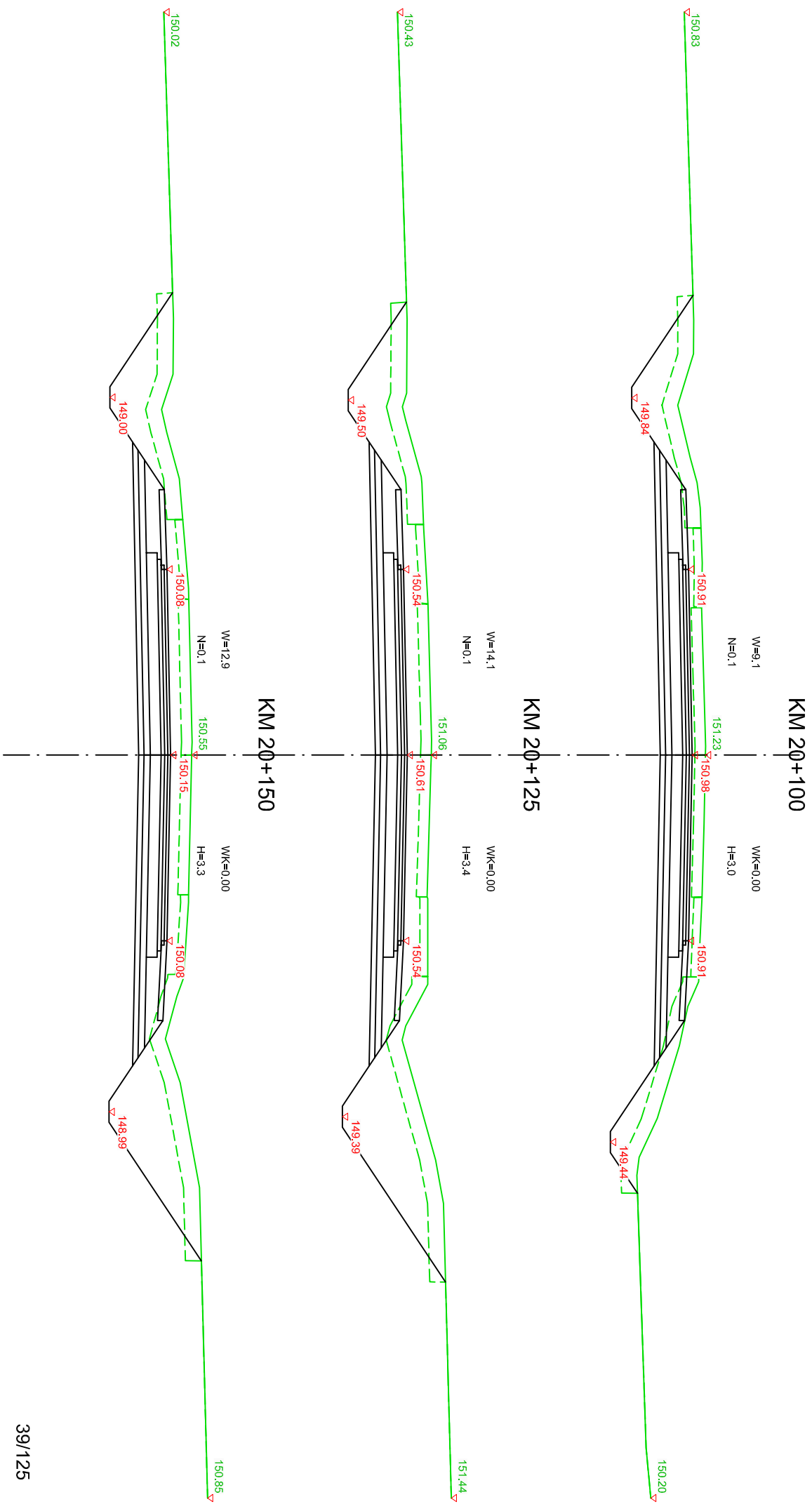

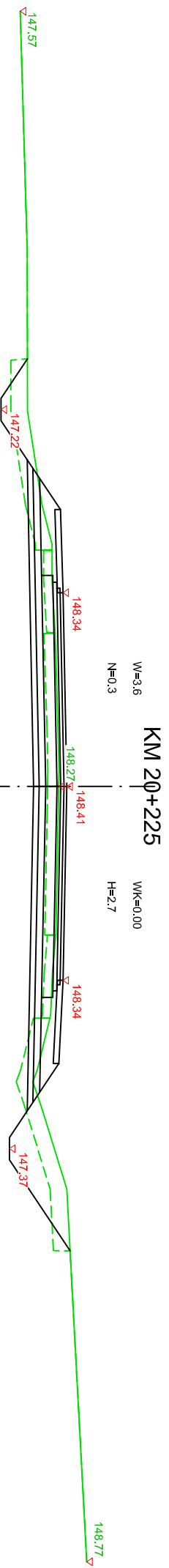
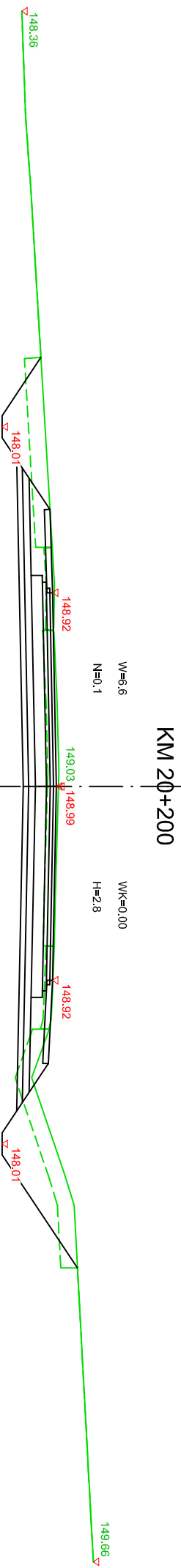
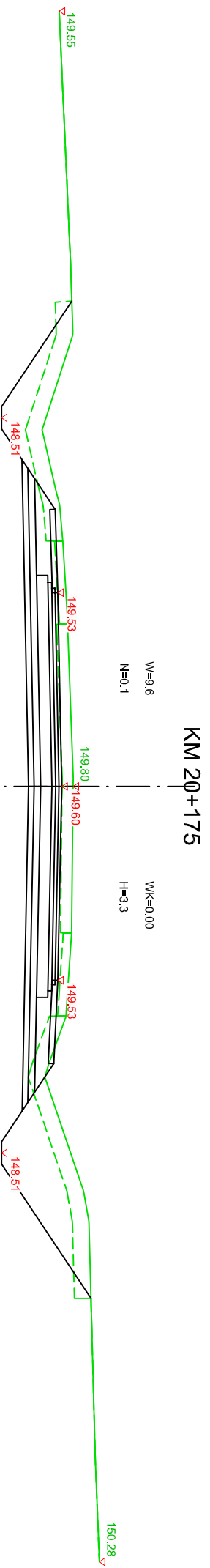



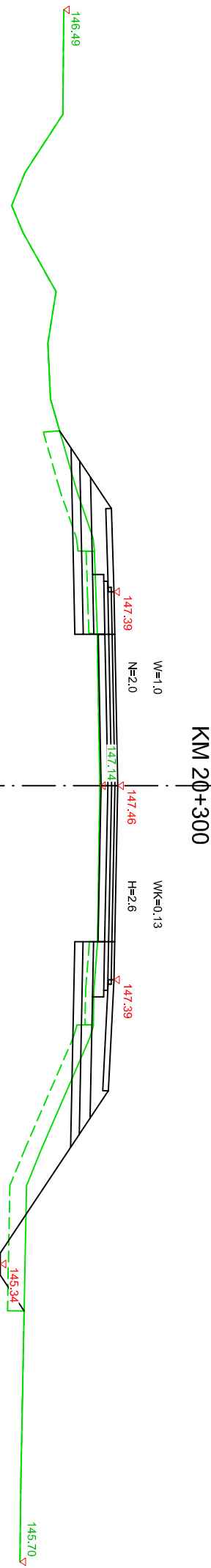
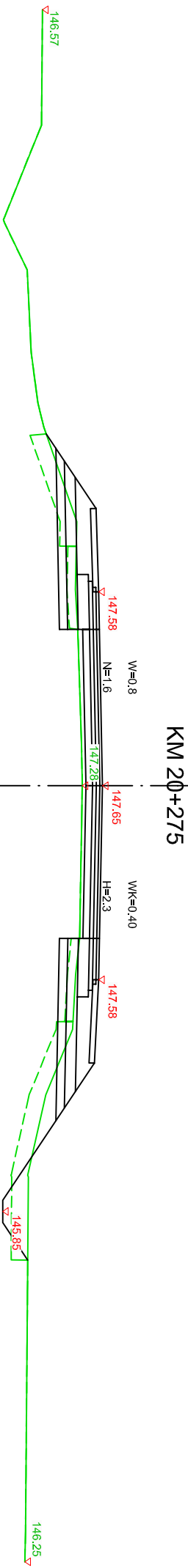
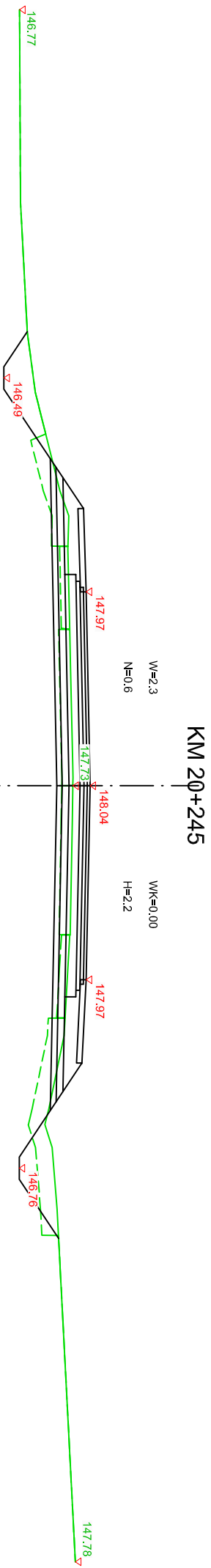

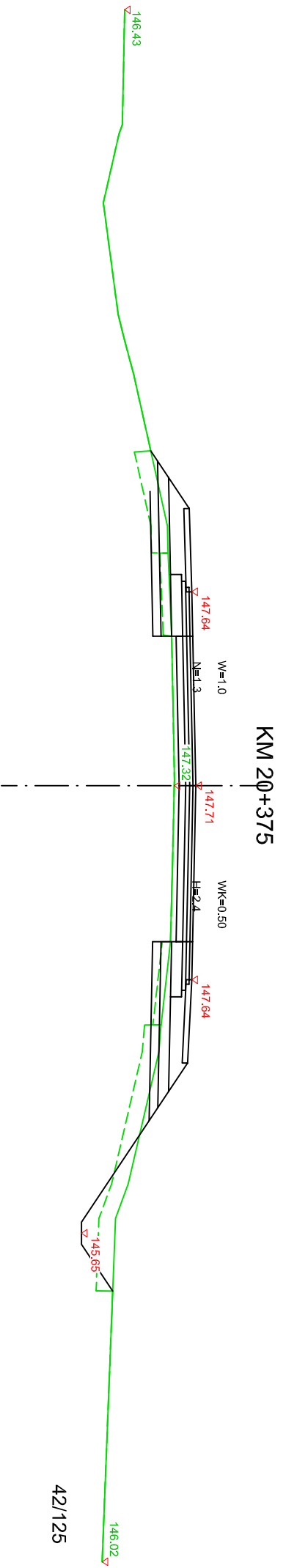
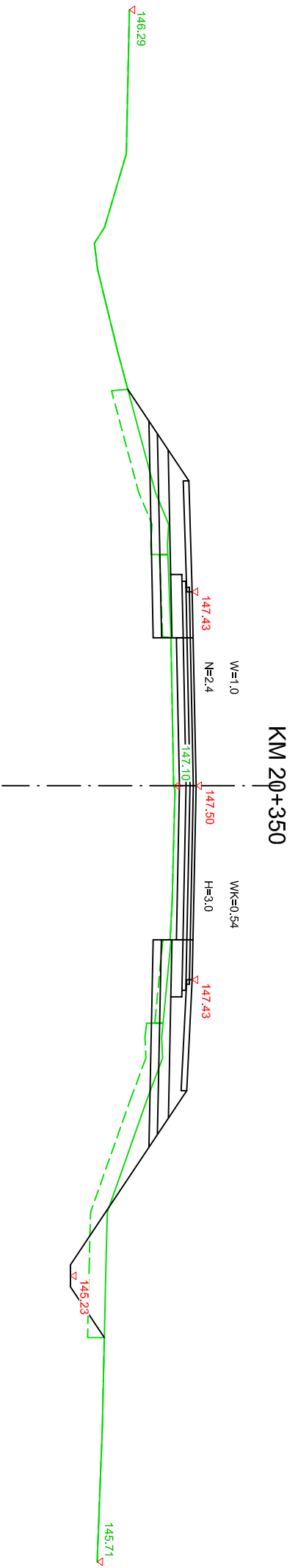
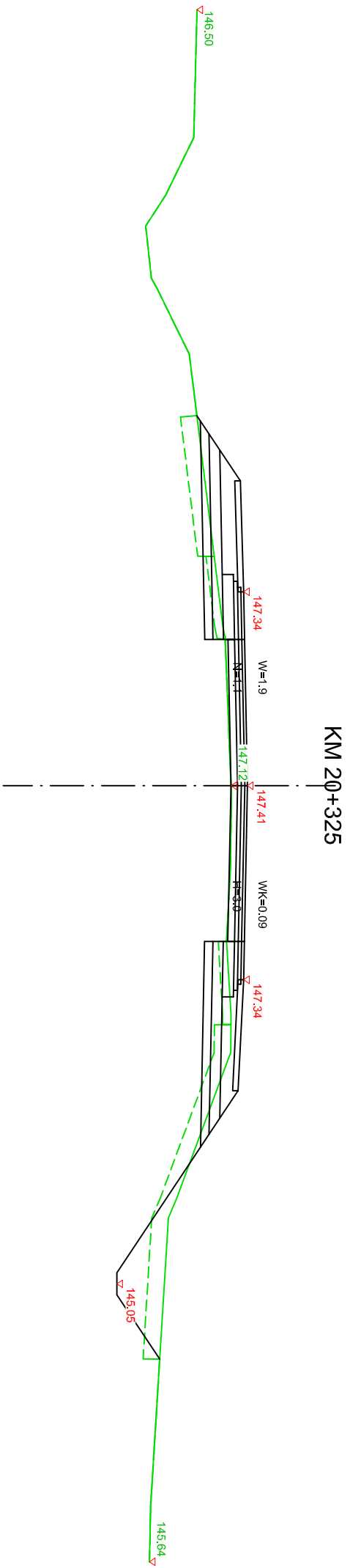

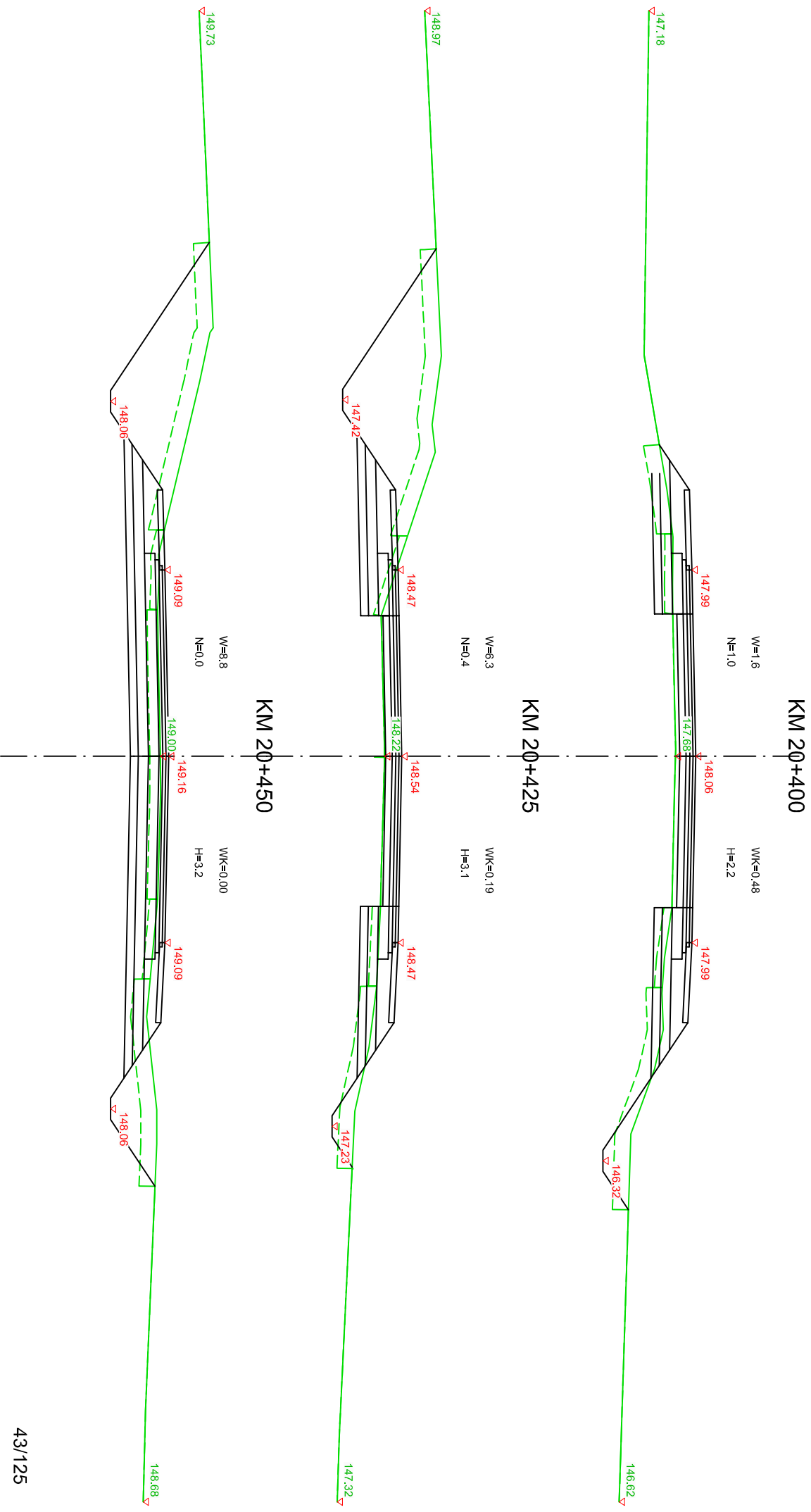

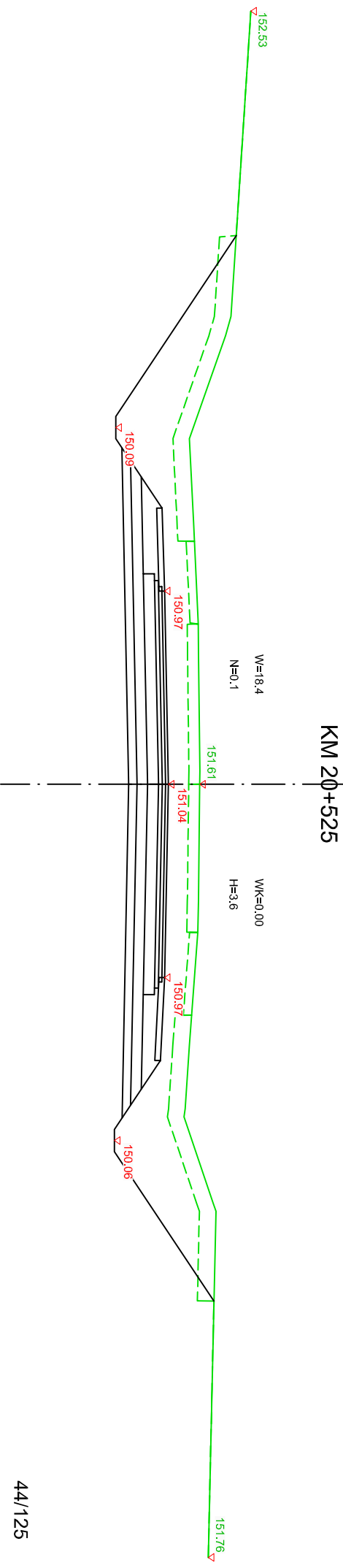
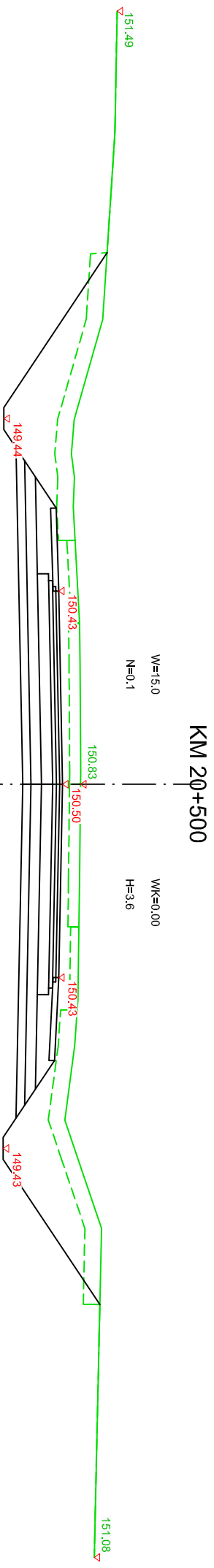
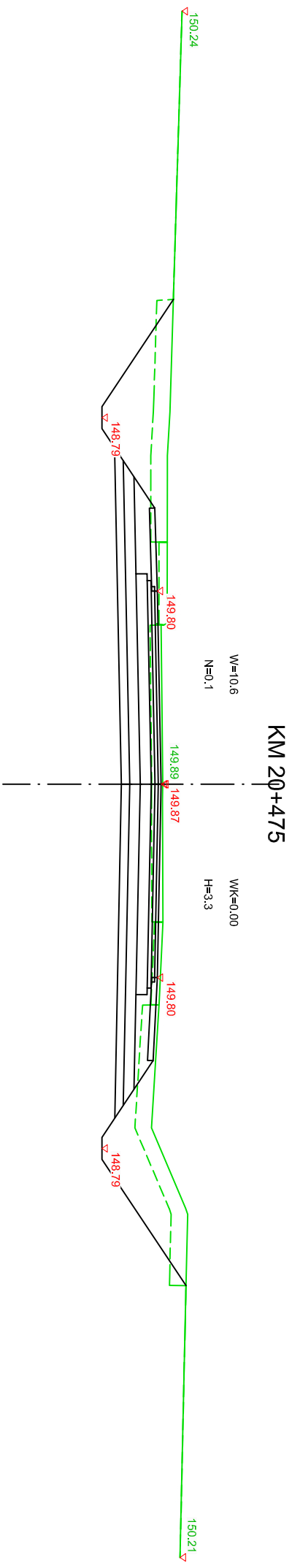

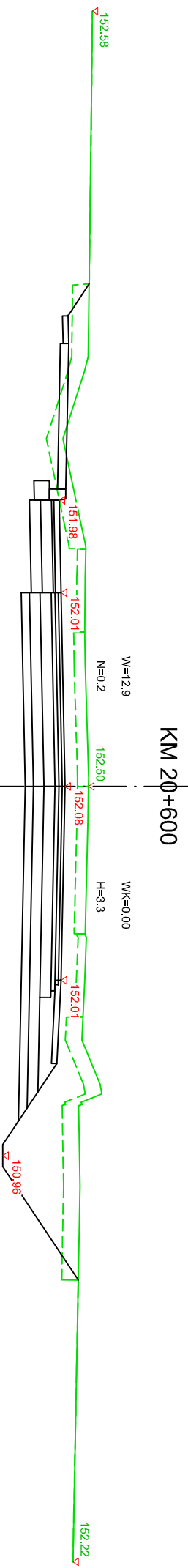
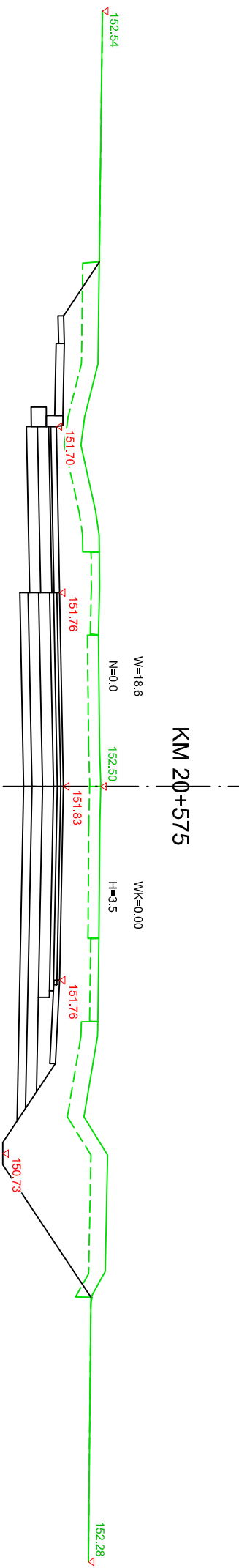
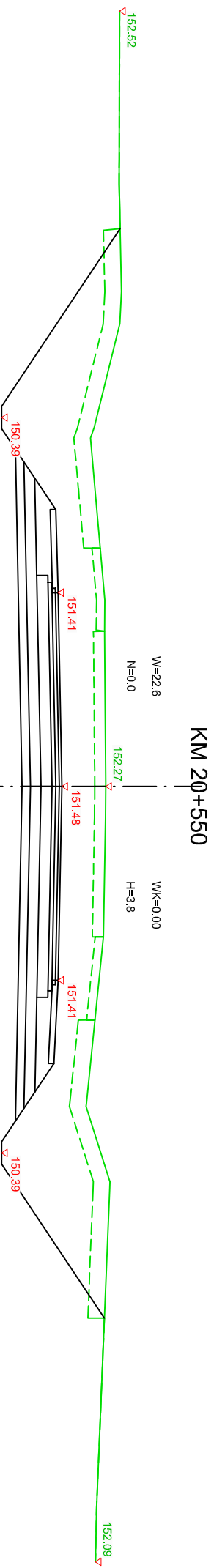

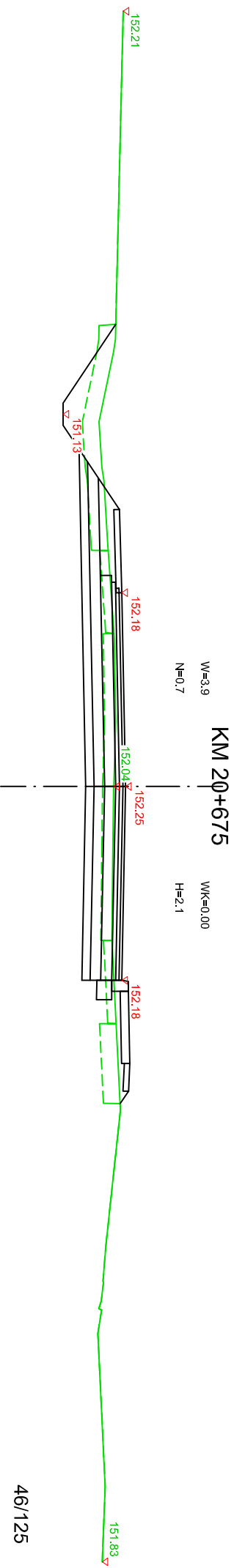
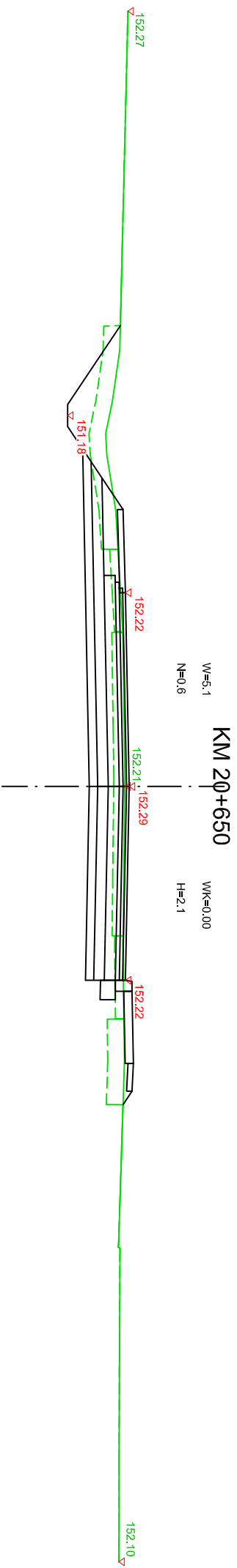
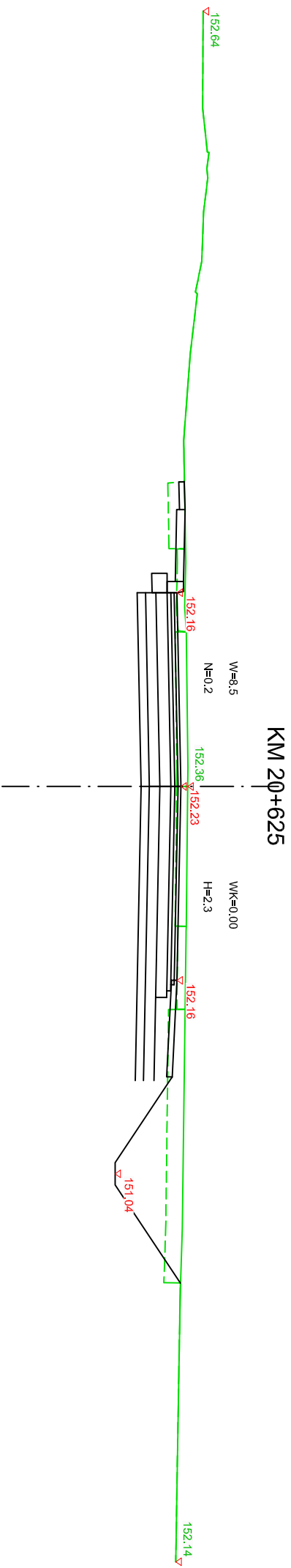

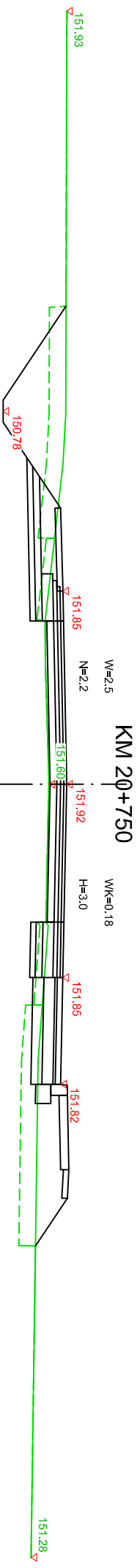
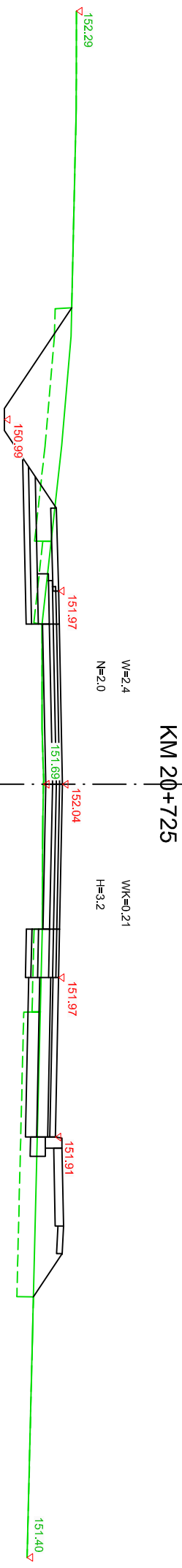
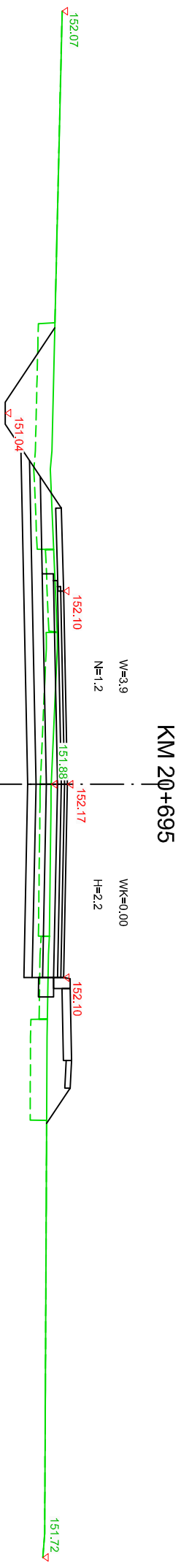

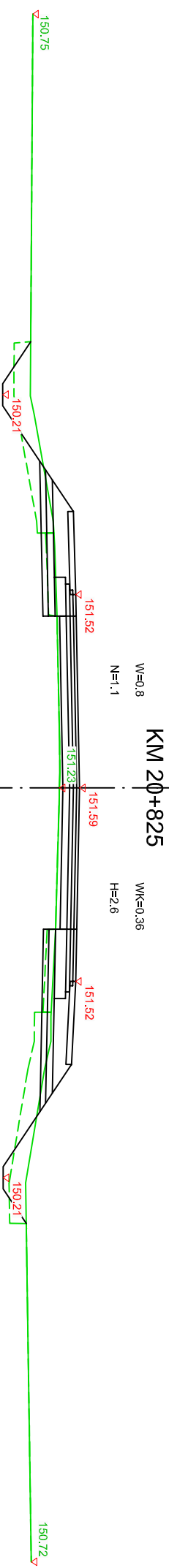
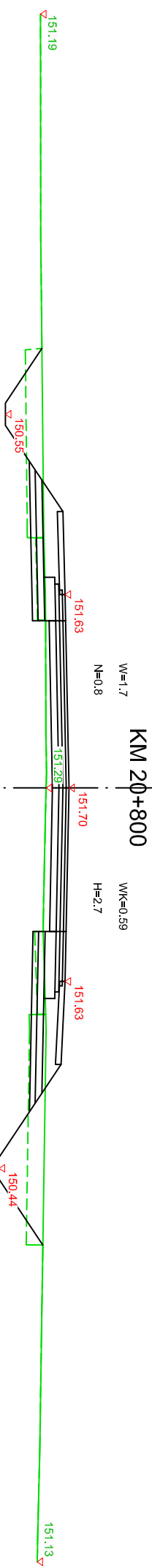
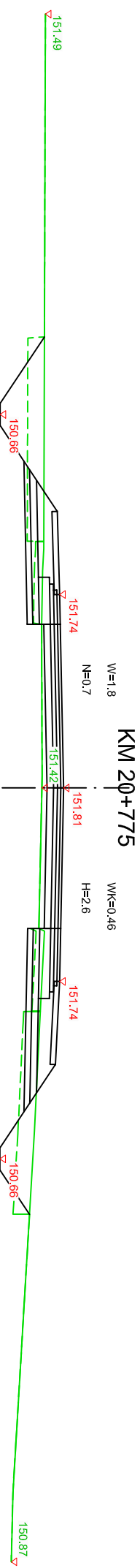



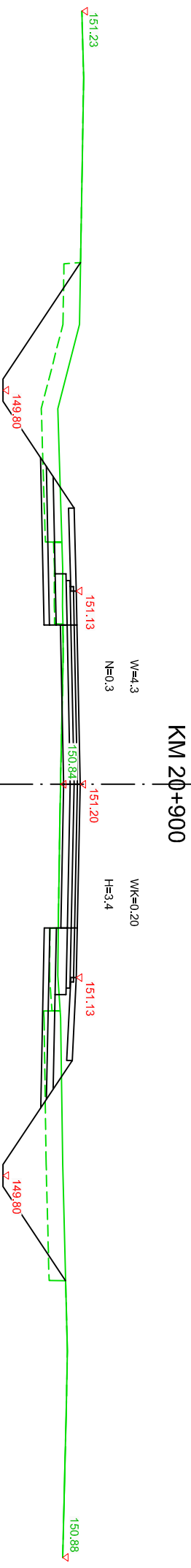
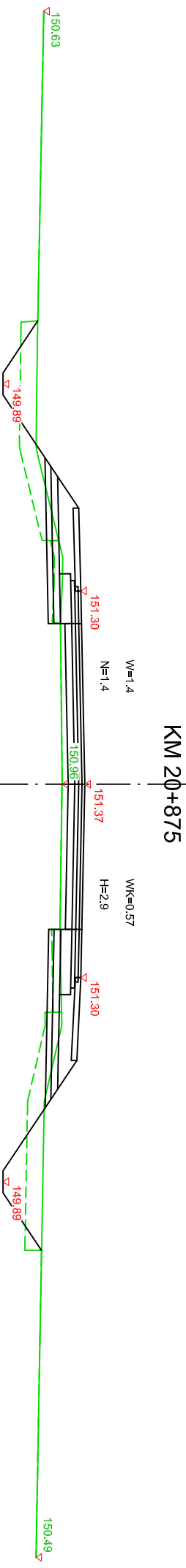
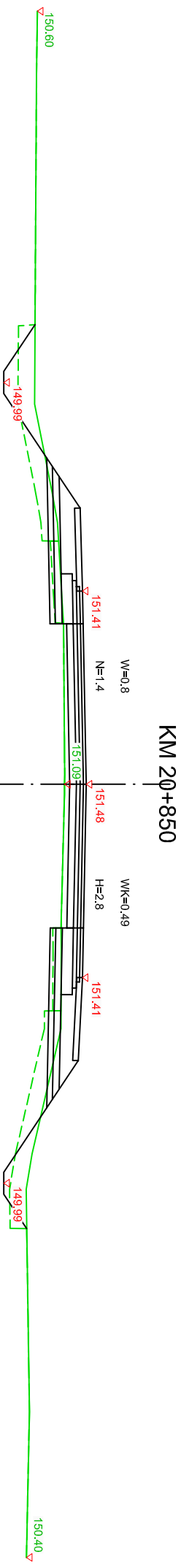

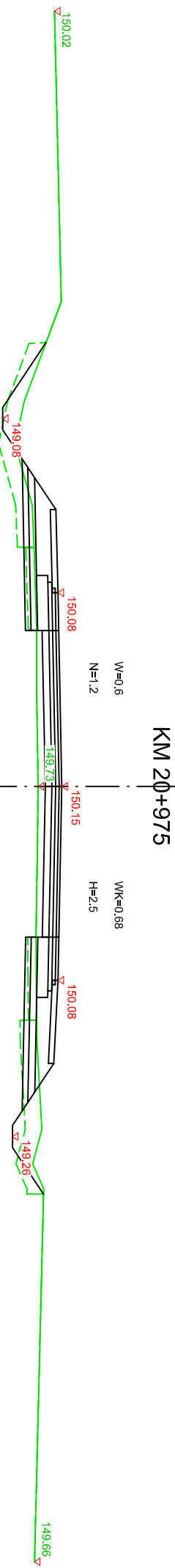
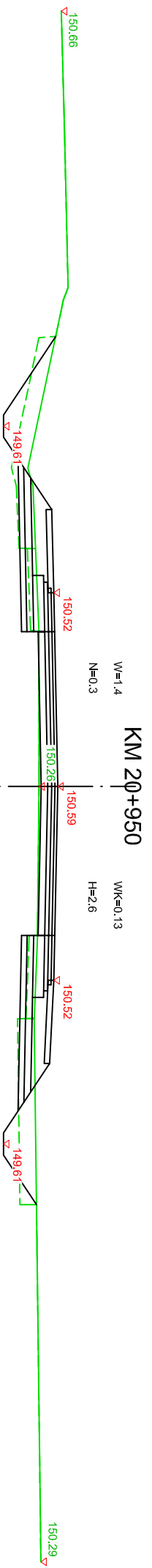
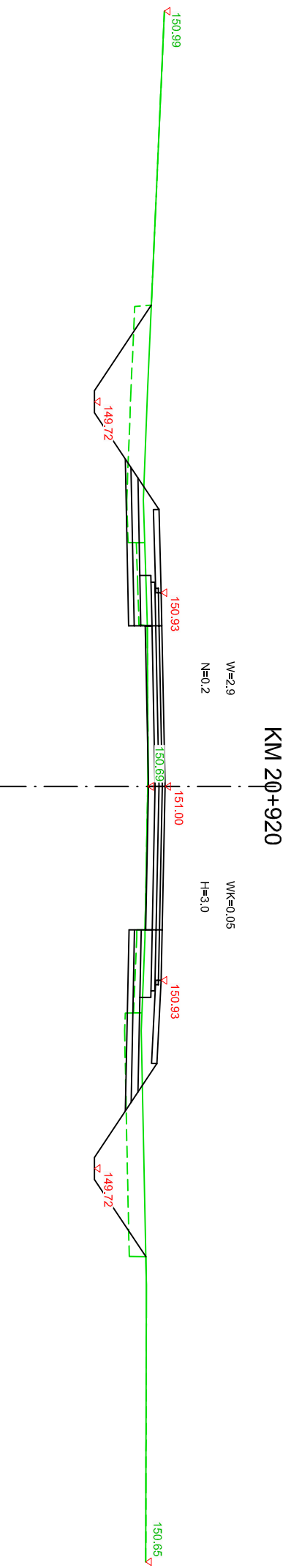

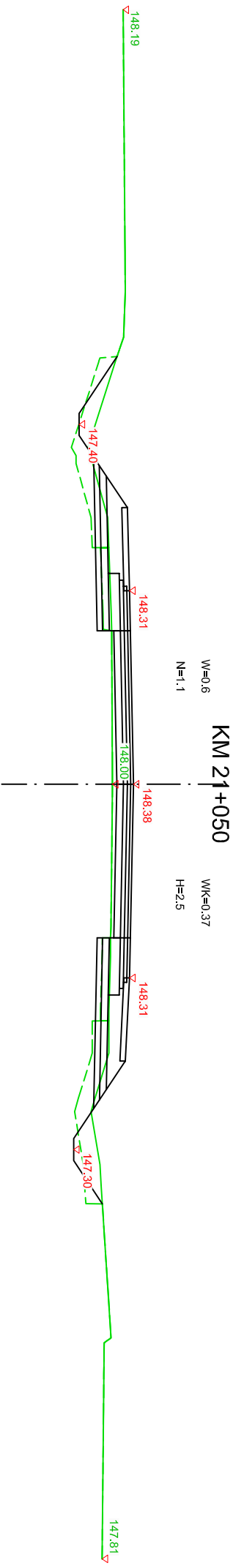
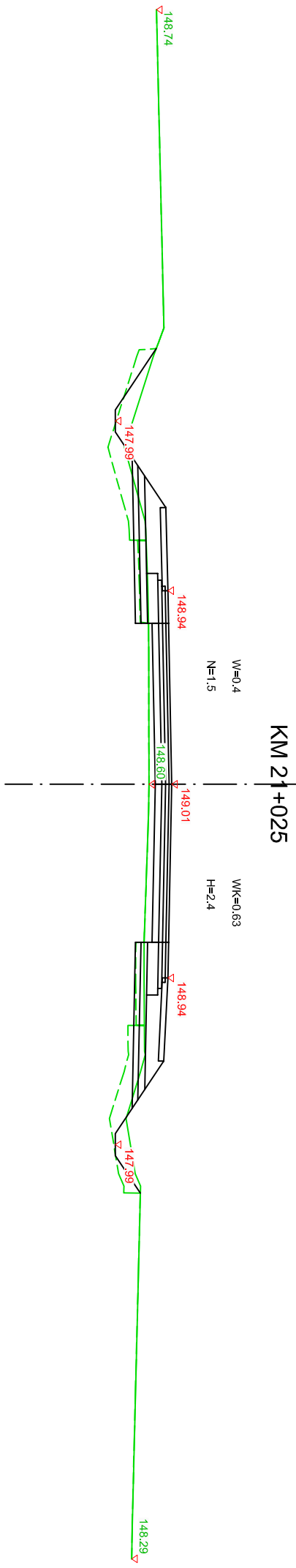
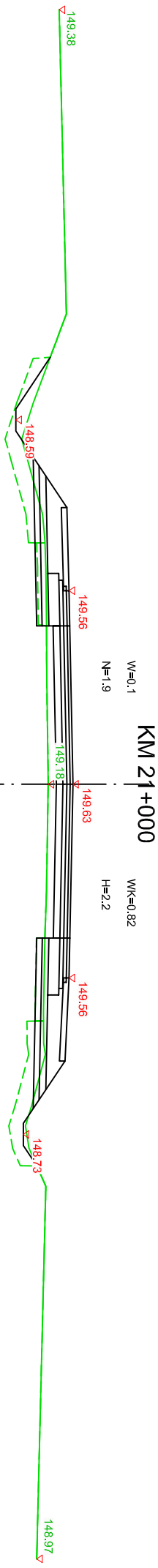

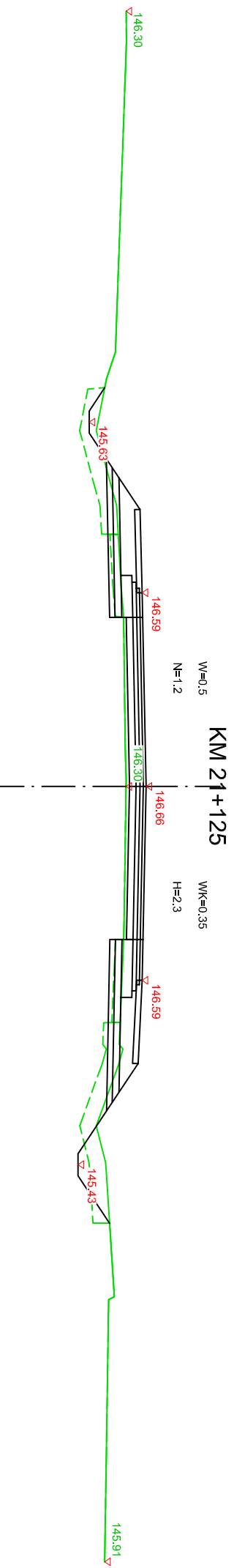
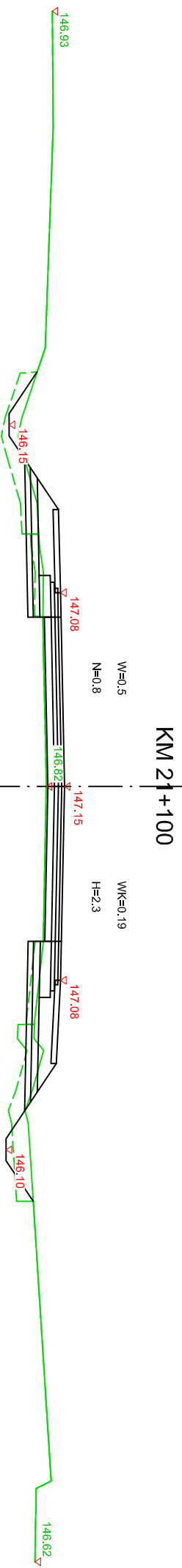
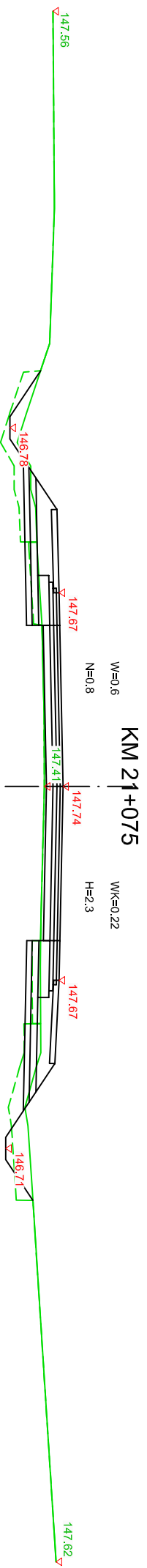

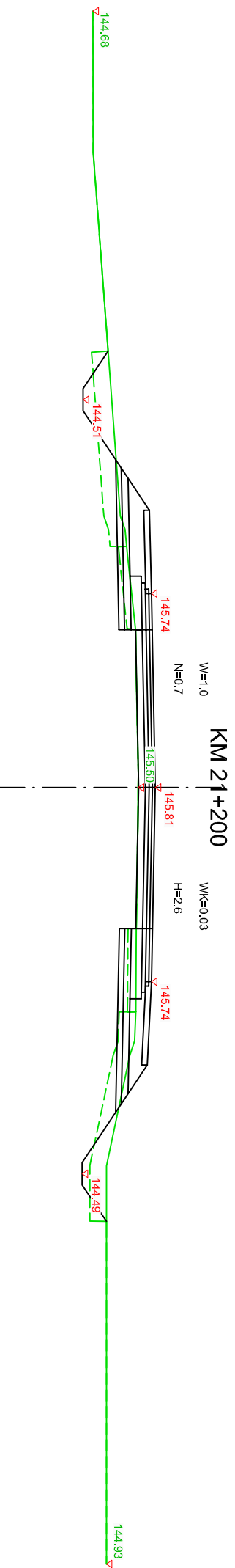
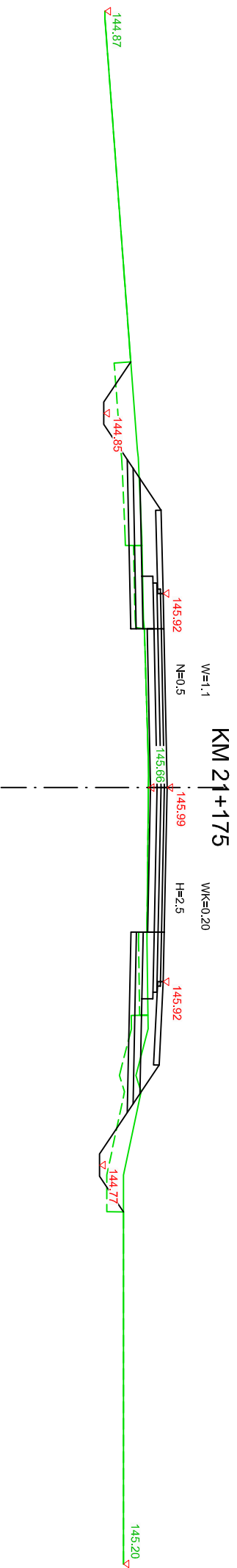
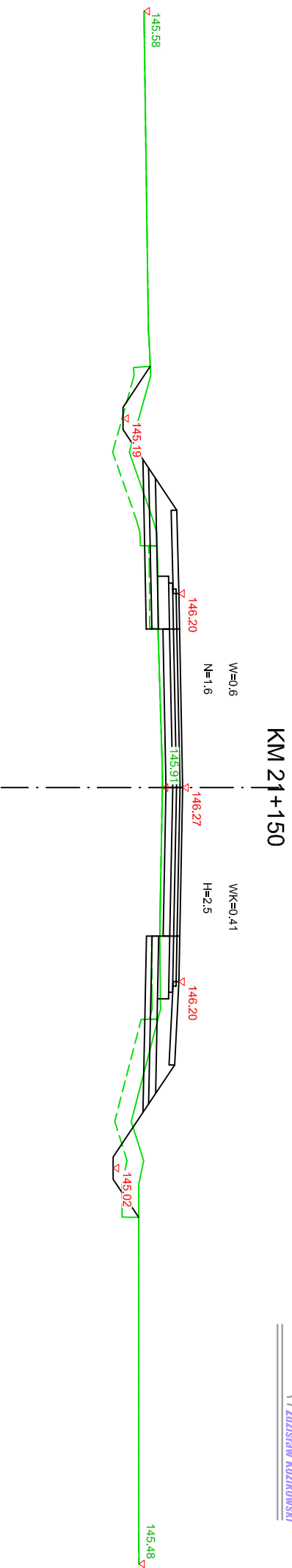

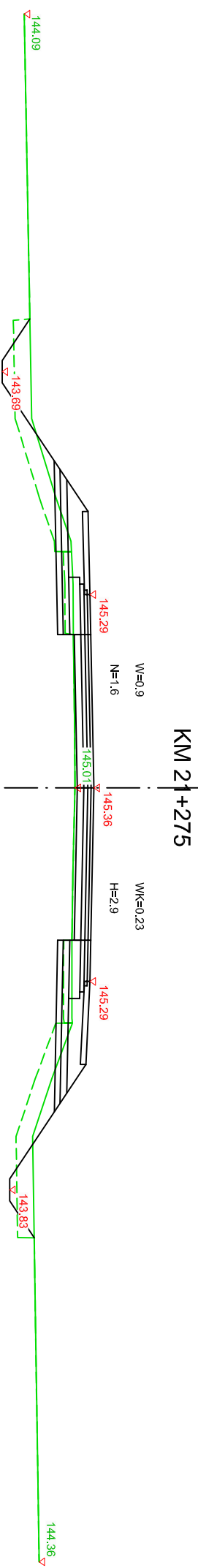
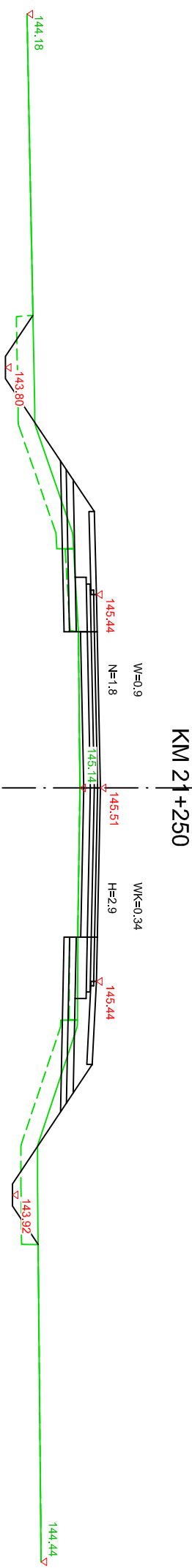
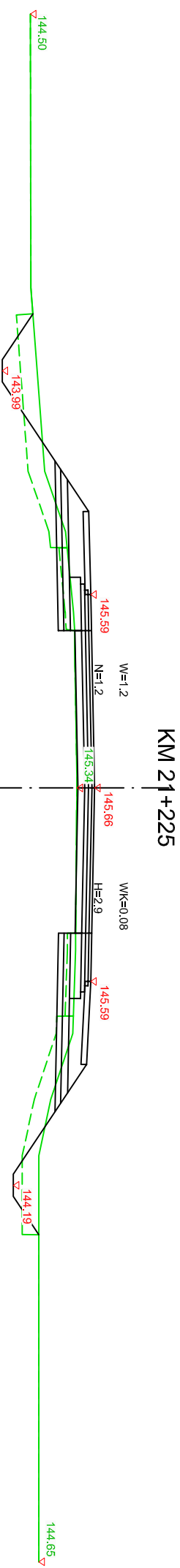

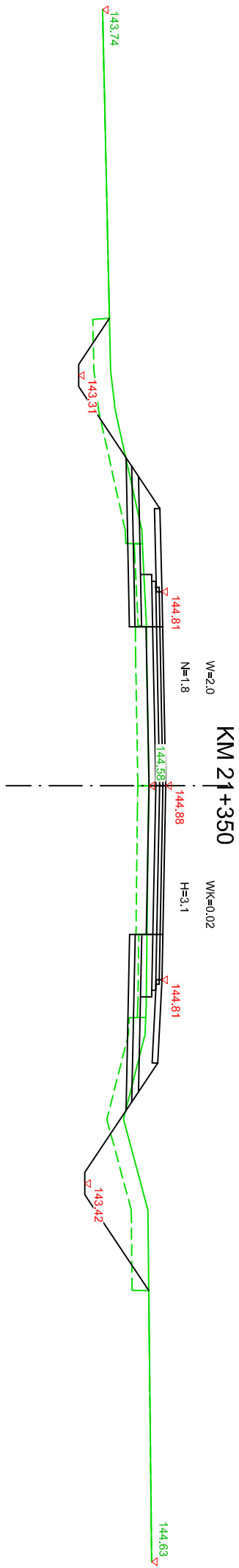
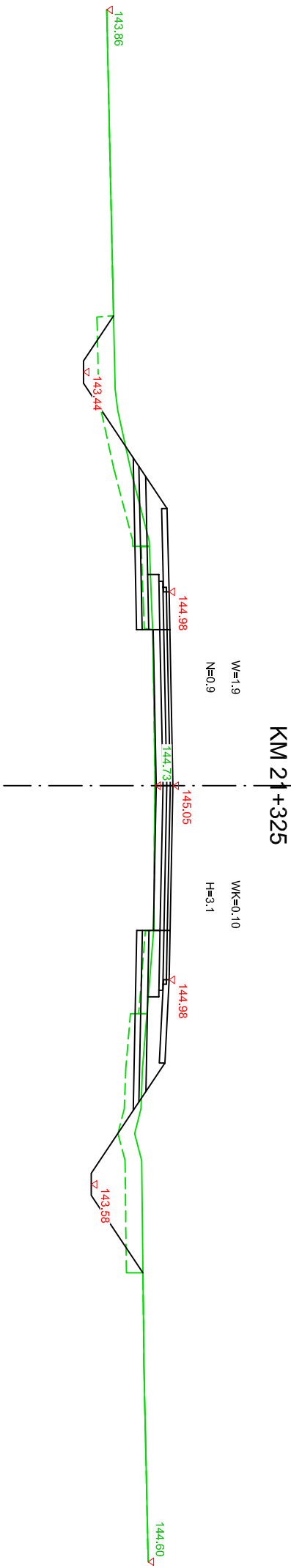
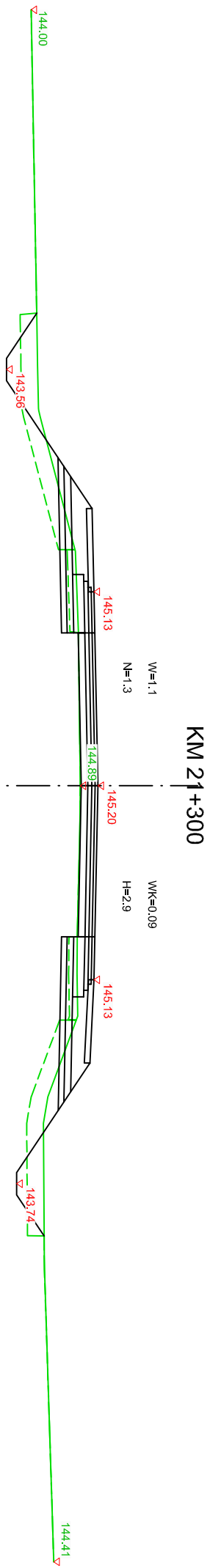

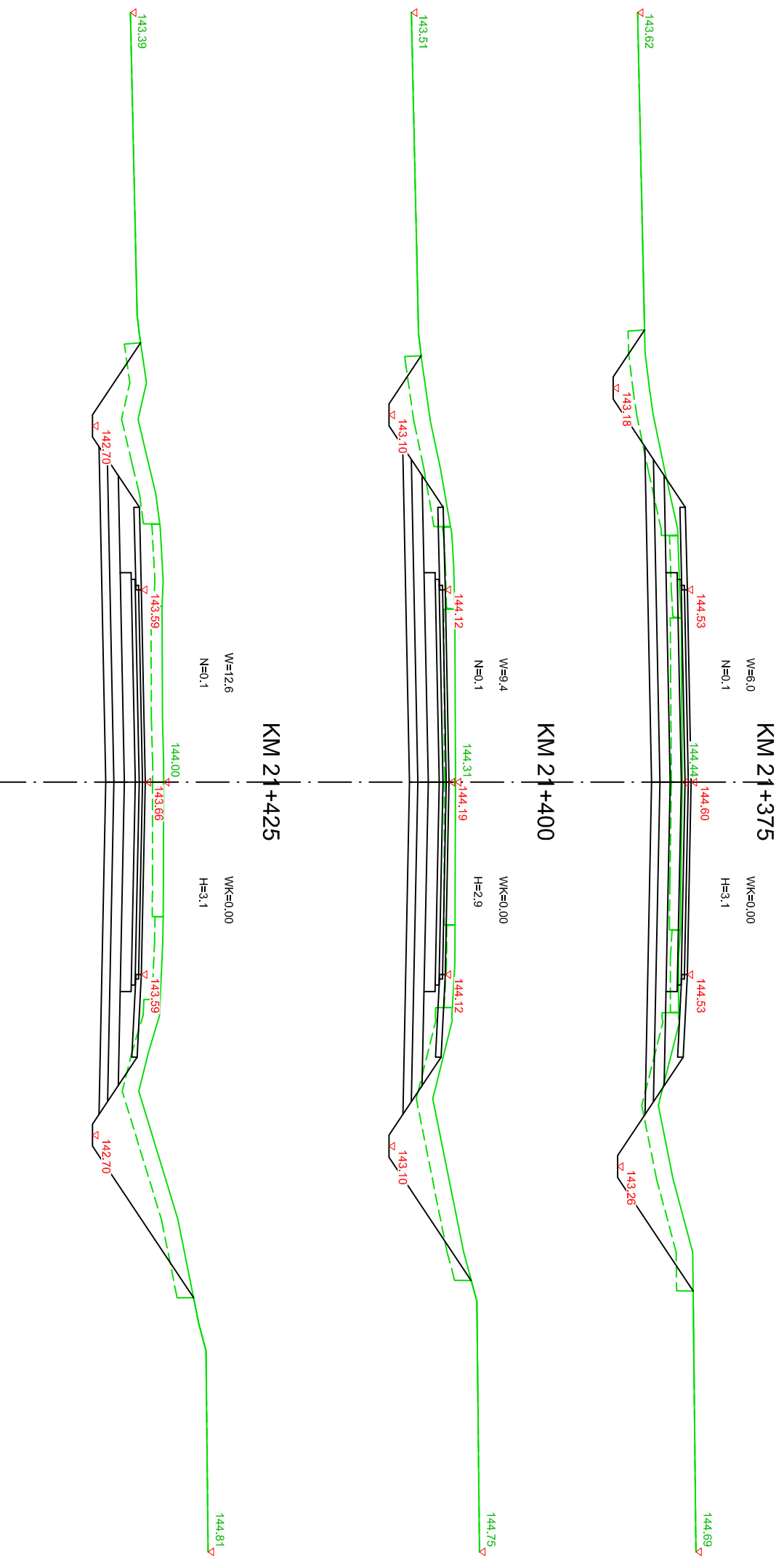



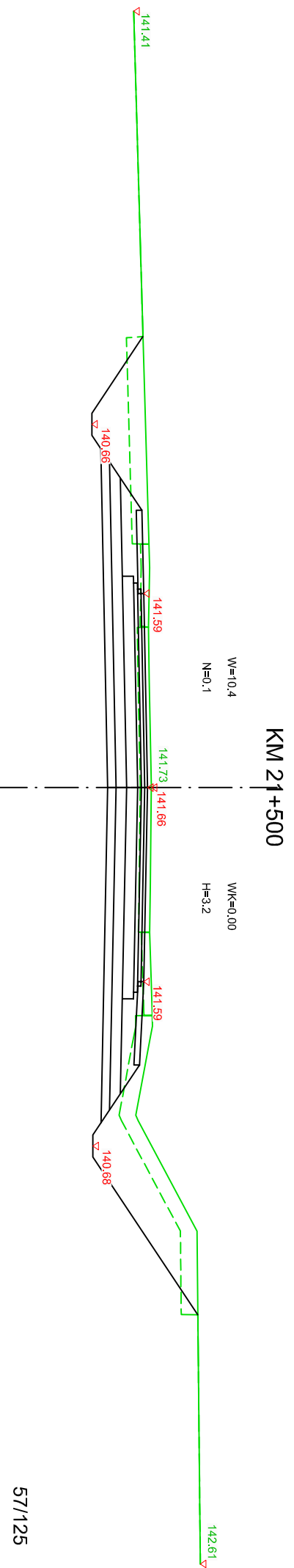
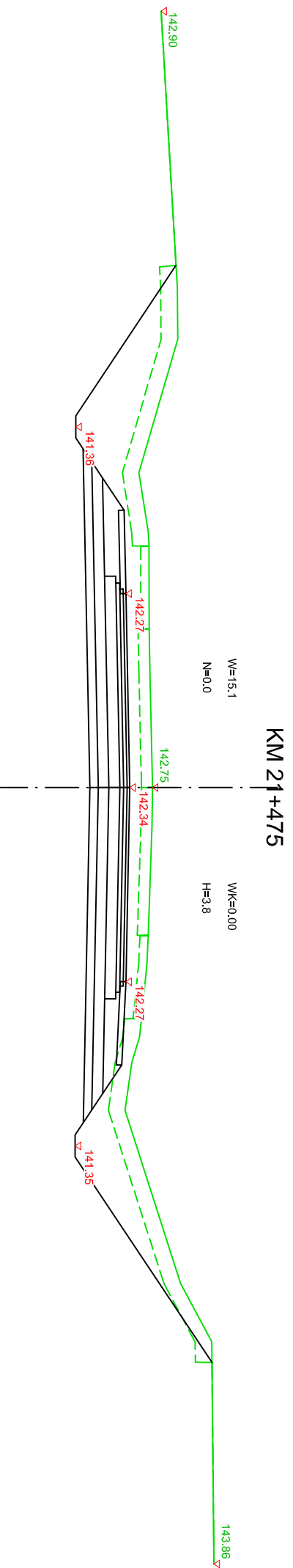
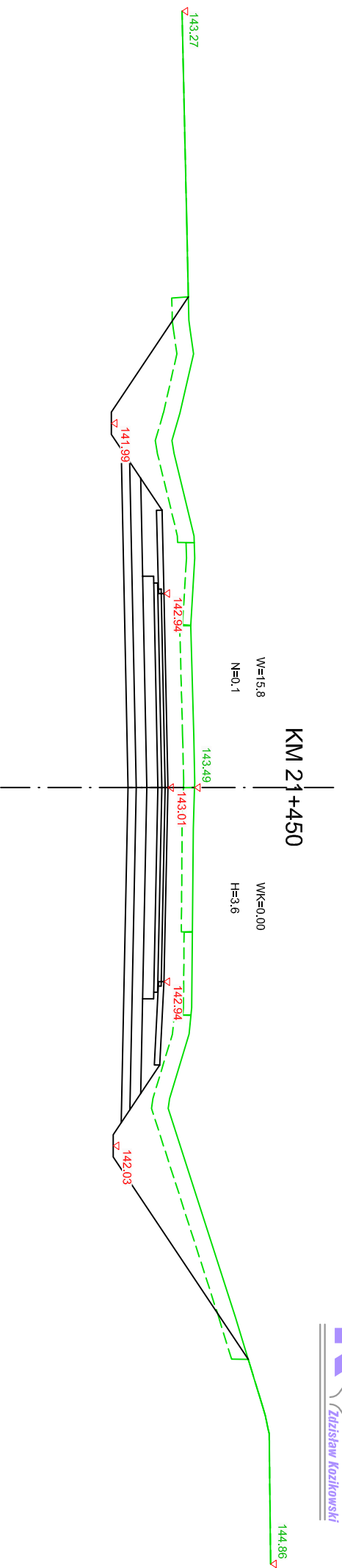

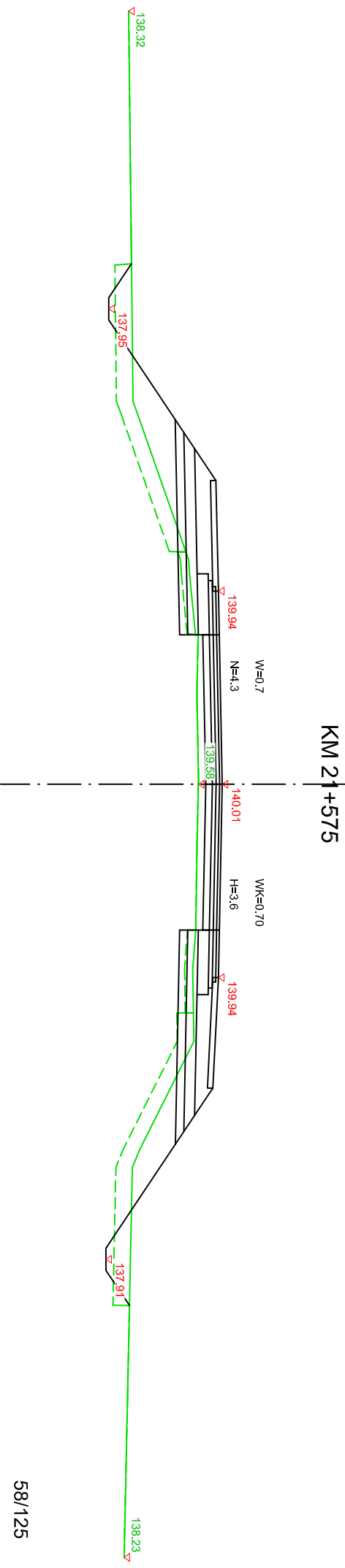
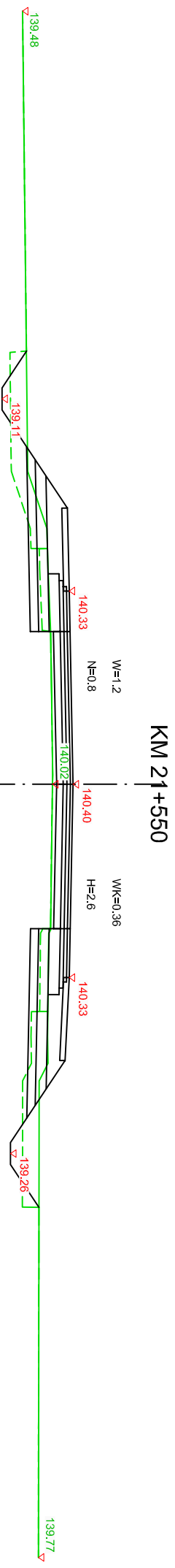
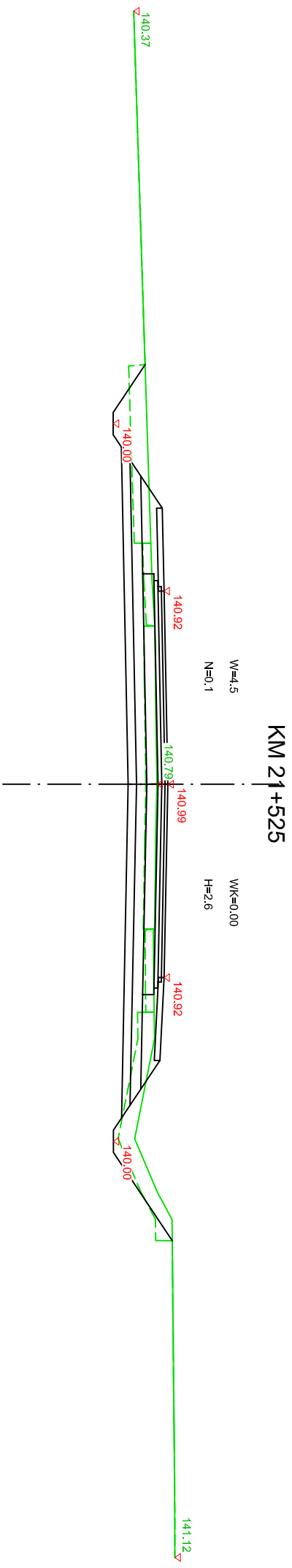

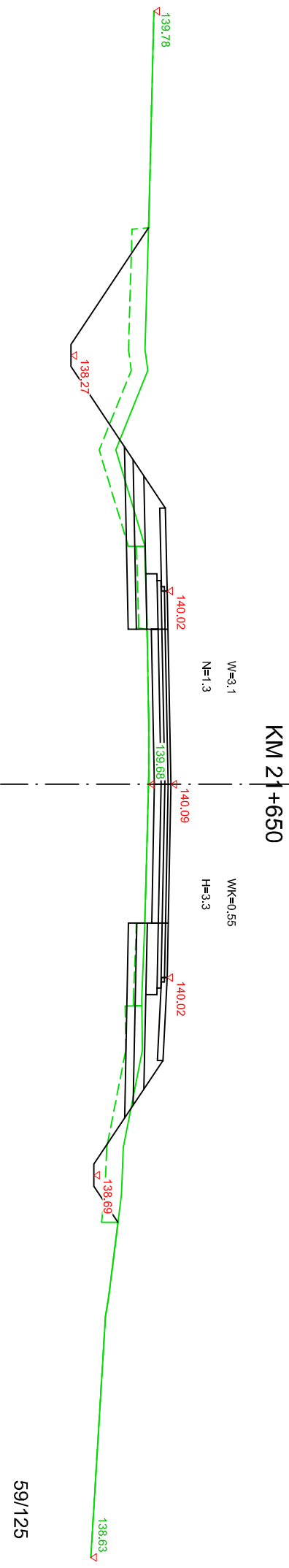
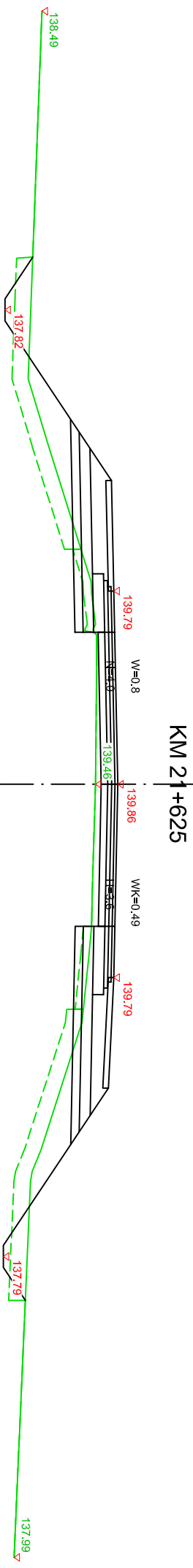
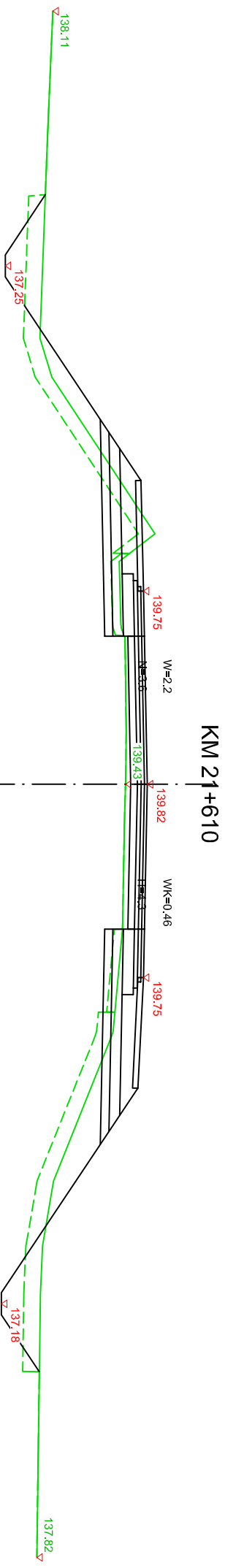

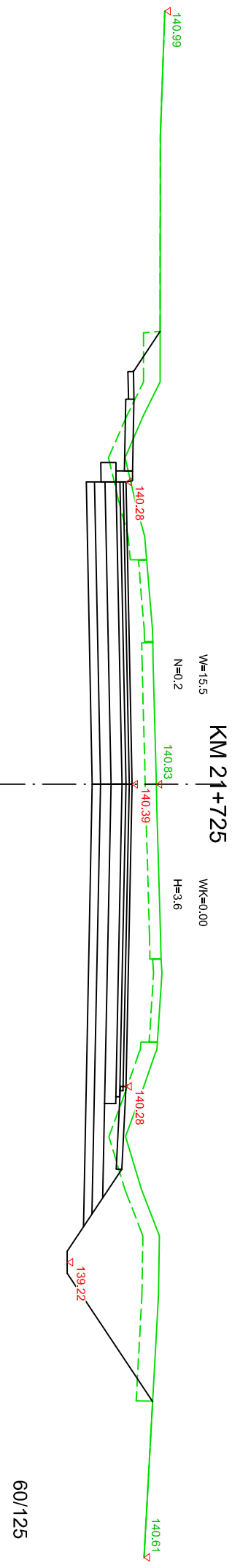
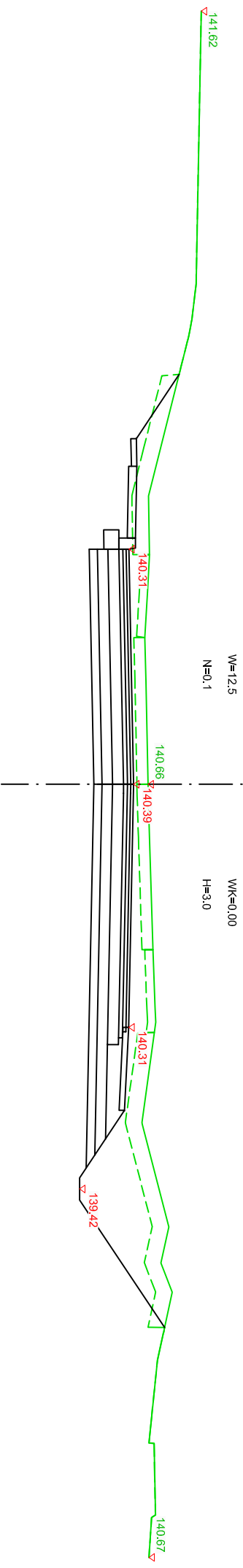
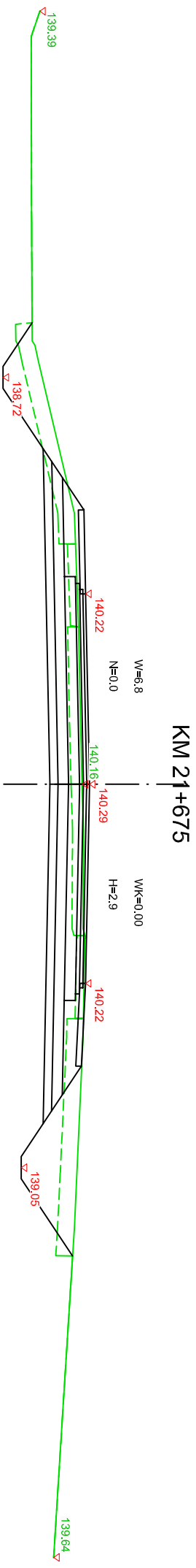

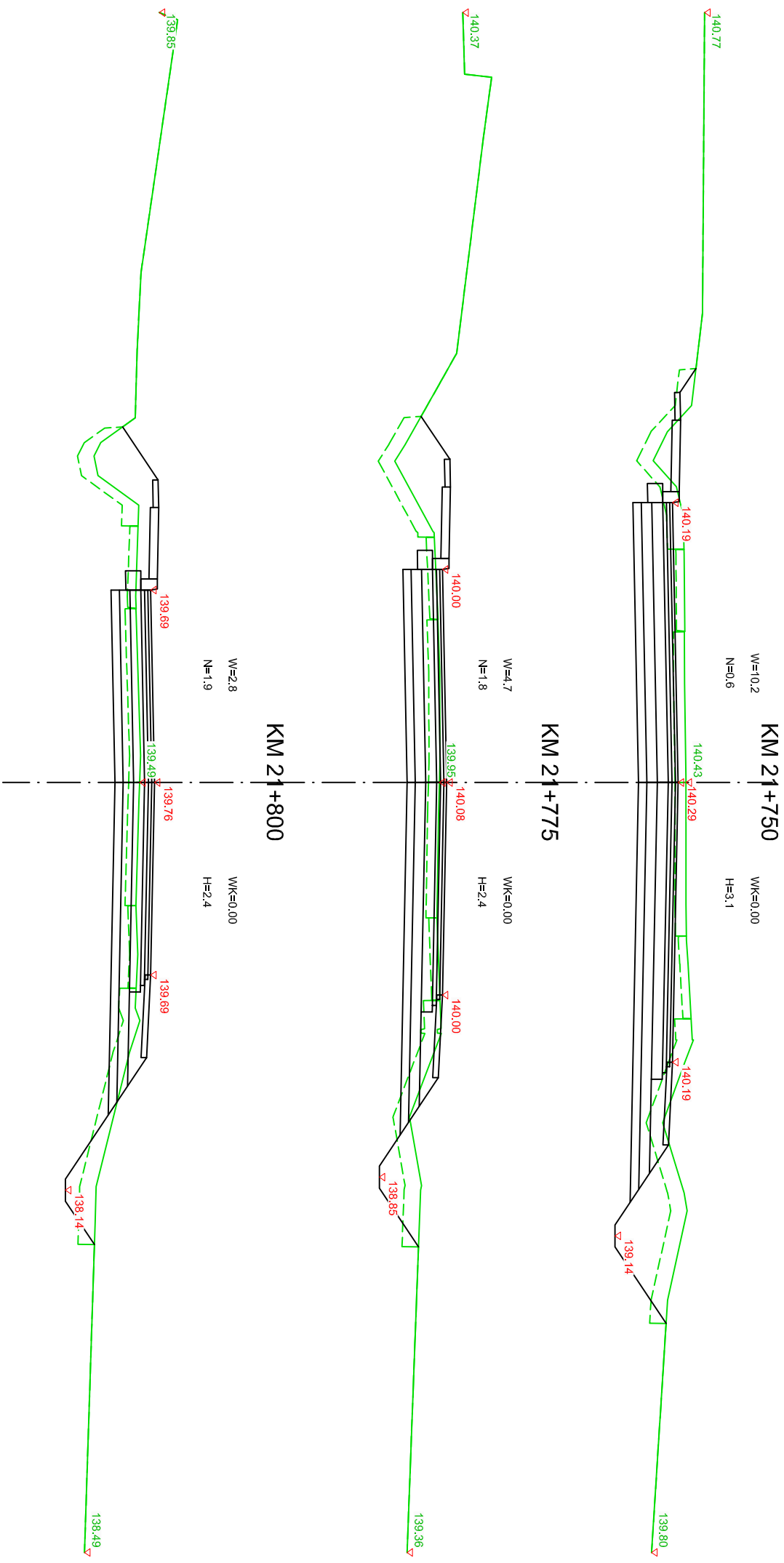

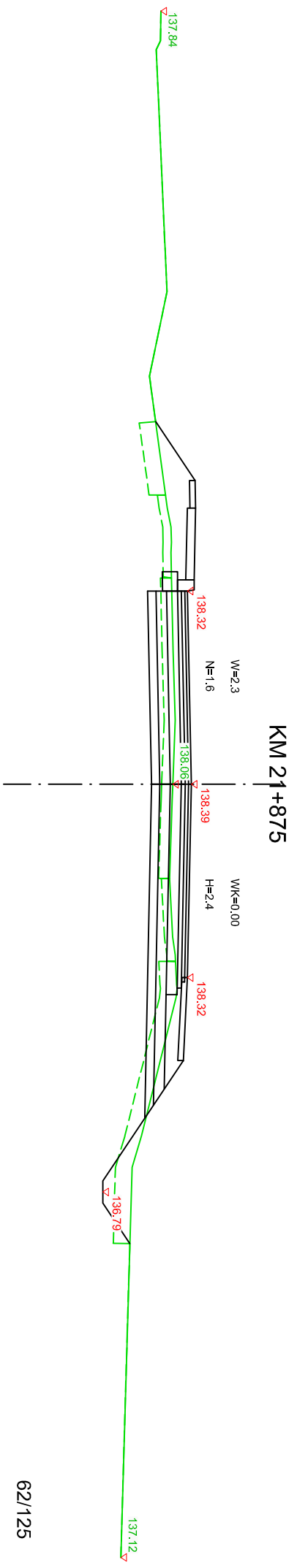
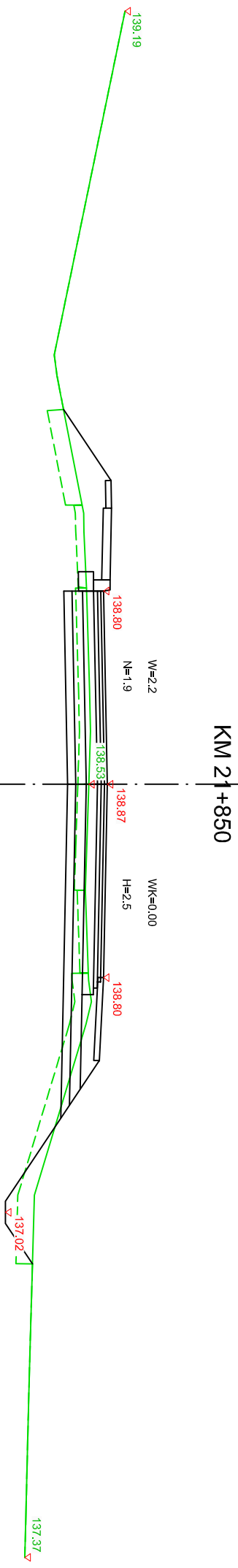
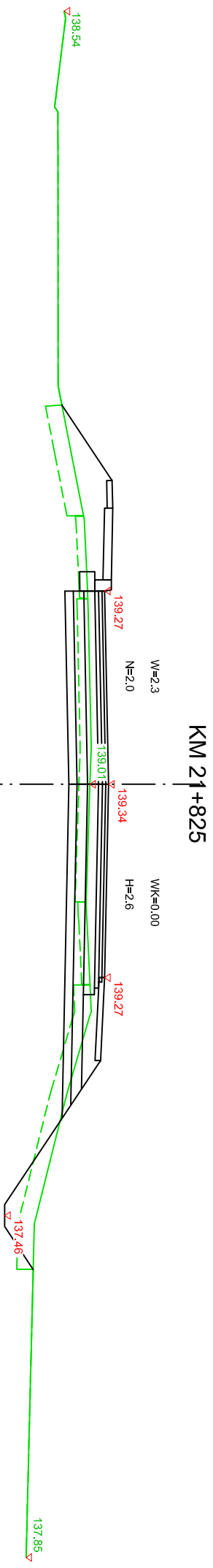

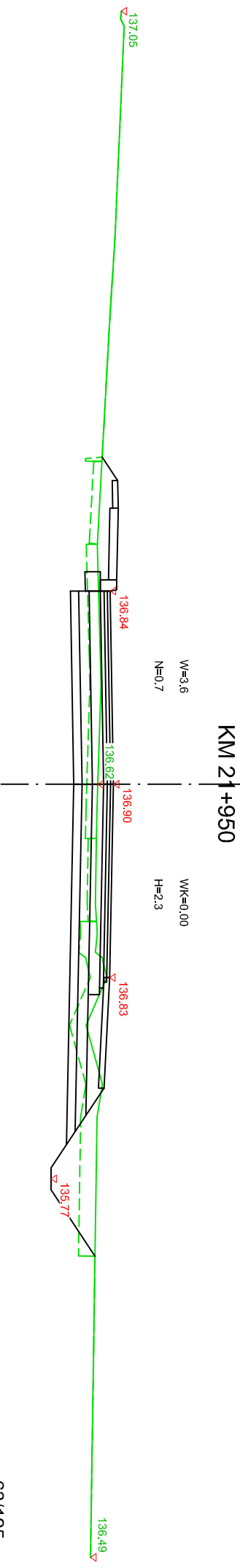
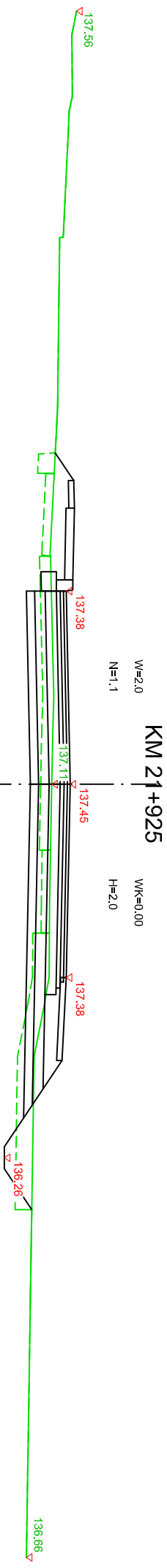
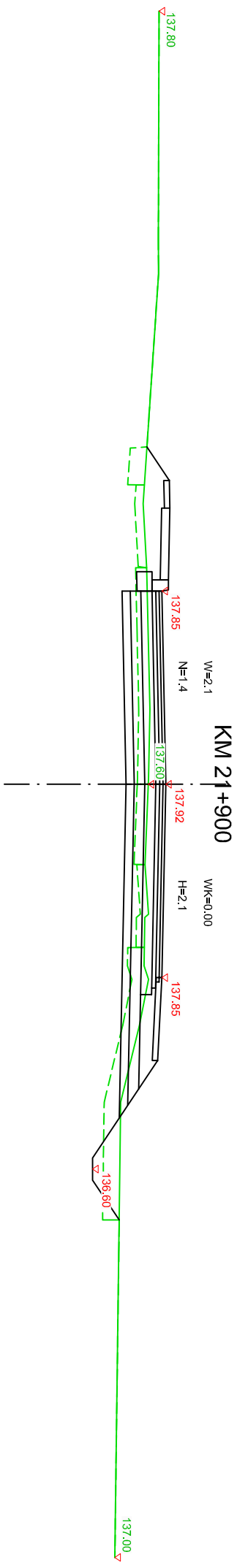

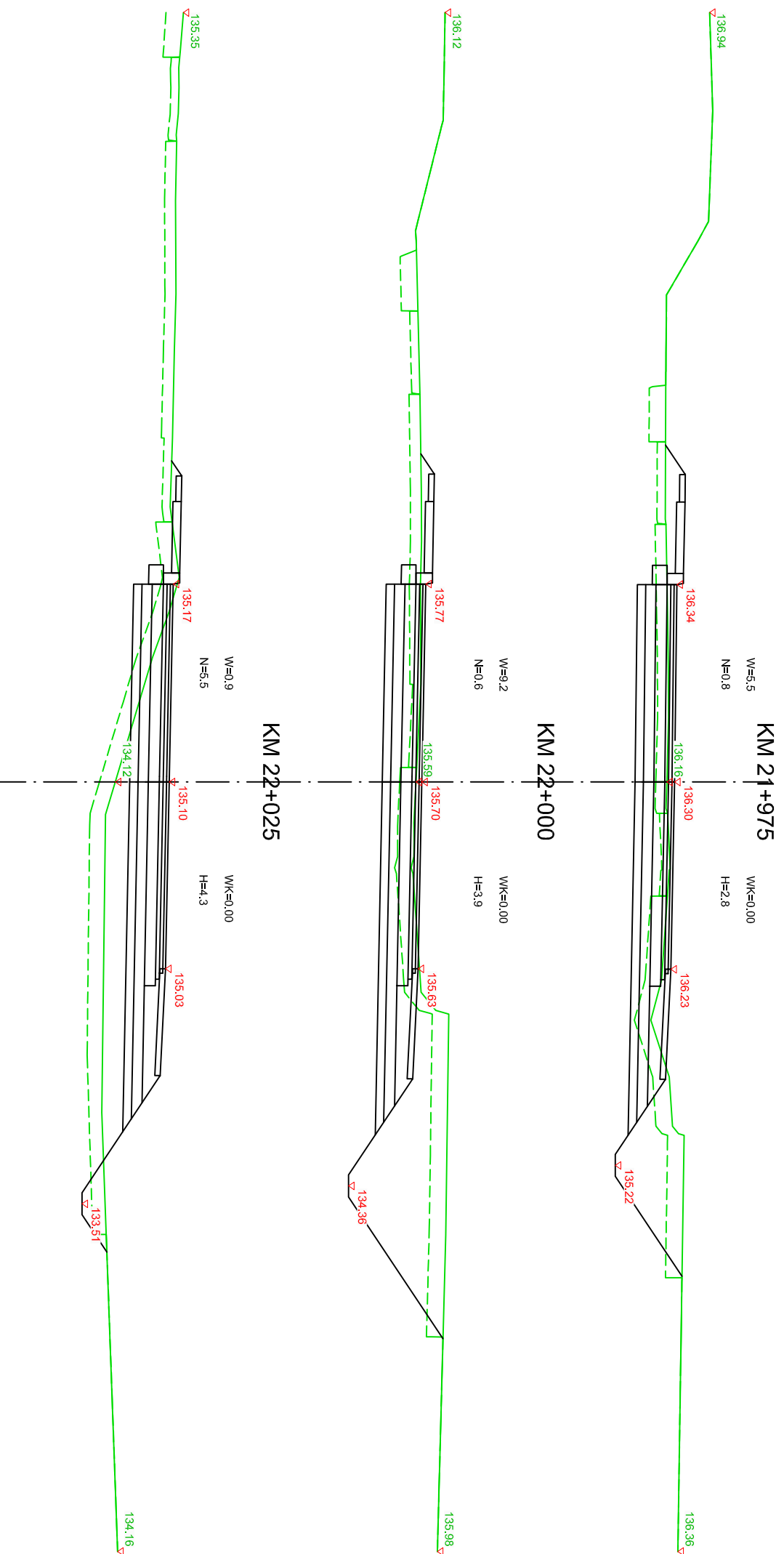



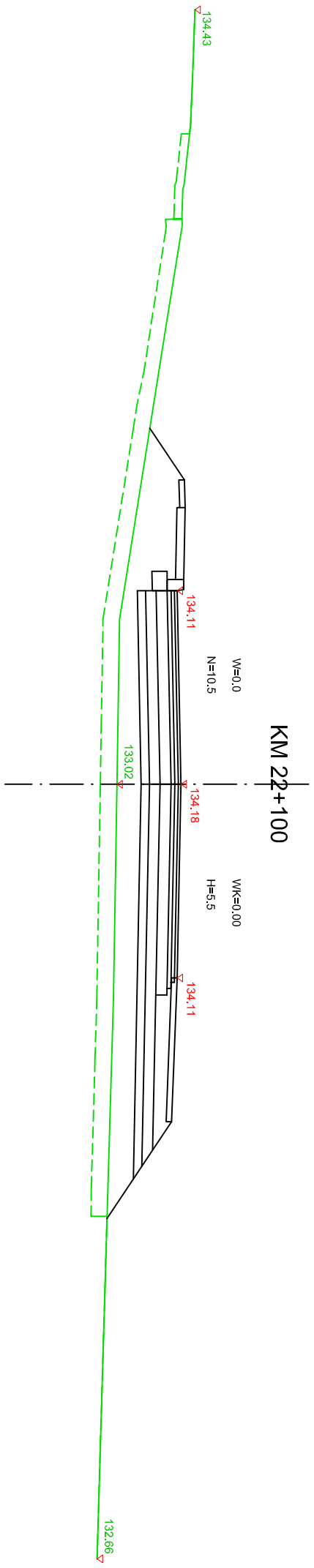
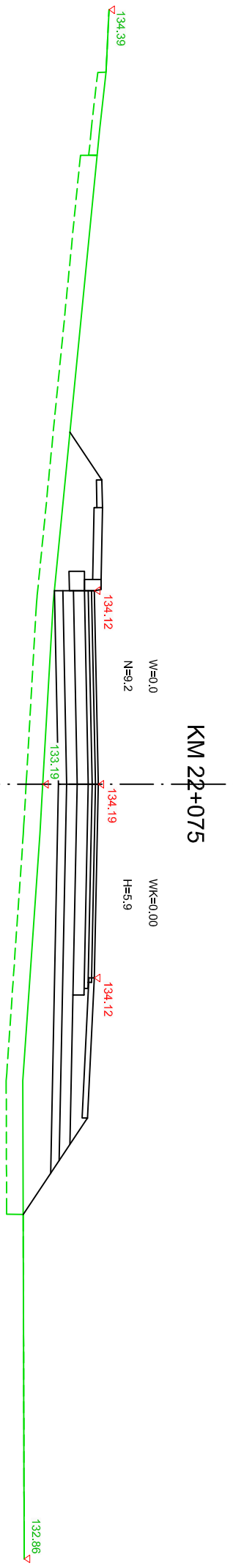
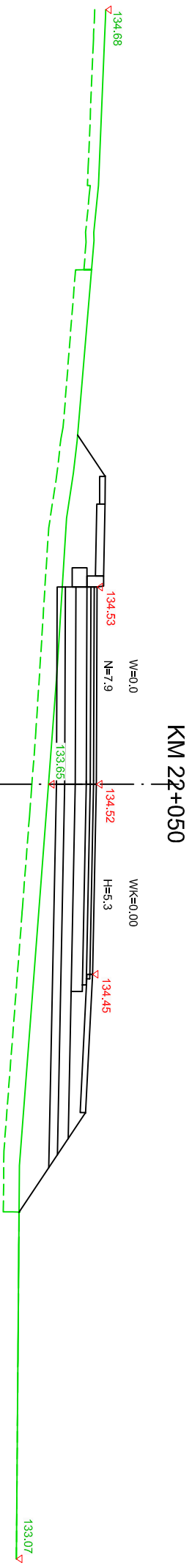

### KM 22+115

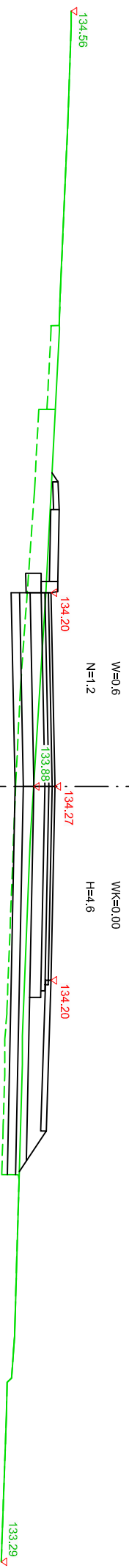

### KM 22+150

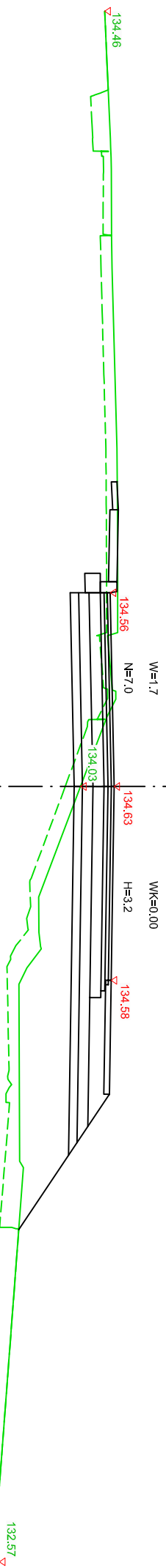

### KM 22+175

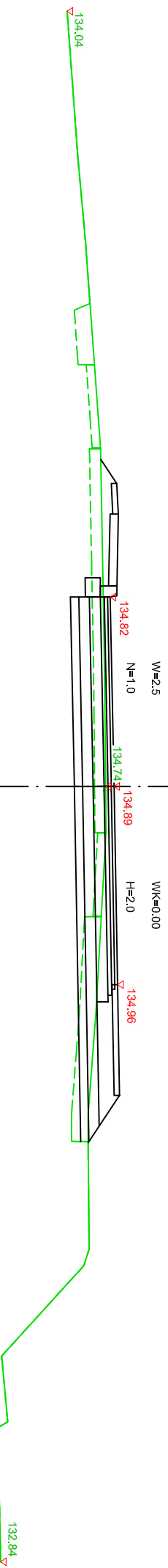

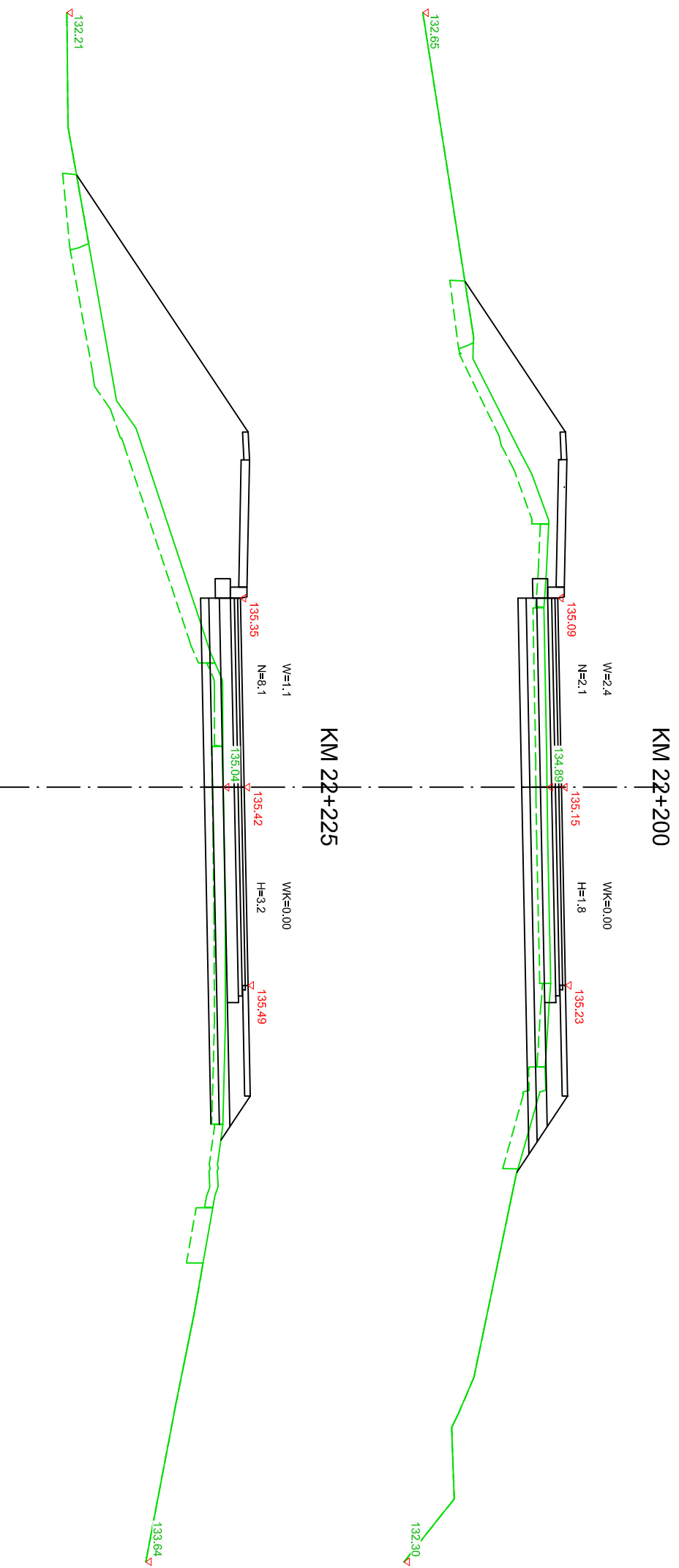

KM 22+260

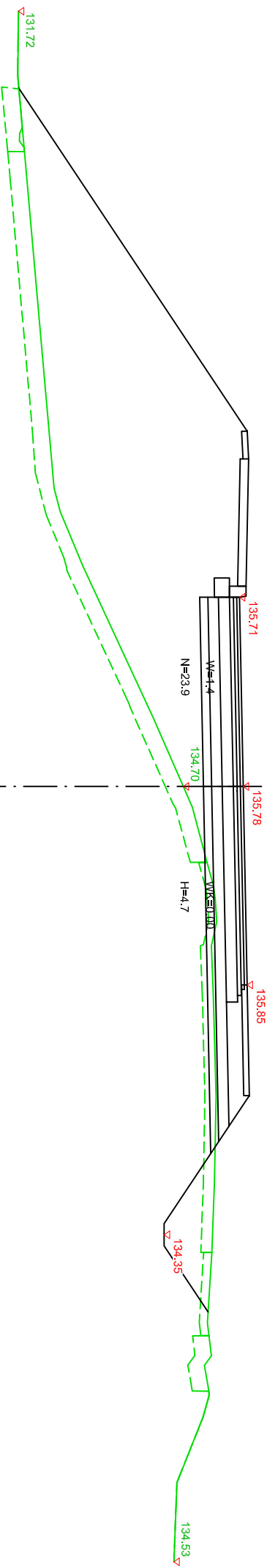

KM 22+275

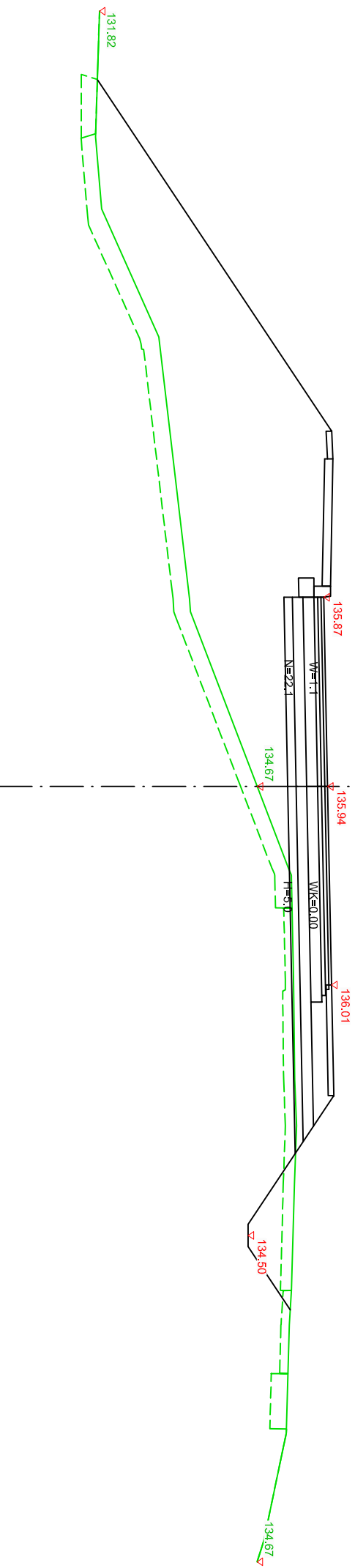

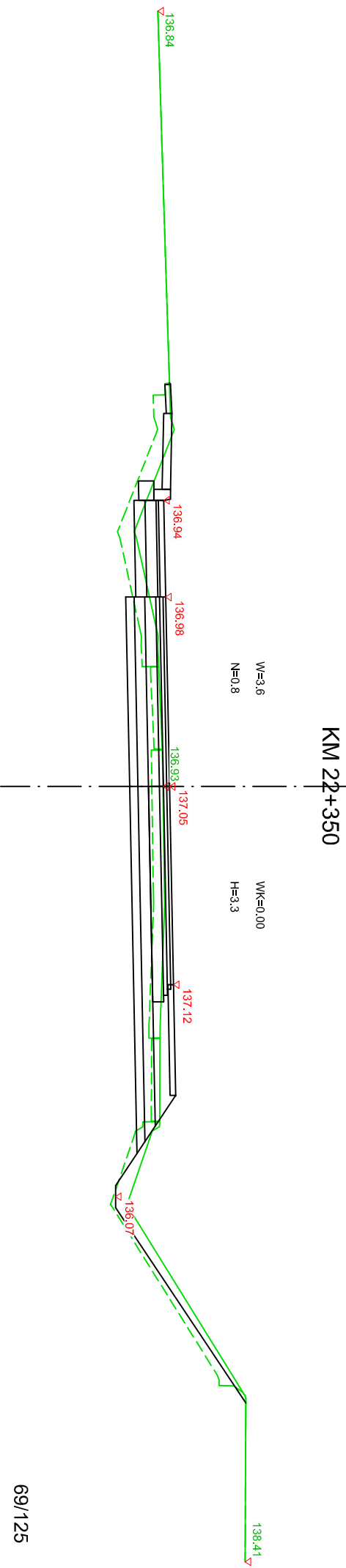
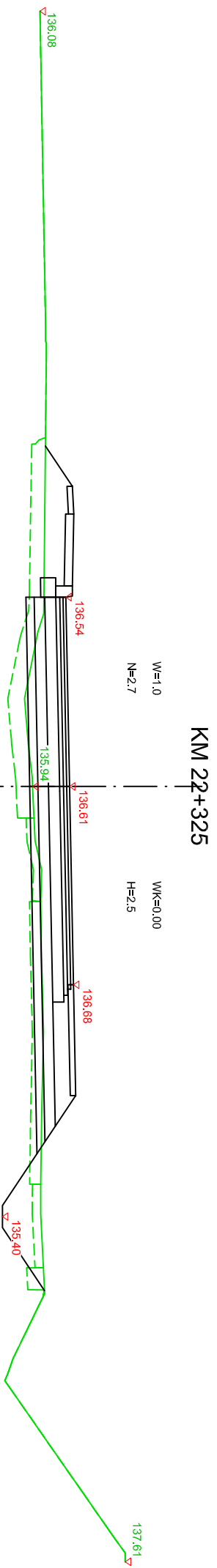
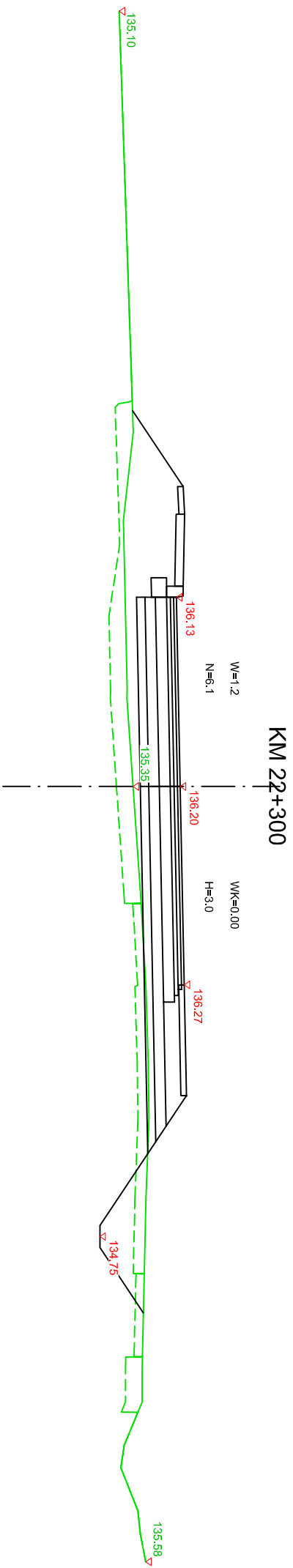

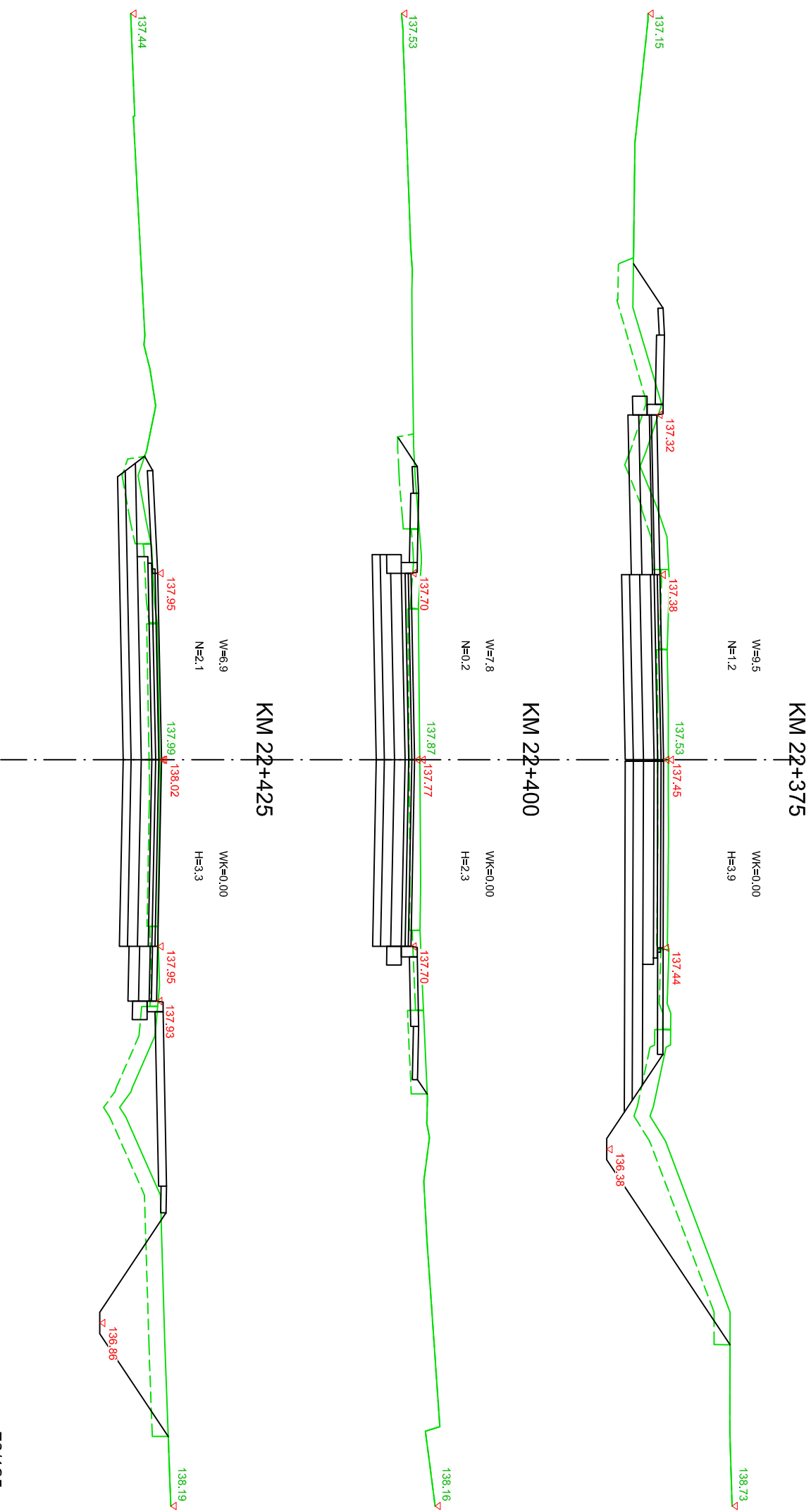

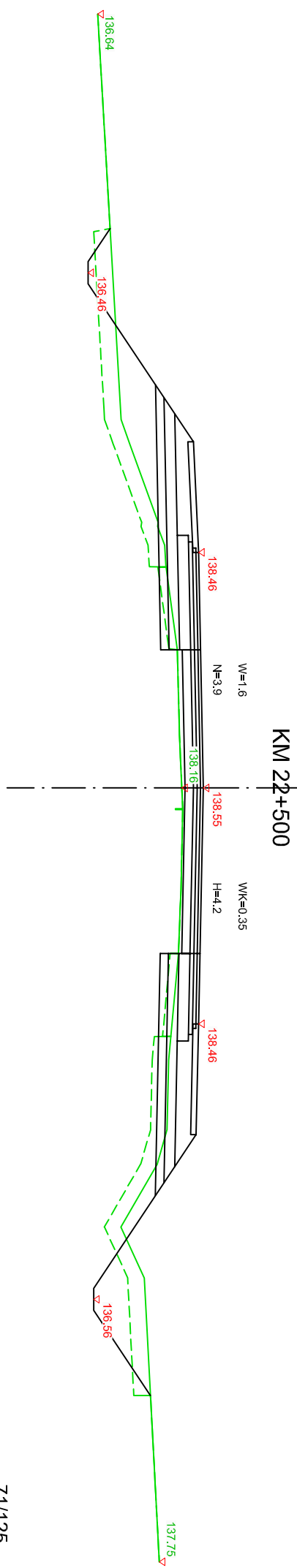
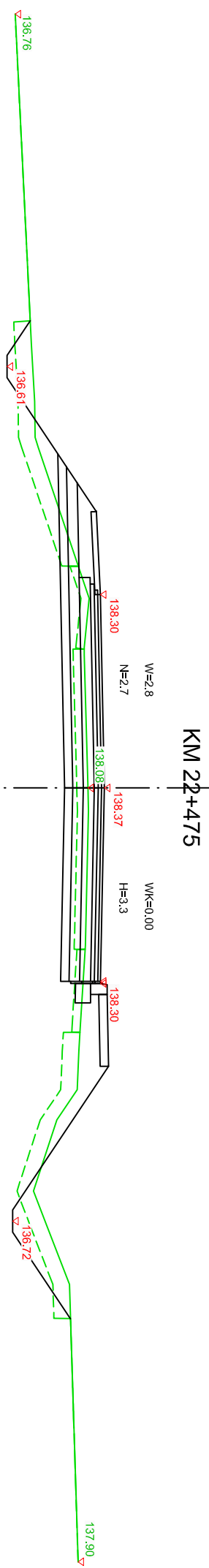
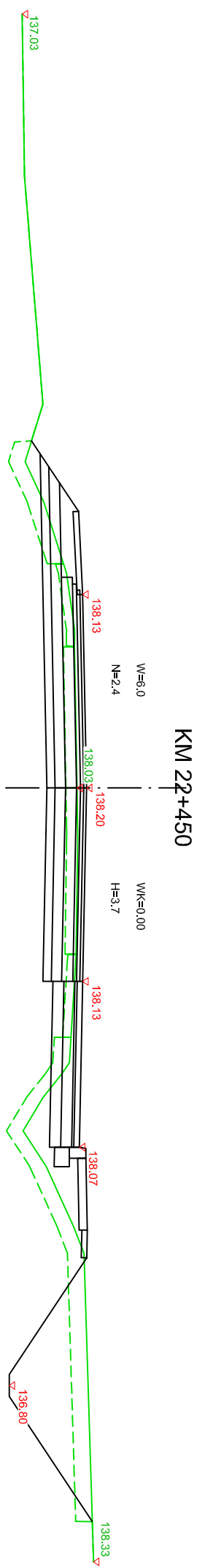

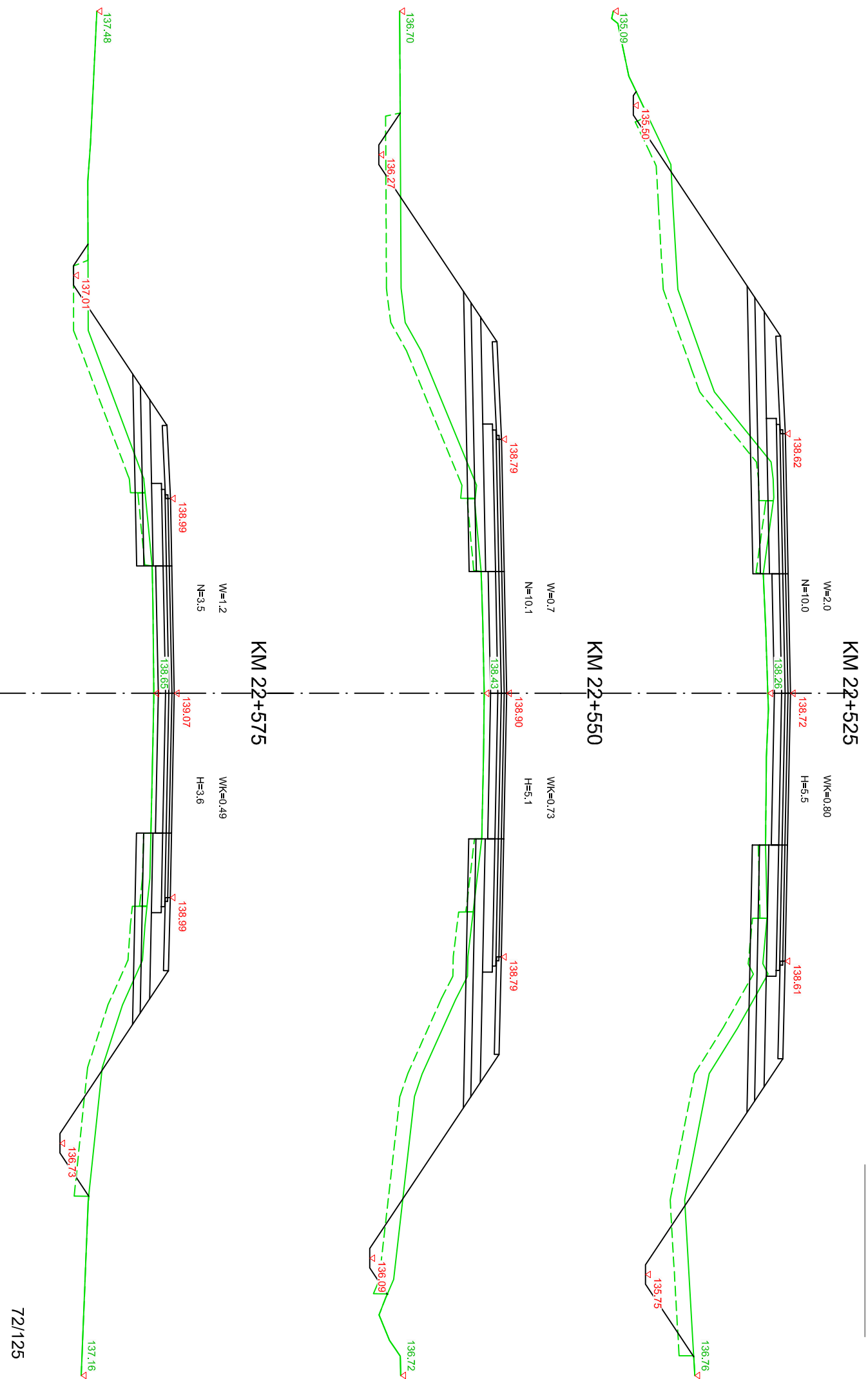



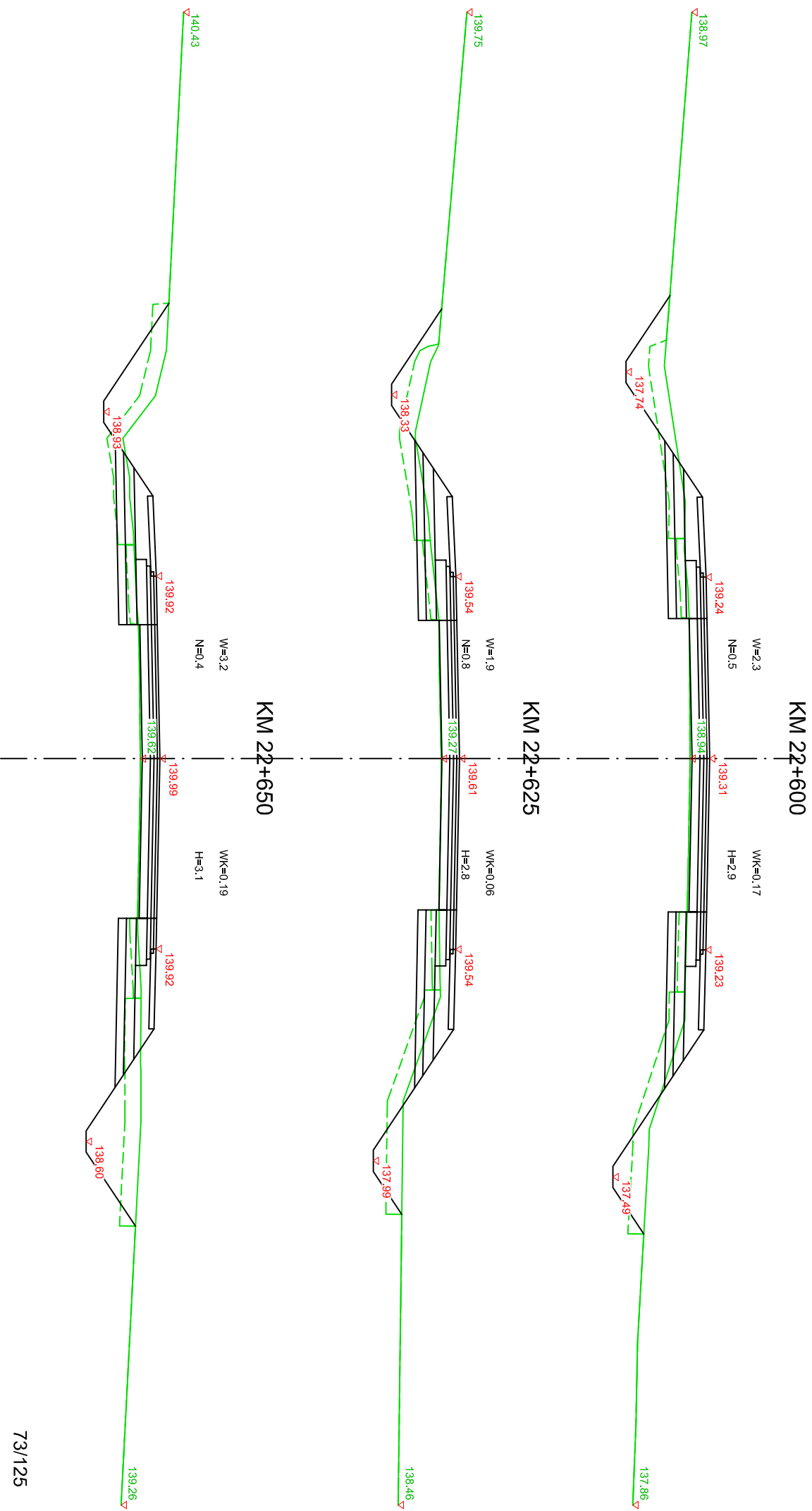

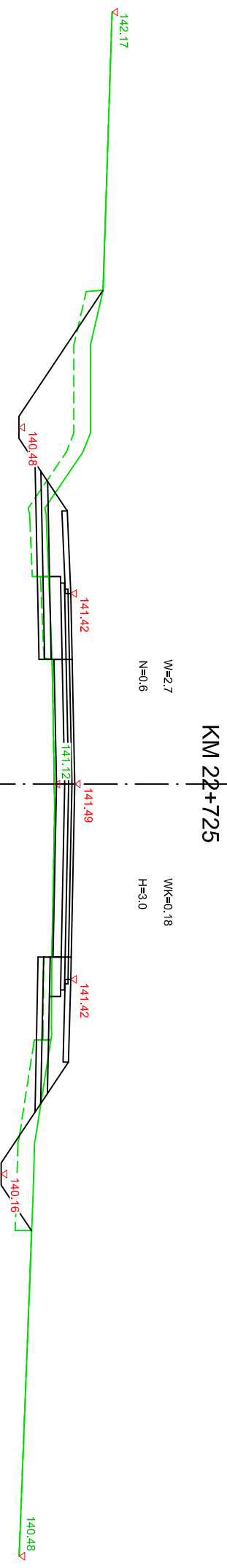
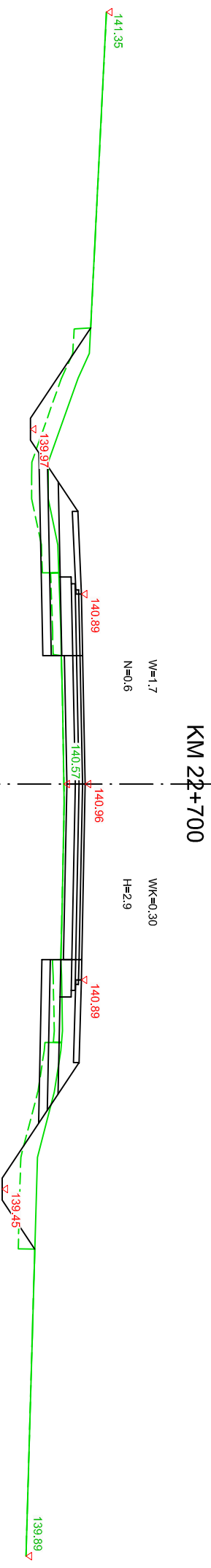
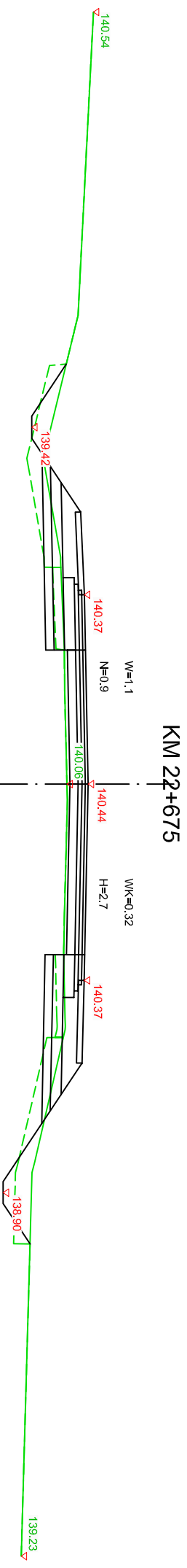

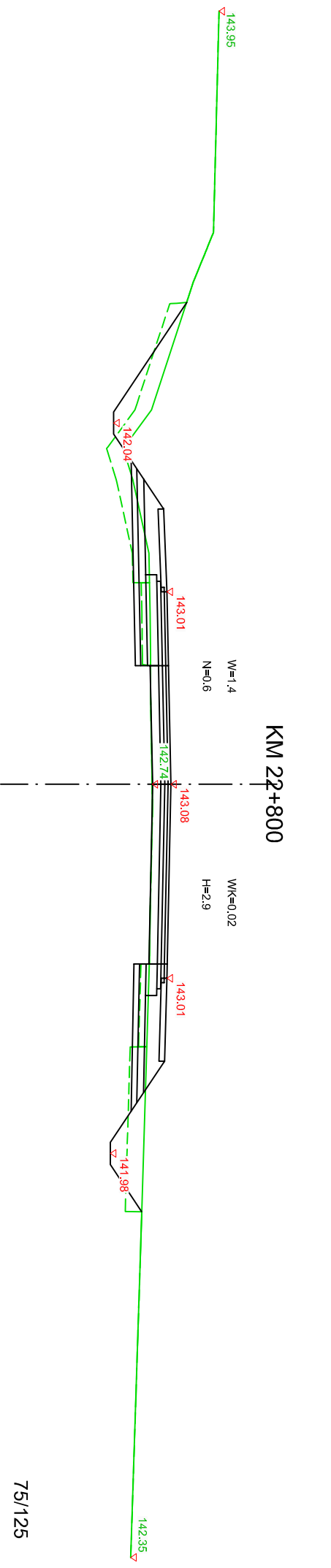
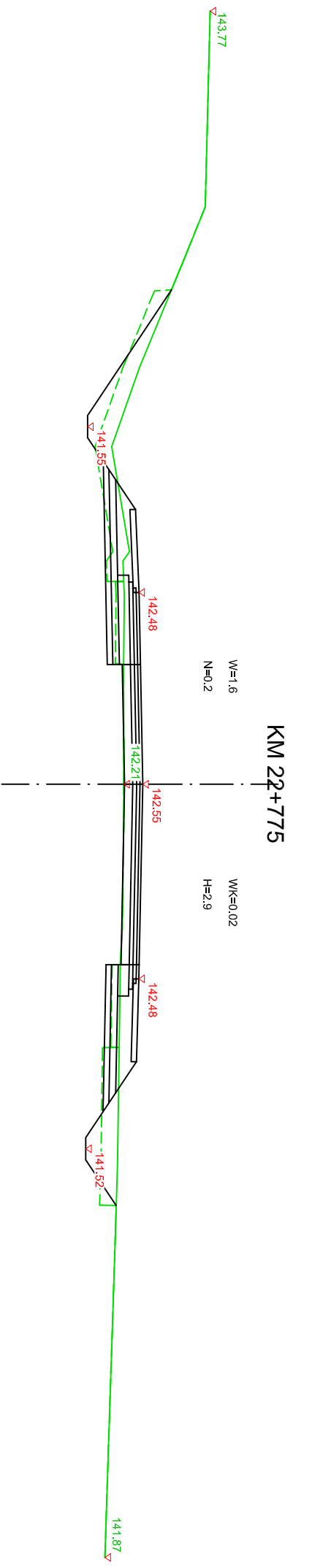
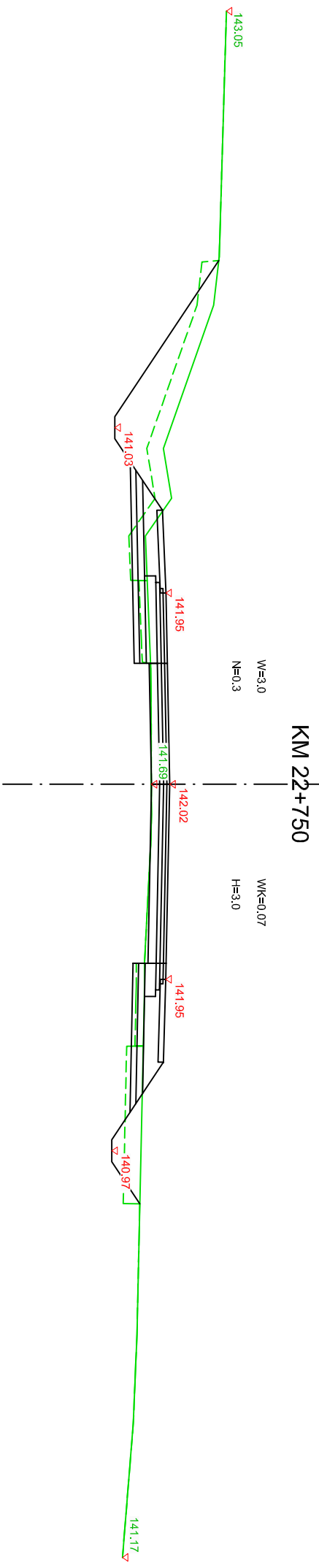

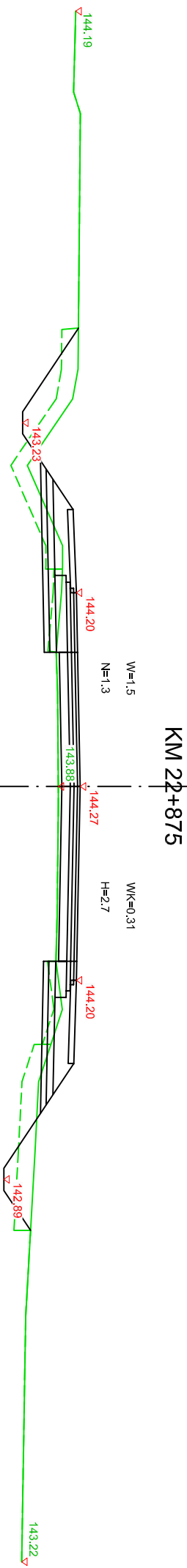
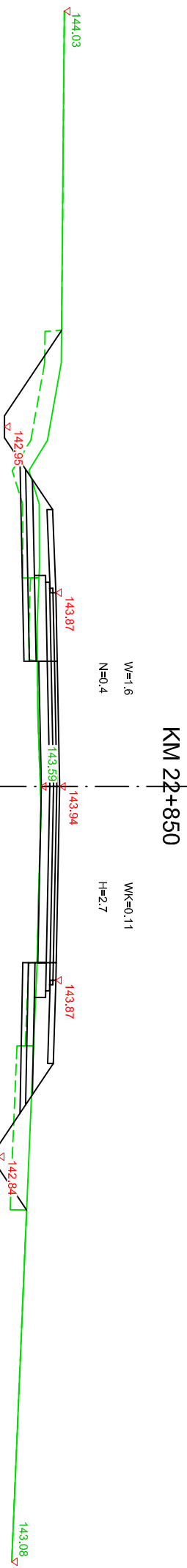
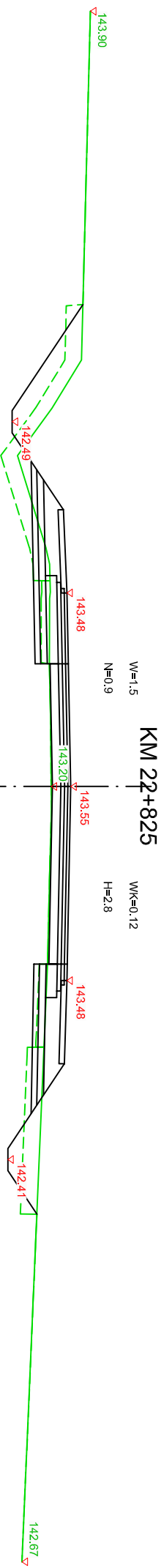

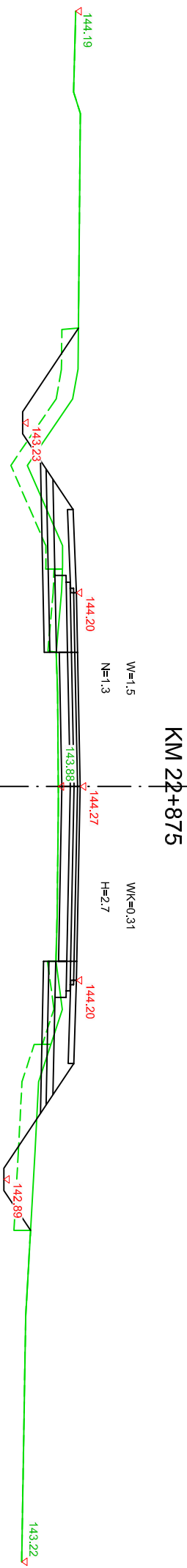
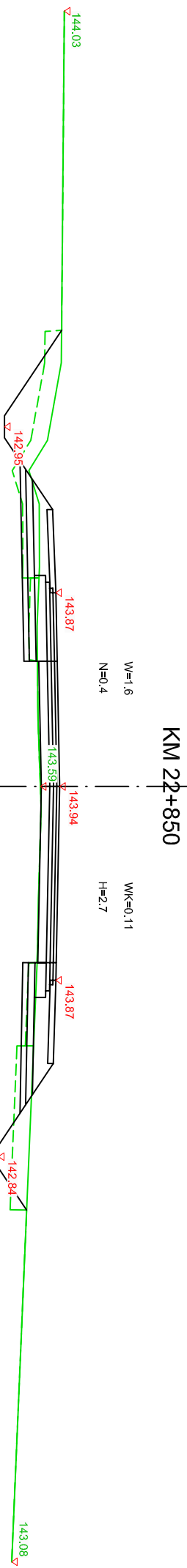
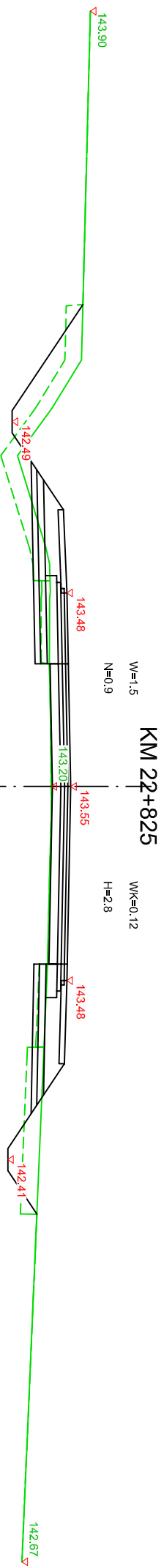

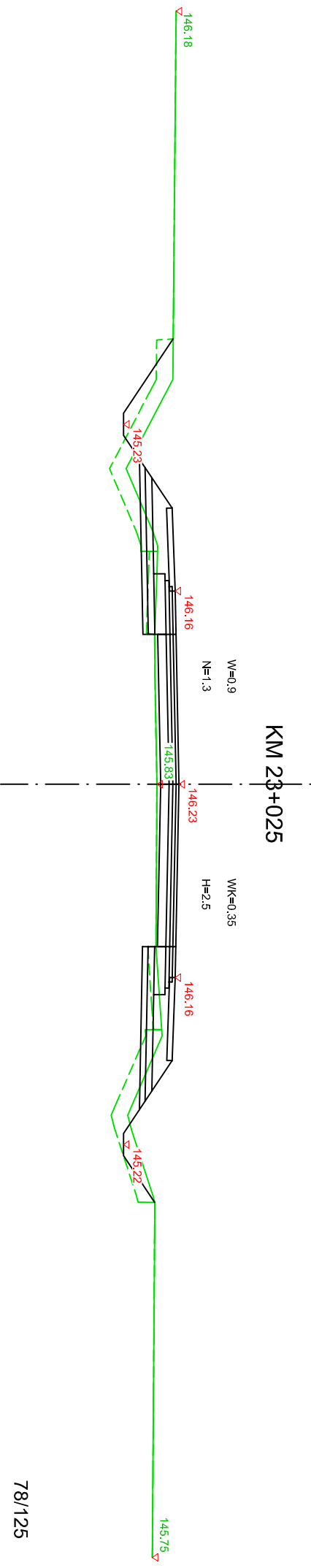
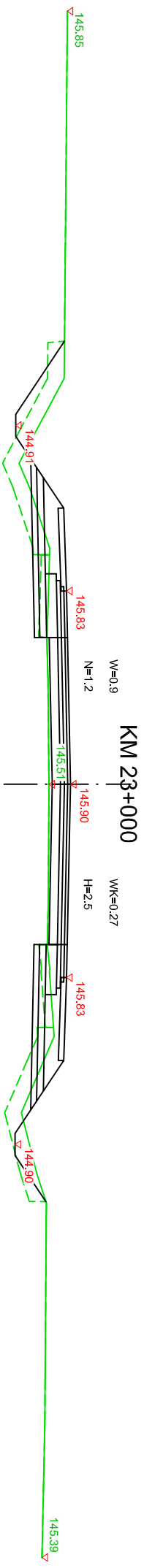
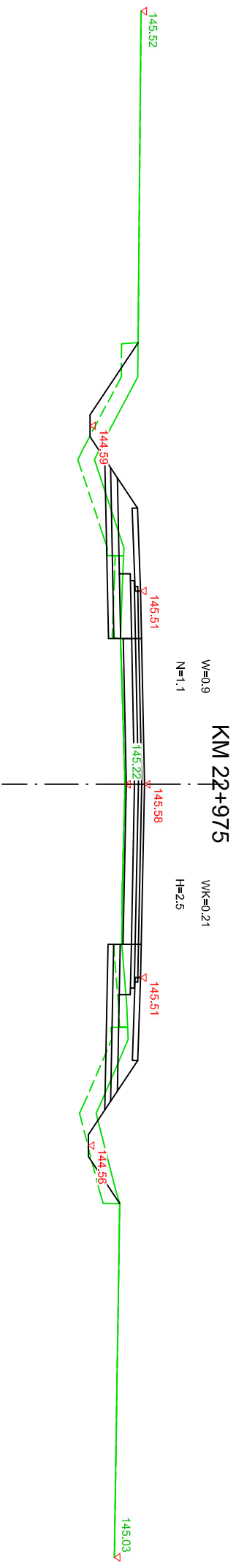

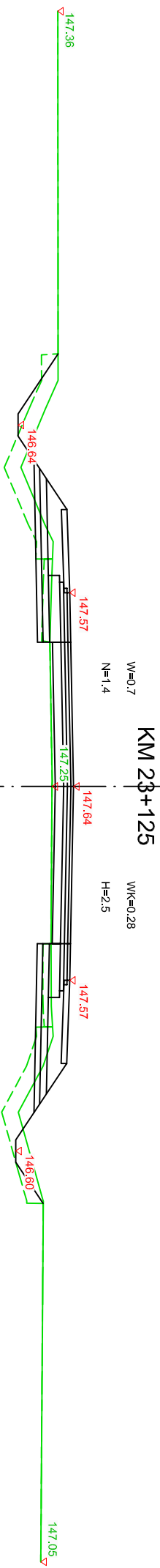
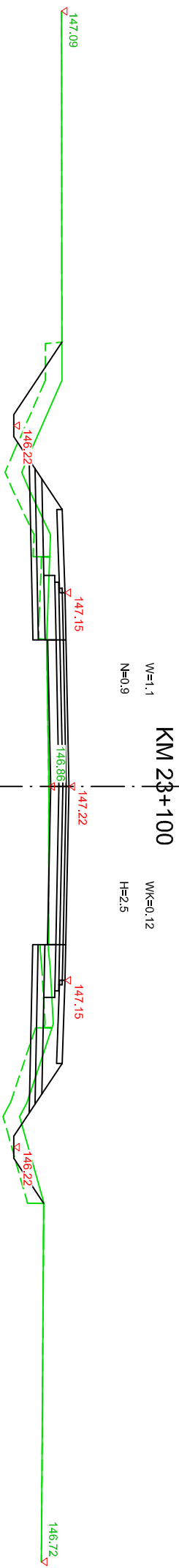
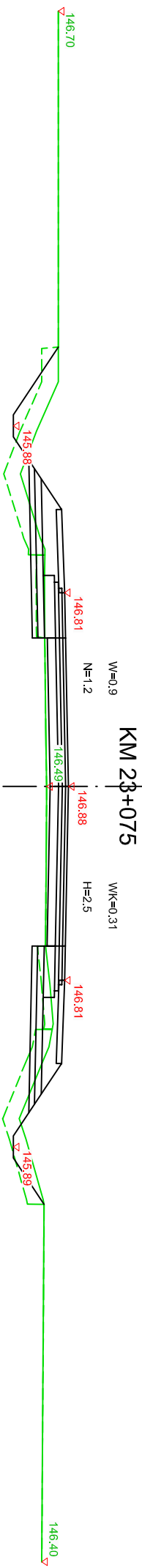
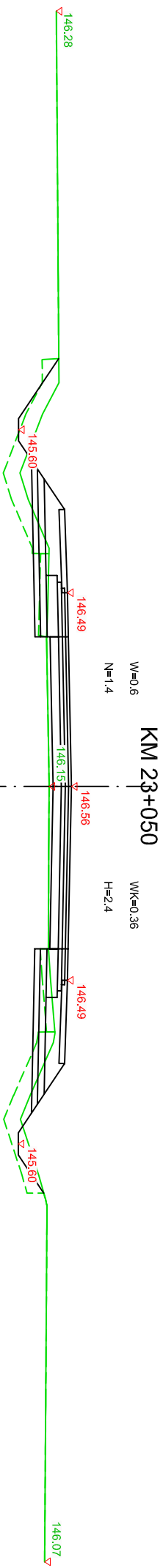

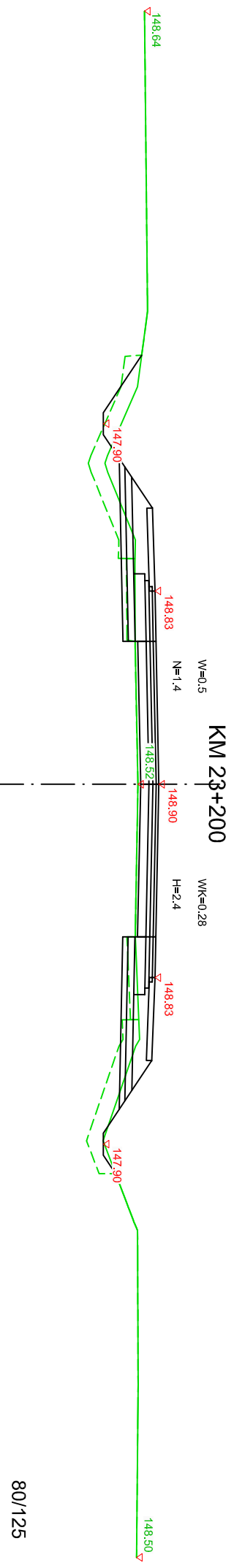
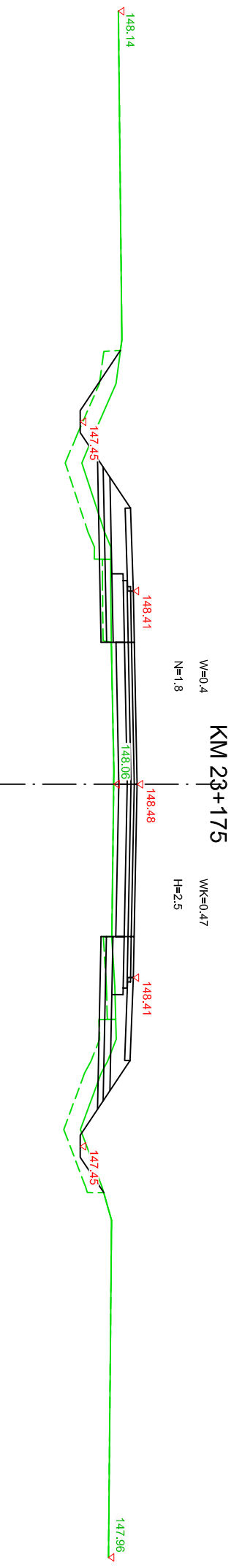
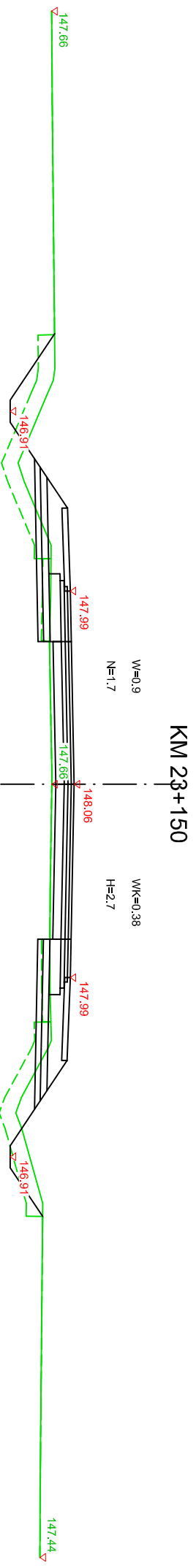



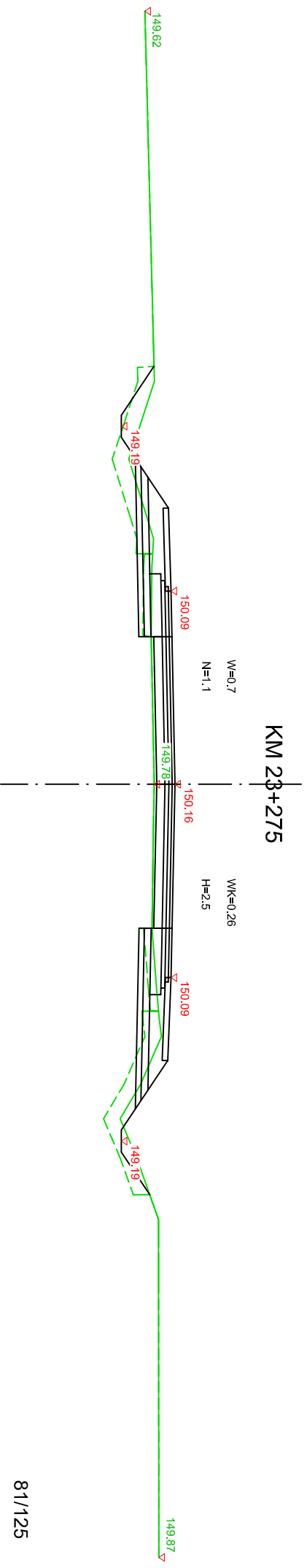
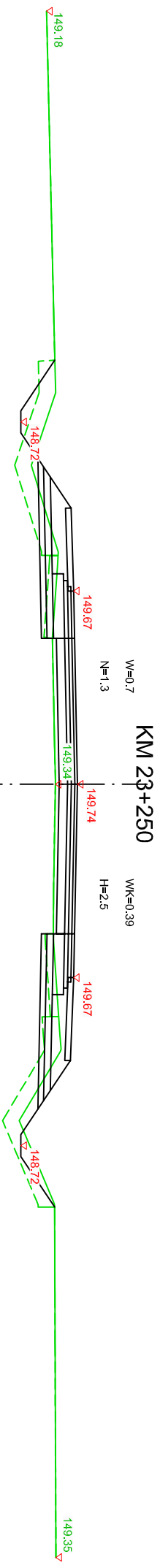
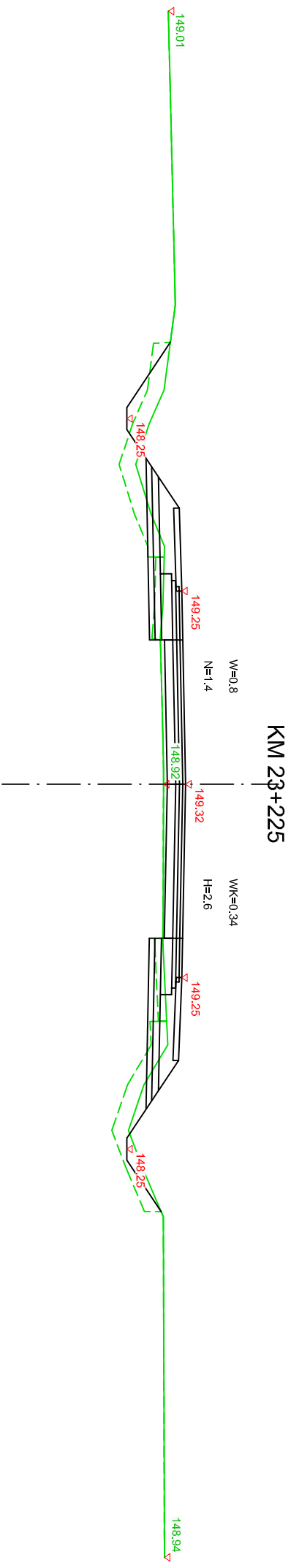

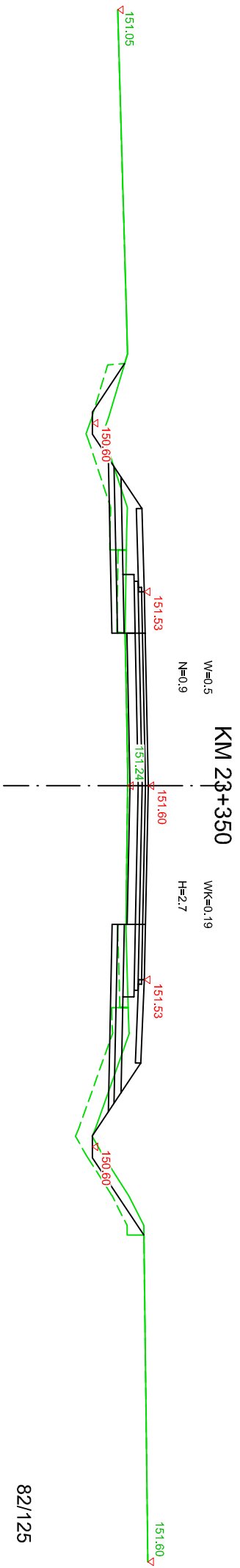
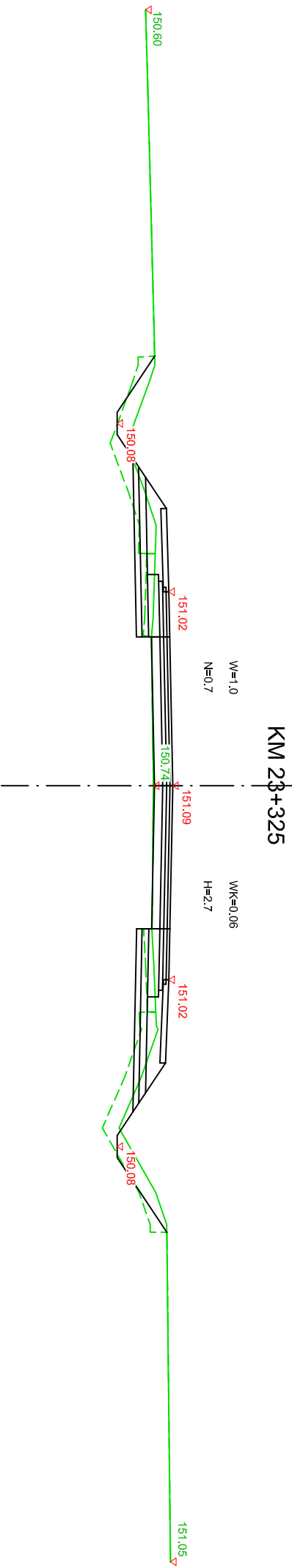
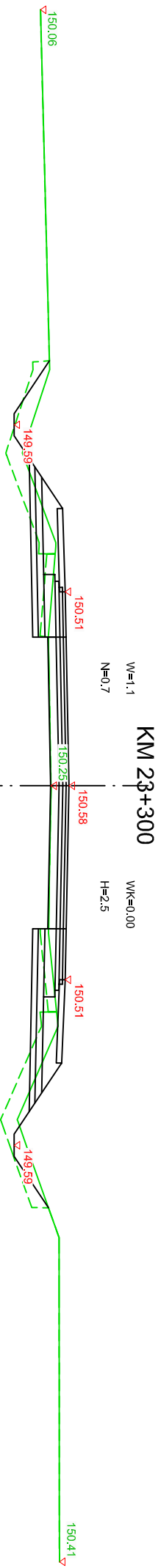

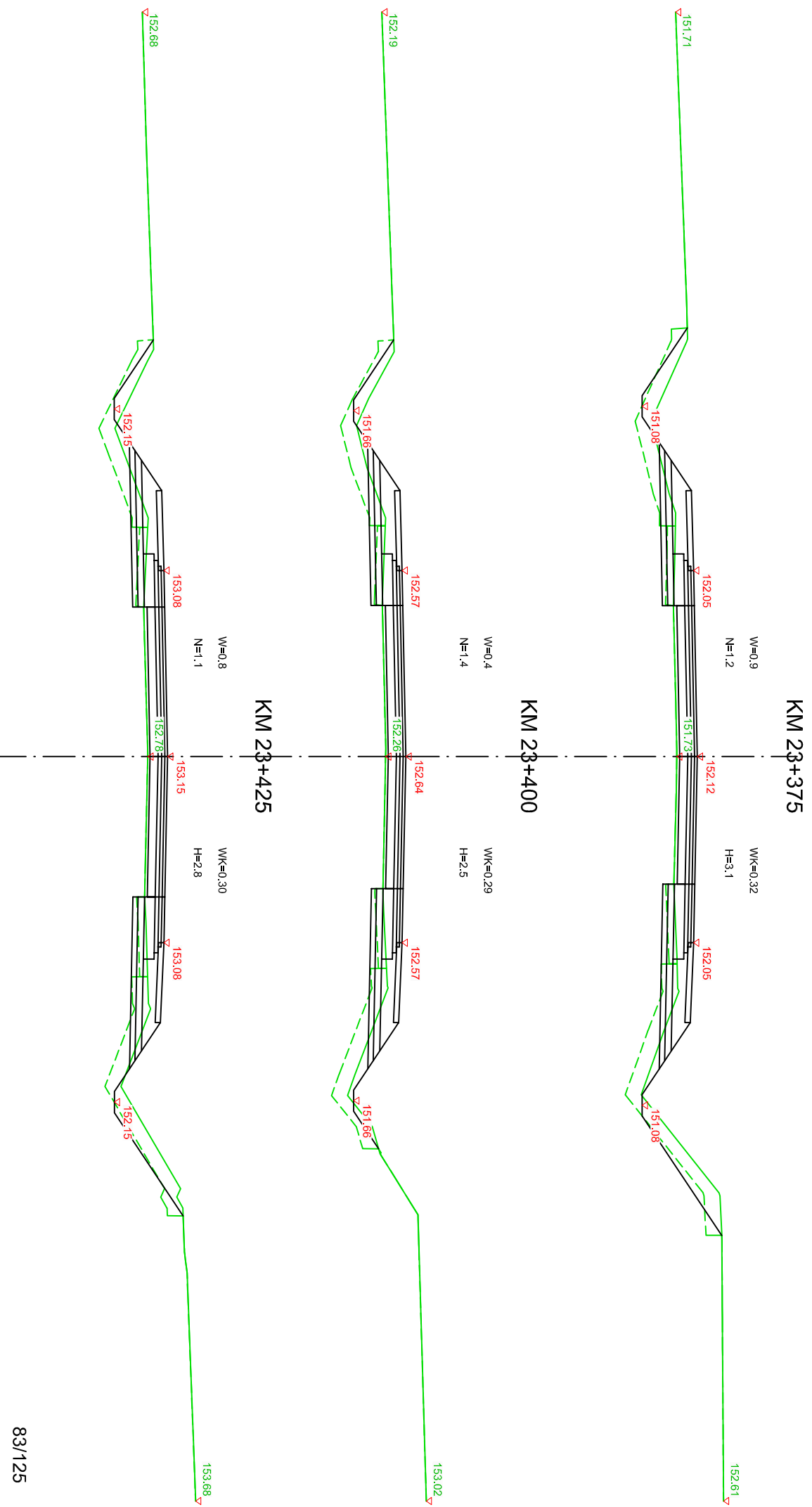

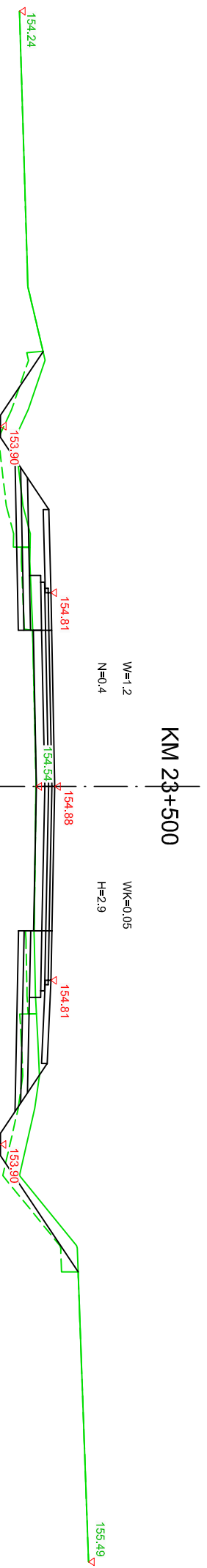
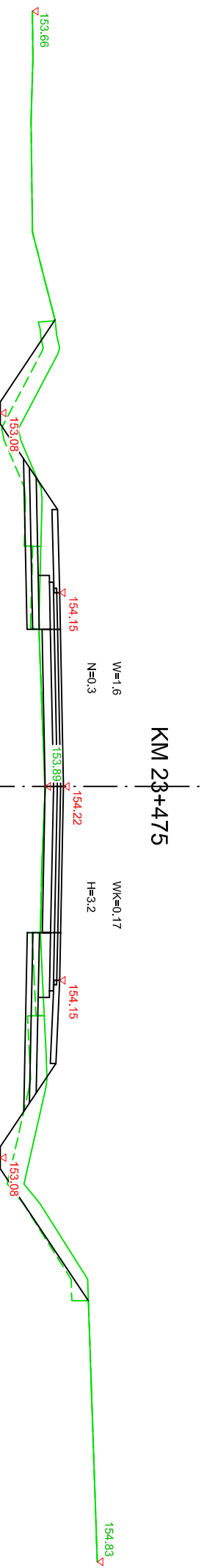
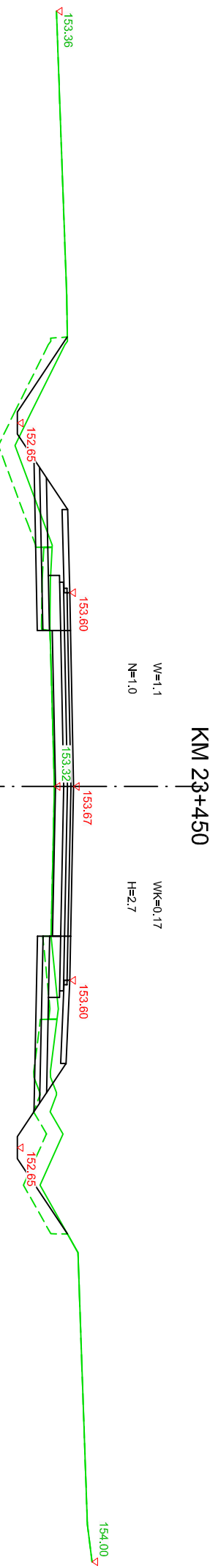

### KM 23+525

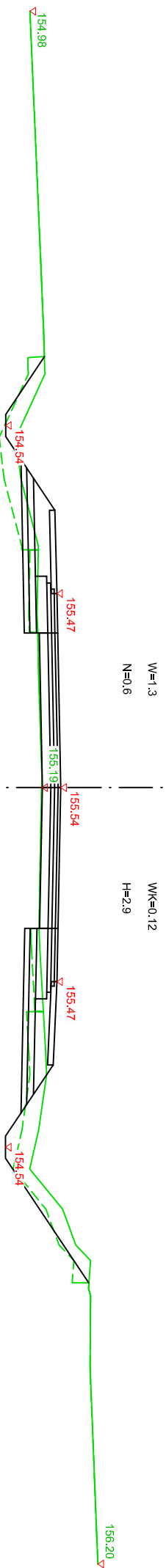

### KM 23+550



### KM 23+575

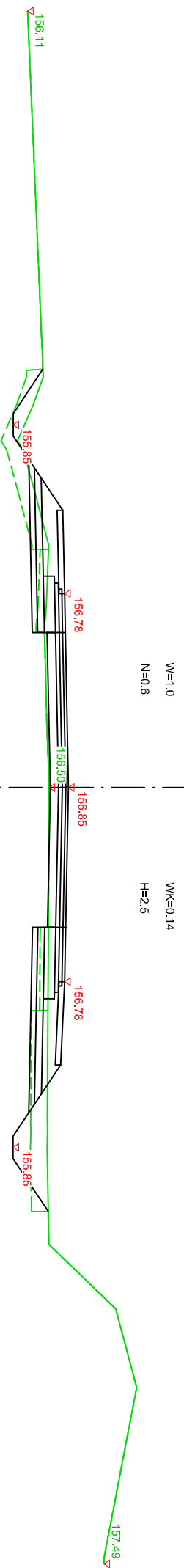

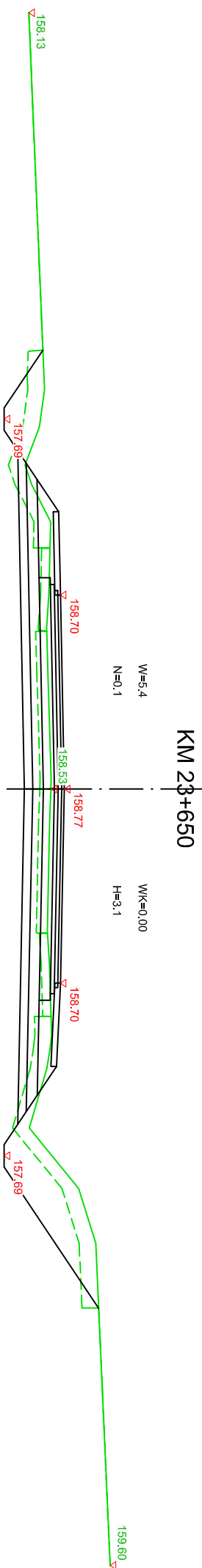
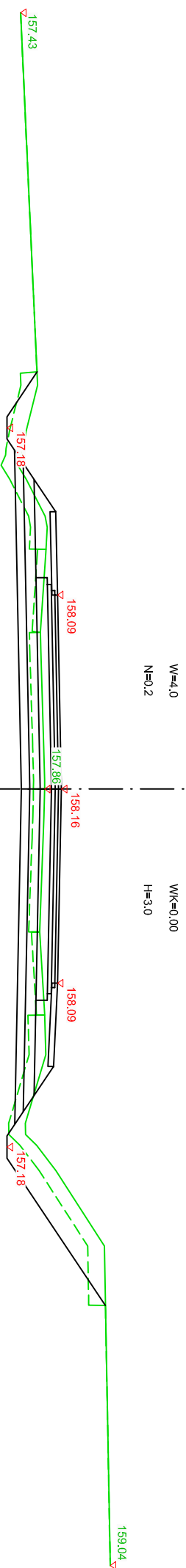
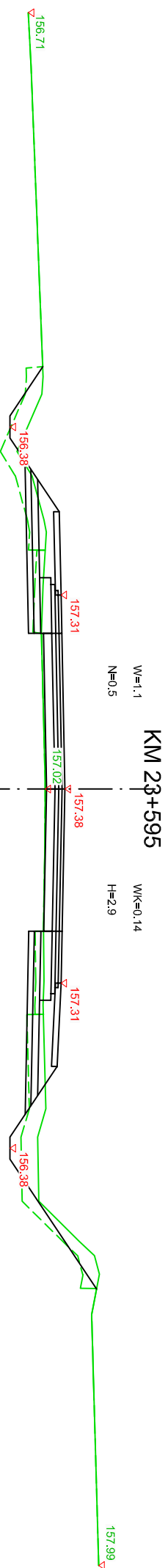

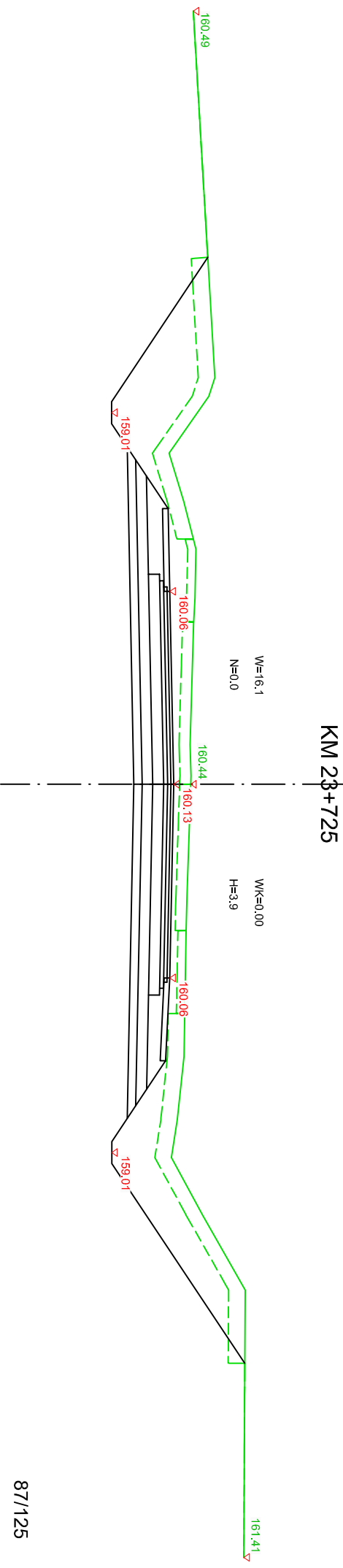
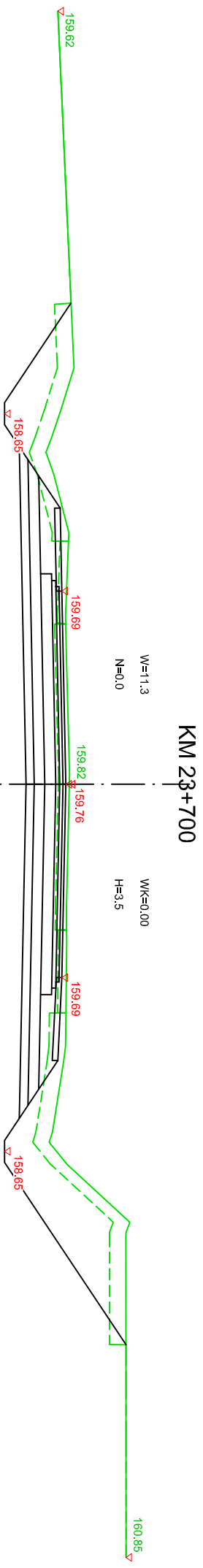
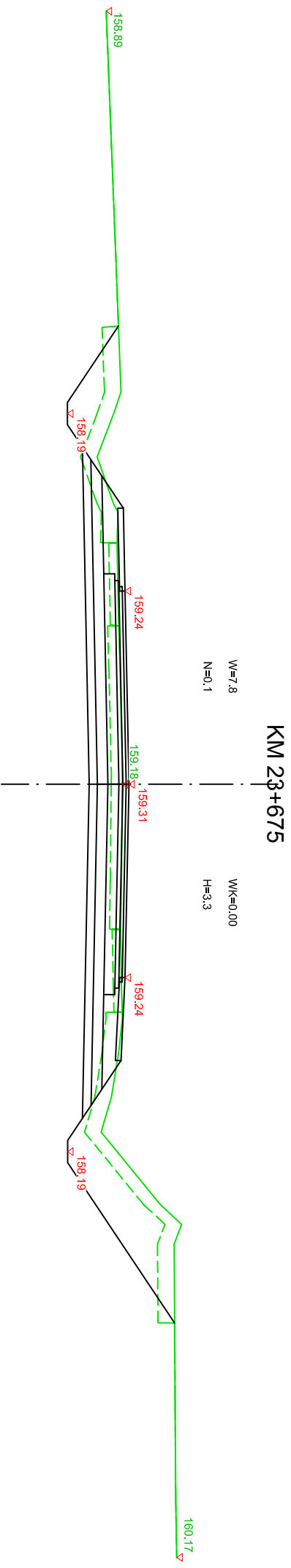

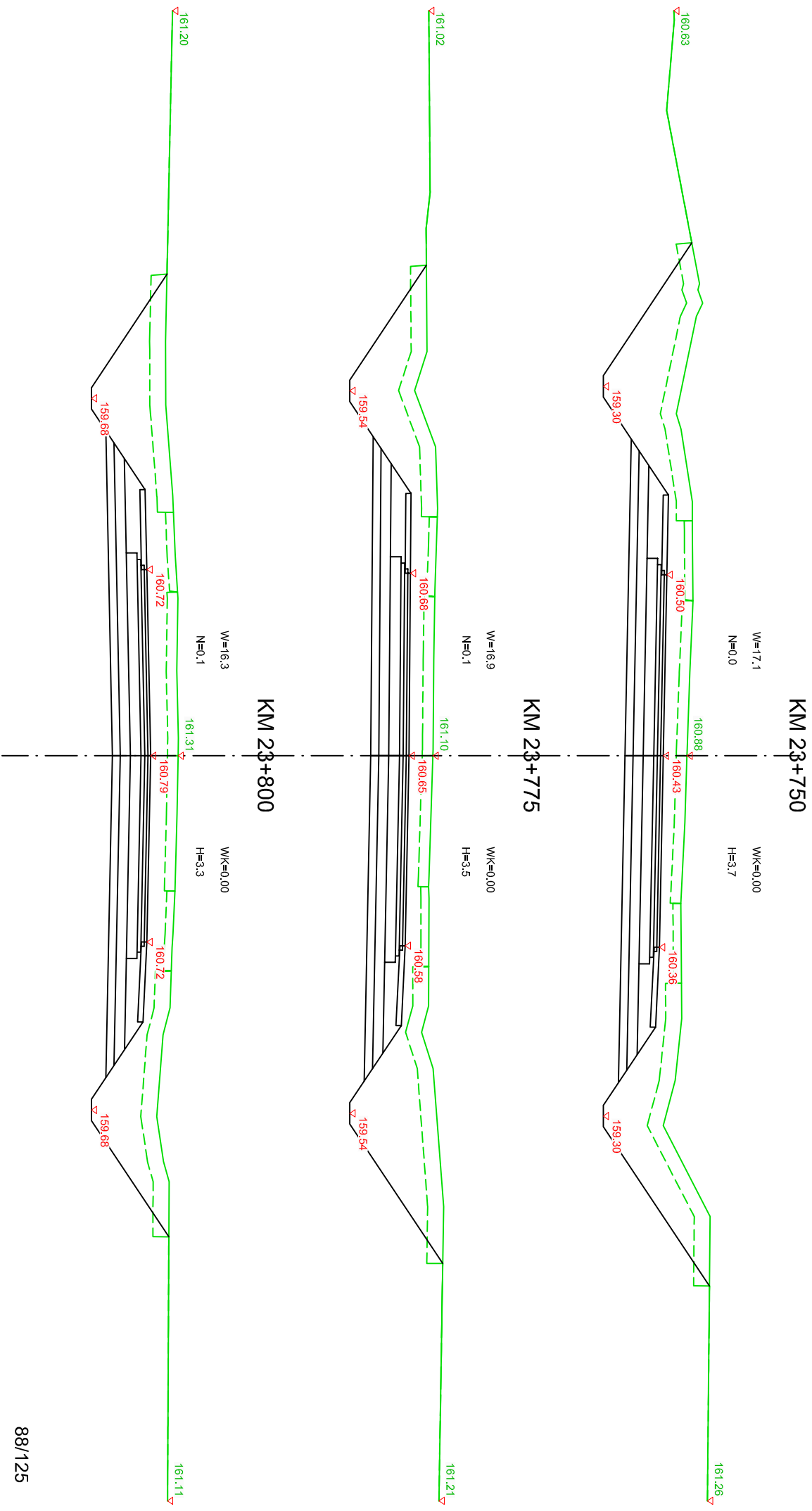



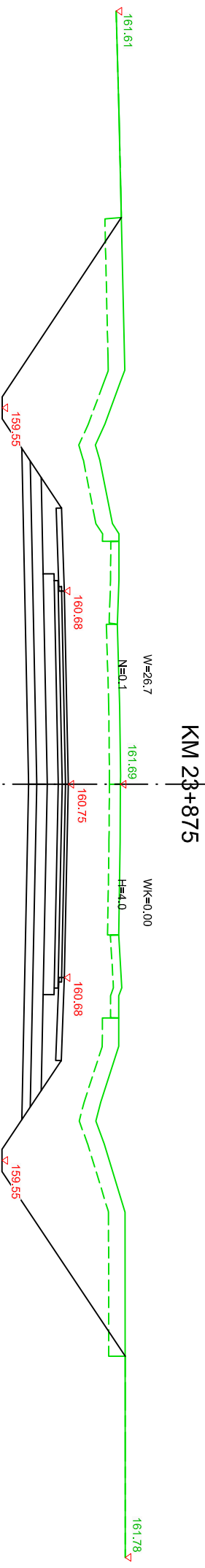
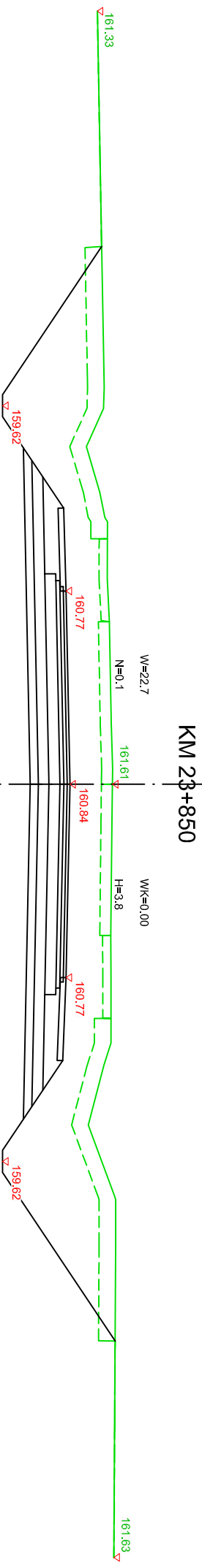
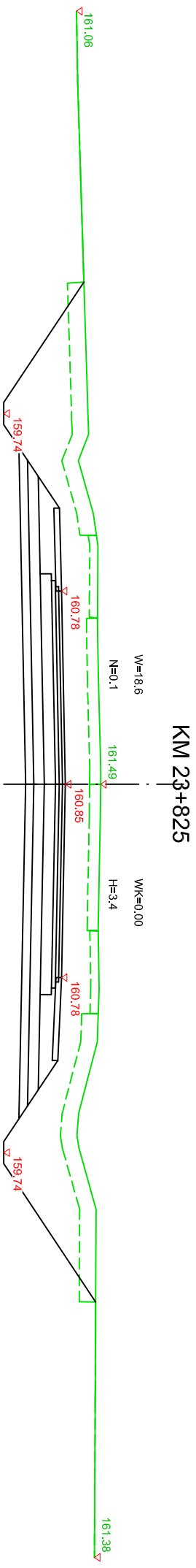

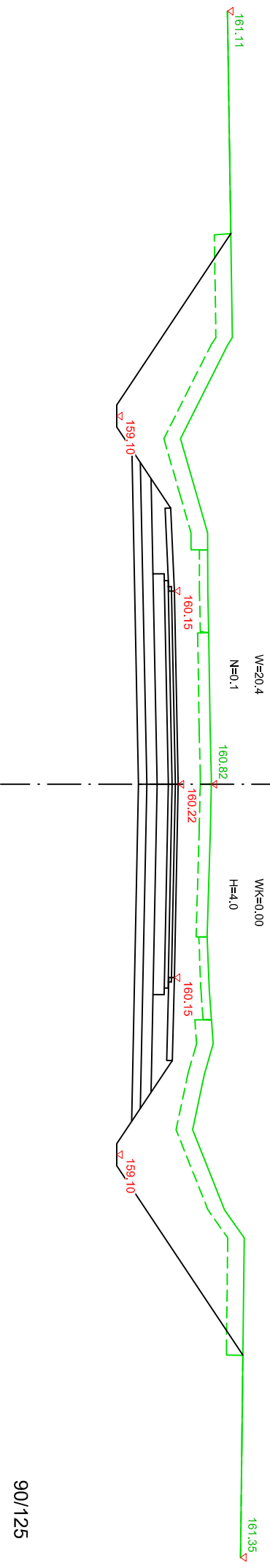
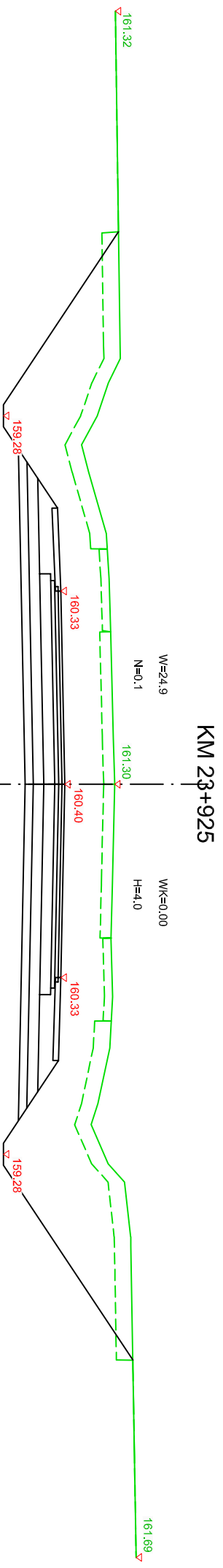
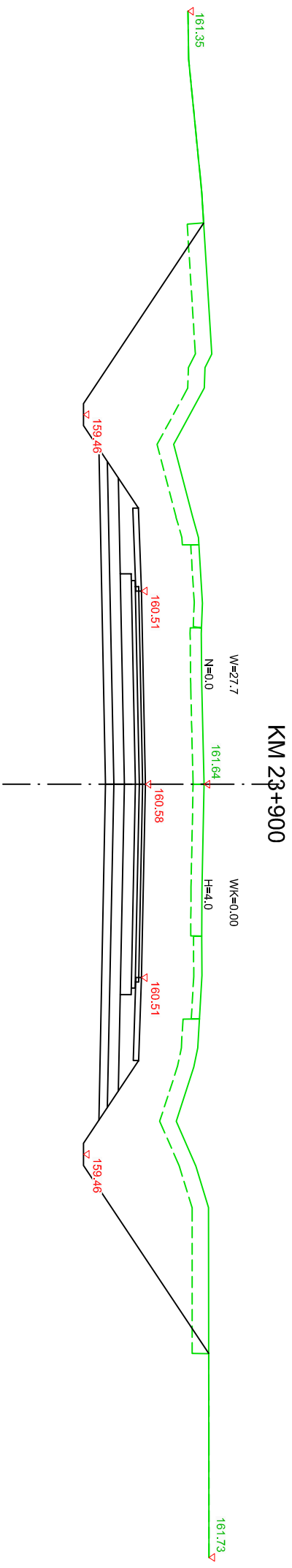

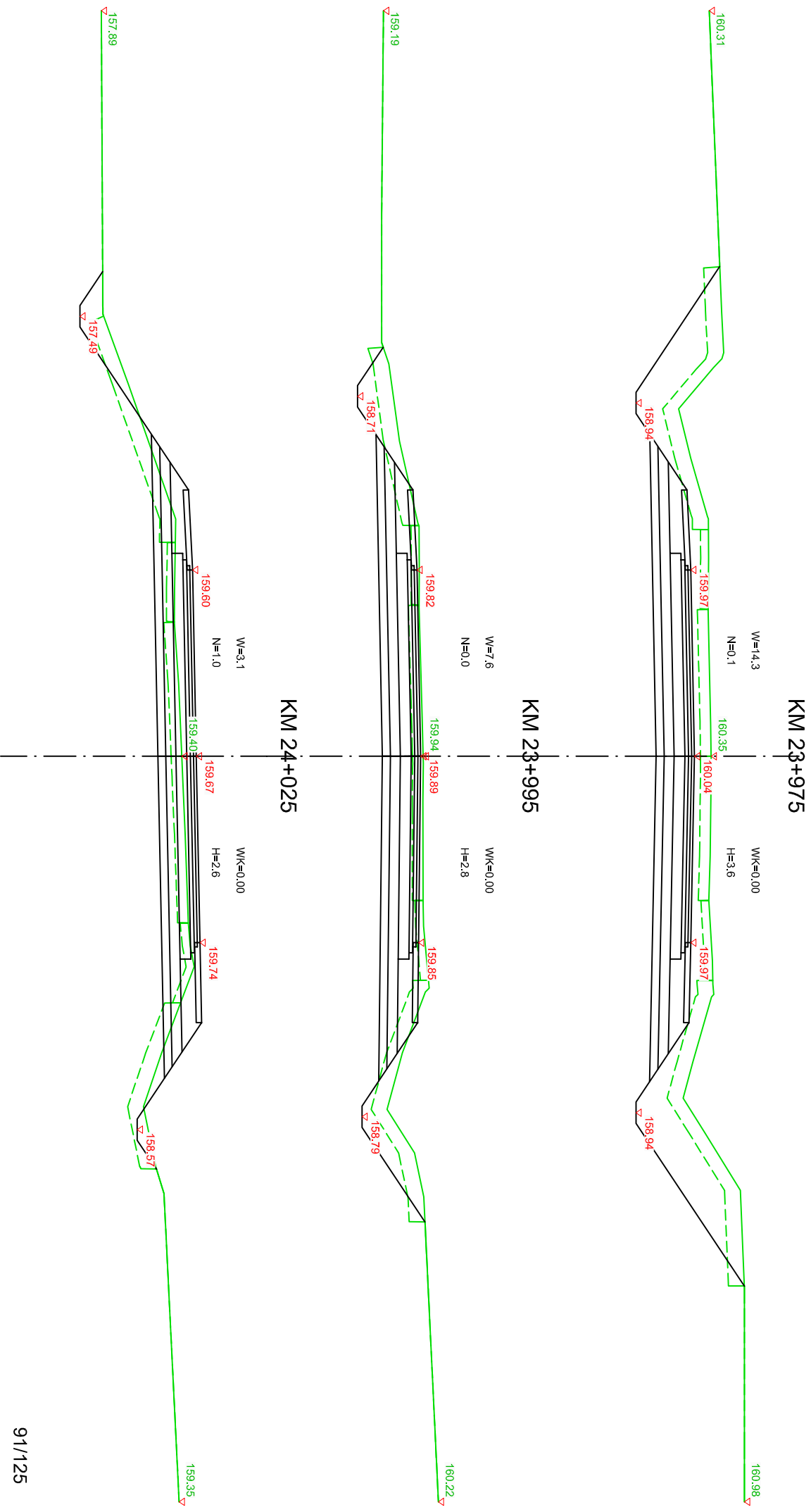

### KM 24+050

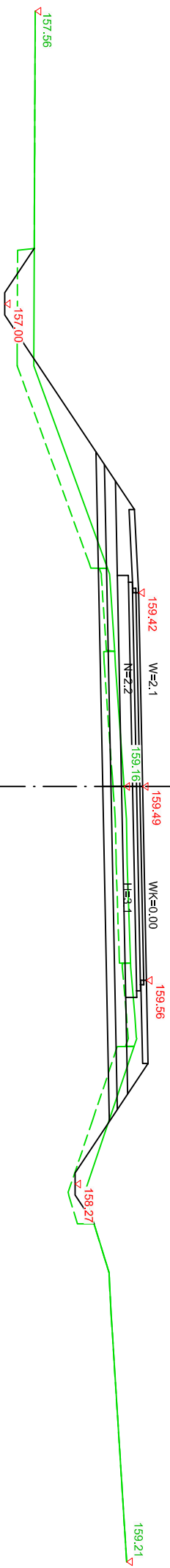

### KM 24+075

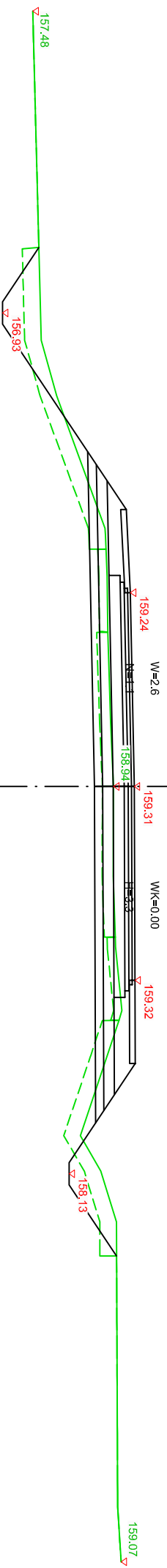

### KM 24+100

