

# PRZEKROJE POPRZECZNE DROGI WOJEWÓDZKIEJ NR 655 OD KM 100+740 DO KM 101+835

SKALA 1:10/100

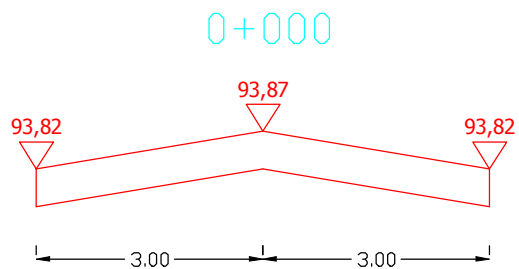

Pwyr.=0,0000 m<sup>2</sup>

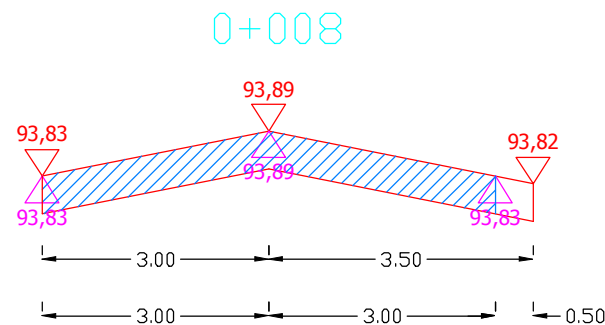

Pwyr.=0,0000 m<sup>2</sup>

Pfrez.=0,3000 m<sup>2</sup>

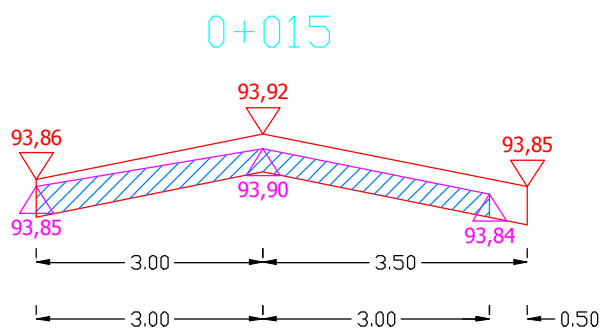

Pwyr.=0,0000 m<sup>2</sup>

Pfrez.=0,1950 m<sup>2</sup>

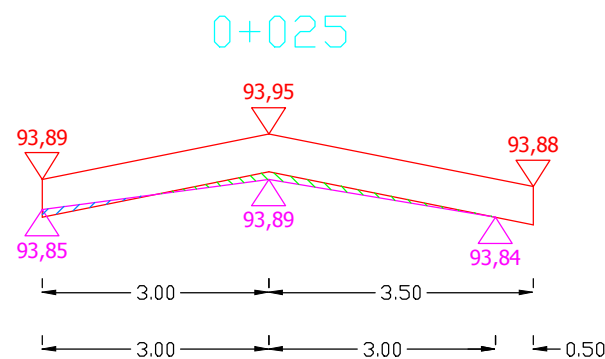

Pwyr.=0,0225 m<sup>2</sup>

Pfrez.=0,0075 m<sup>2</sup>

Sporządził:

# PRZEKROJE POPRZECZNE DROGI WOJEWÓDZKIEJ NR 655 OD KM 100+740 DO KM 101+835

SKALA 1:10/100

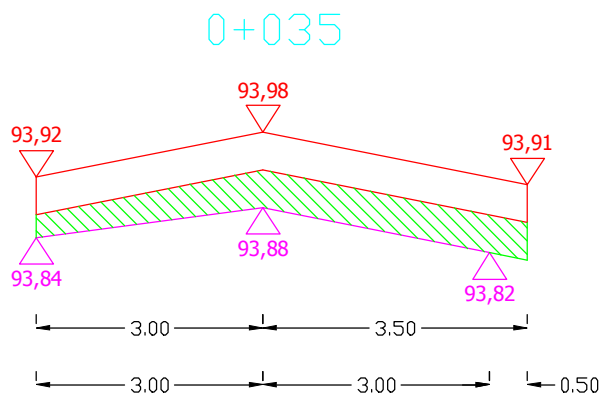

Pwyr.=0,2950 m<sup>2</sup>

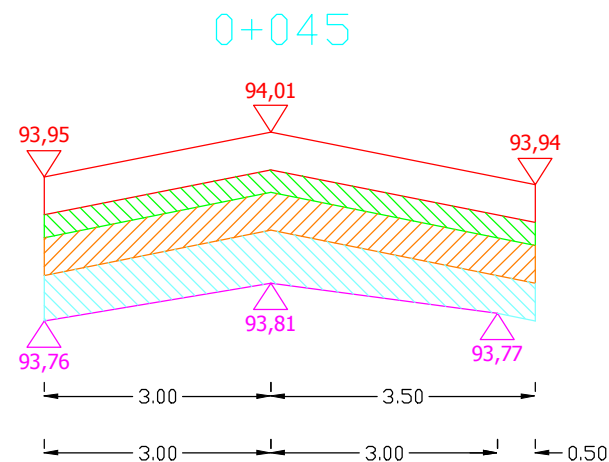

Pwyr.=0,1950 m<sup>2</sup>

Pwiąż.=0,3250 m<sup>2</sup>

Pkrusz.=0,4000 m<sup>2</sup>

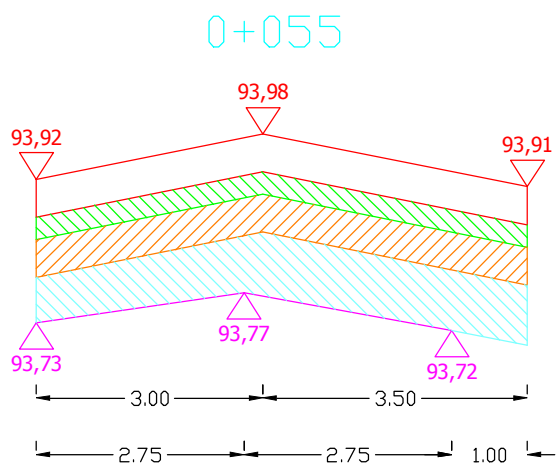

Pwyr.=0,1950 m<sup>2</sup>

Pwiąż.=0,3250 m<sup>2</sup>

Pkrusz.=0,4913 m<sup>2</sup>

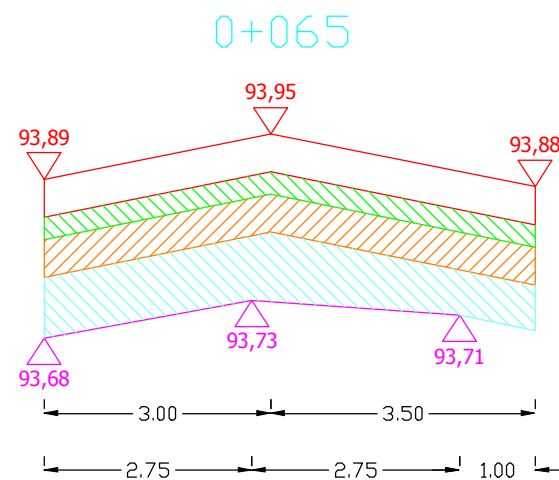

Pwyr.=0,1950 m<sup>2</sup>

Pwiąż.=0,3250 m<sup>2</sup>

Pkrusz.=0,4988 m<sup>2</sup>

Sporządził:

# PRZEKROJE POPRZECZNE DROGI WOJEWÓDZKIEJ NR 655 OD KM 100+740 DO KM 101+835

SKALA 1:10/100

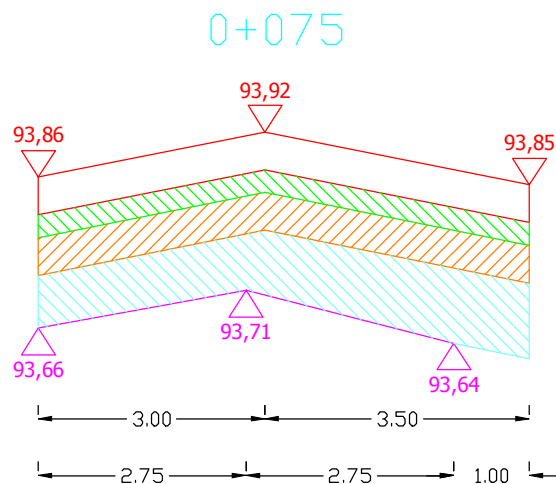

Pwyr.=0,1950 m<sup>2</sup>

Pwiąż.=0,3250 m<sup>2</sup>

Pkrusz.=0,5525 m<sup>2</sup>

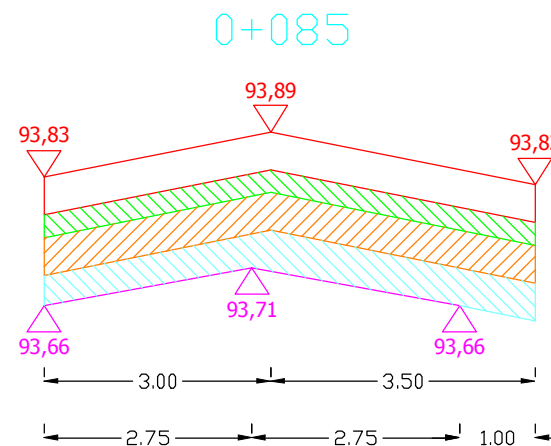

Pwyr.=0,1950 m<sup>2</sup>

Pwiąż.=0,3250 m<sup>2</sup>

Pkrusz.=0,3100 m<sup>2</sup>

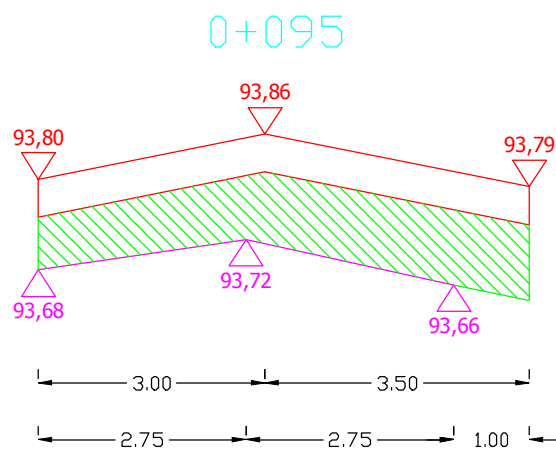

Pwyr.=0,5800 m<sup>2</sup>

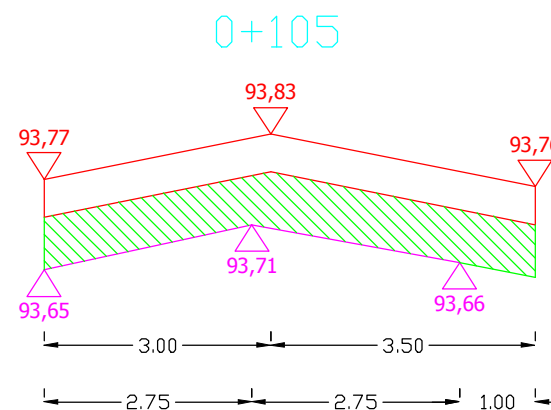

Pwyr.=0,4538 m<sup>2</sup>

Sporządził:

# PRZEKROJE POPRZECZNE DROGI WOJEWÓDZKIEJ NR 655 OD KM 100+740 DO KM 101+835

SKALA 1:10/100

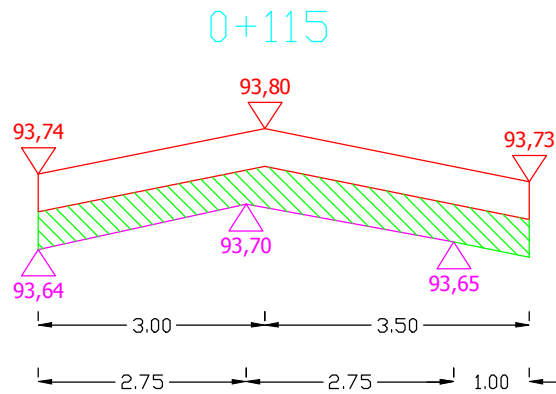

Pwyr.=0,3238 m<sup>2</sup>

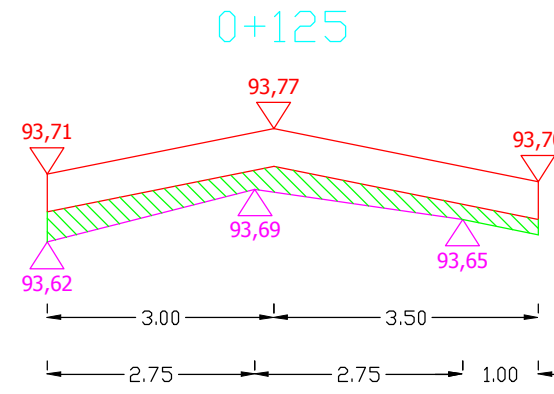

Pwyr.=0,1838 m<sup>2</sup>

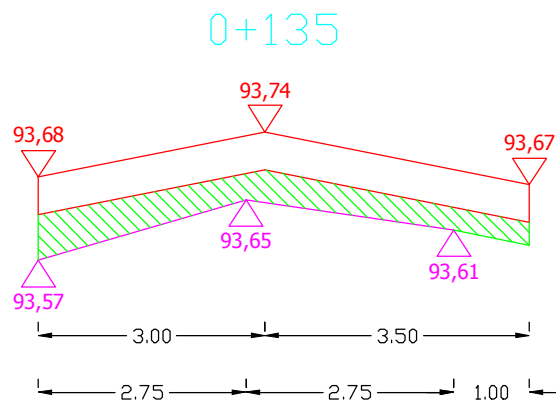

Pwyr.=0,2625 m<sup>2</sup>

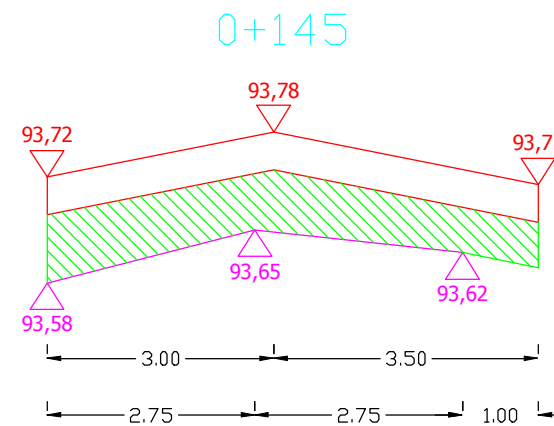

Pwyr.=0,4850 m<sup>2</sup>

Sporządził:

# PRZEKROJE POPRZECZNE DROGI WOJEWÓDZKIEJ NR 655 OD KM 100+740 DO KM 101+835

SKALA 1:10/100

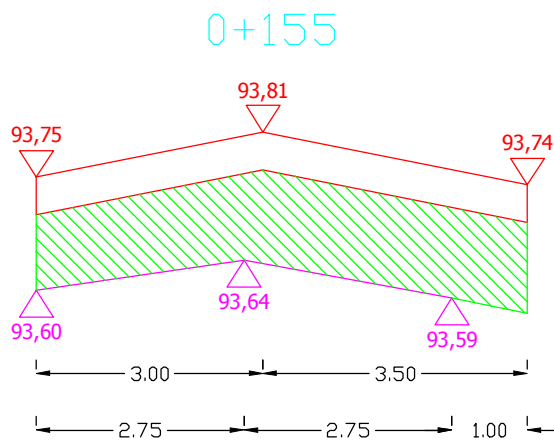

Pwyr.=0,7513 m<sup>2</sup>

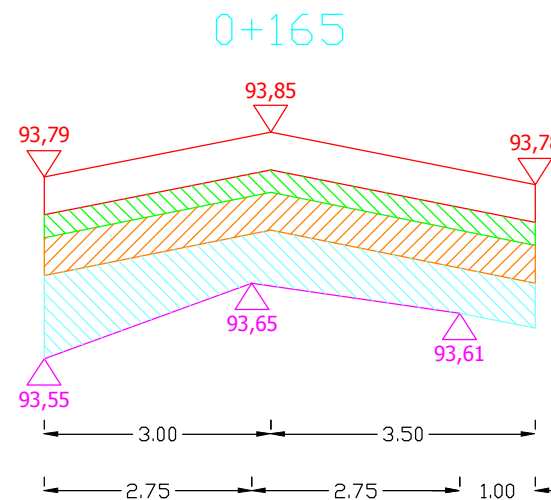

Pwyr.=0,1950 m<sup>2</sup>

Pwiąż.=0,3250 m<sup>2</sup>

Pkrusz.=0,4850 m<sup>2</sup>

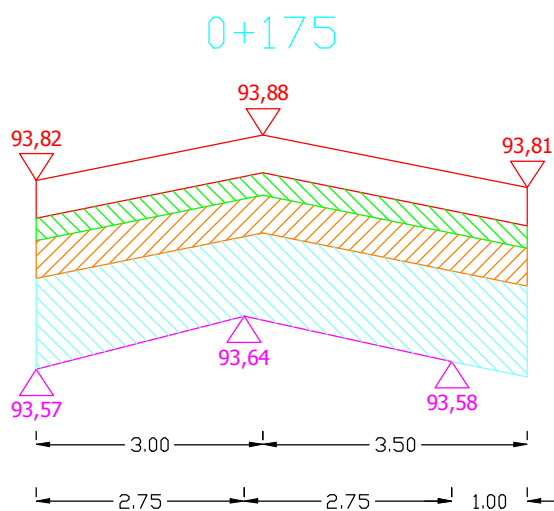

Pwyr.=0,1950 m<sup>2</sup>

Pwiąż.=0,3250 m<sup>2</sup>

Pkrusz.=0,7513 m<sup>2</sup>

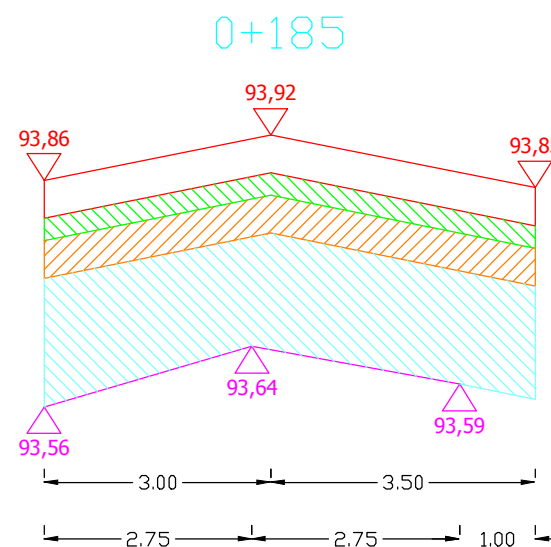

Pwyr.=0,1950 m<sup>2</sup>

Pwiąż.=0,3250 m<sup>2</sup>

Pkrusz.=1,0013 m<sup>2</sup>

Sporządził:

# PRZEKROJE POPRZECZNE DROGI WOJEWÓDZKIEJ NR 655 OD KM 100+740 DO KM 101+835

SKALA 1:10/100

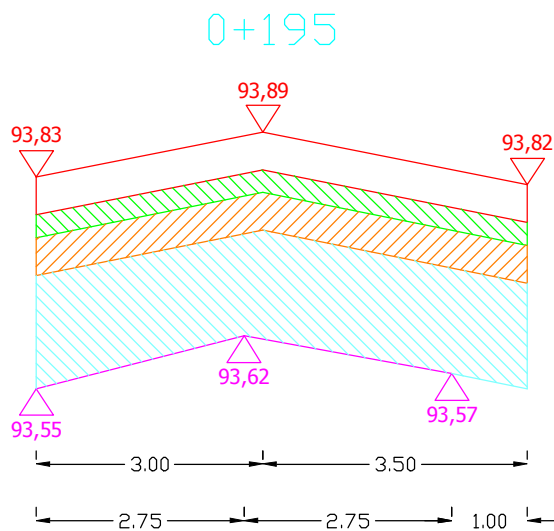

Pwyr.=0,1950 m<sup>2</sup>

Pwiąż.=0,3250 m<sup>2</sup>

Pkrusz.=0,9225 m<sup>2</sup>

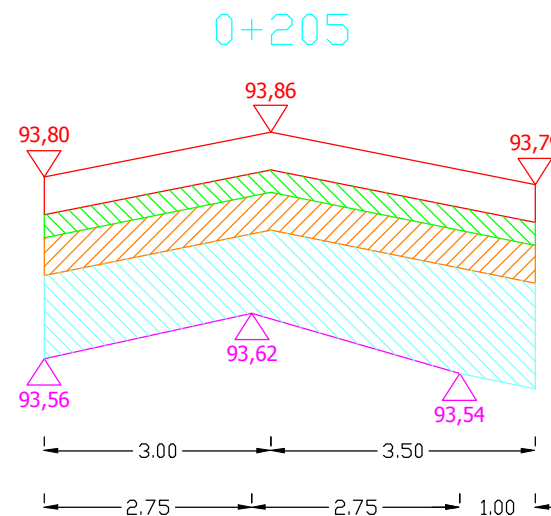

Pwyr.=0,1950 m<sup>2</sup>

Pwiąż.=0,3250 m<sup>2</sup>

Pkrusz.=0,7850 m<sup>2</sup>

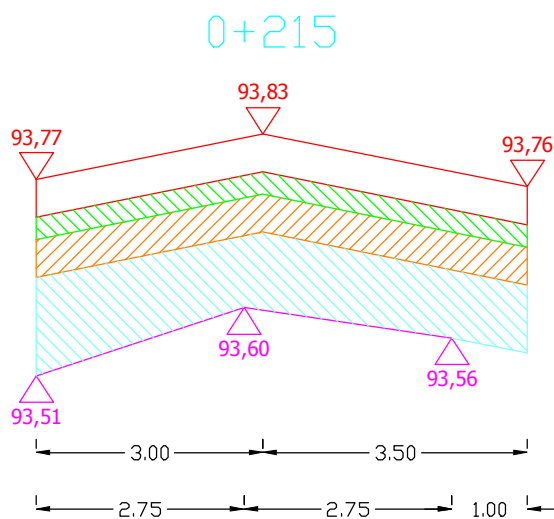

Pwyr.=0,1950 m<sup>2</sup>

Pwiąż.=0,3250 m<sup>2</sup>

Pkrusz.=0,6663 m<sup>2</sup>

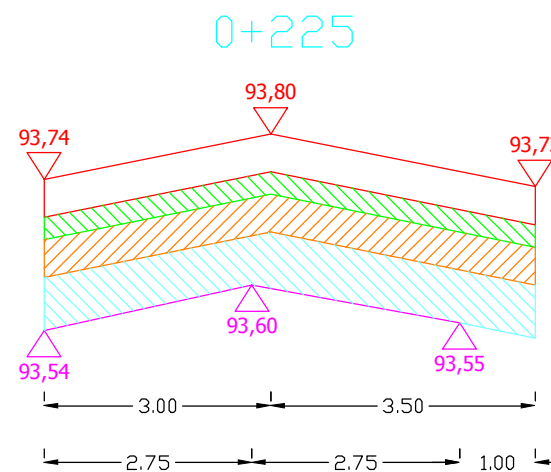

Pwyr.=0,1950 m<sup>2</sup>

Pwiąż.=0,3250 m<sup>2</sup>

Pkrusz.=0,4538 m<sup>2</sup>

Sporządził:

# PRZEKROJE POPRZECZNE DROGI WOJEWÓDZKIEJ NR 655 OD KM 100+740 DO KM 101+835

SKALA 1:10/100

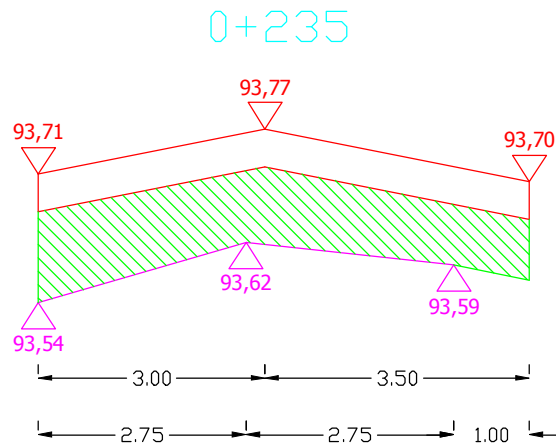

Pwyr.=0,6288 m<sup>2</sup>

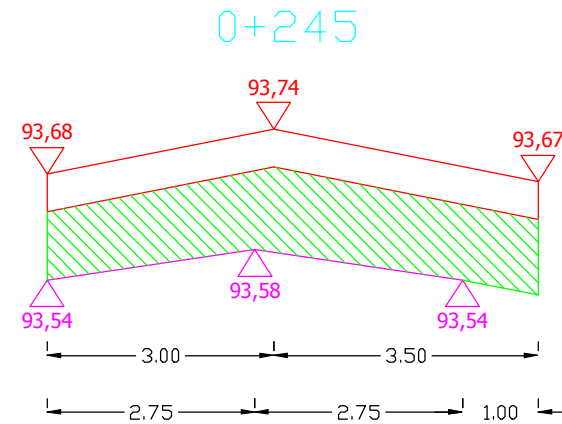

Pwyr.=0,6625 m<sup>2</sup>

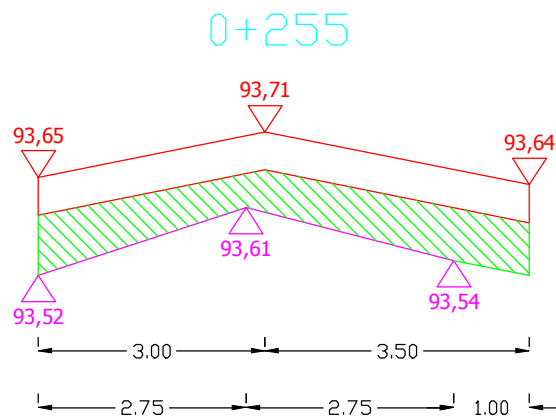

Pwyr.=0,4125 m<sup>2</sup>

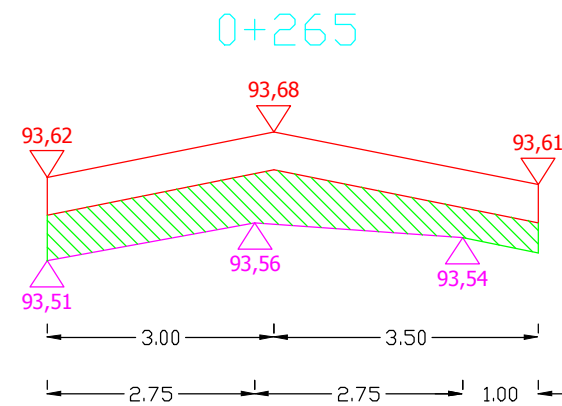

Pwyr.=0,3688 m<sup>2</sup>

Sporządził:

# PRZEKROJE POPRZECZNE DROGI WOJEWÓDZKIEJ NR 655 OD KM 100+740 DO KM 101+835

SKALA 1:10/100

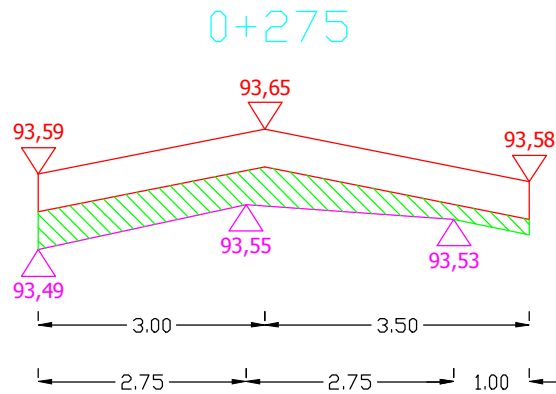

Pwyr.=0,2525 m<sup>2</sup>

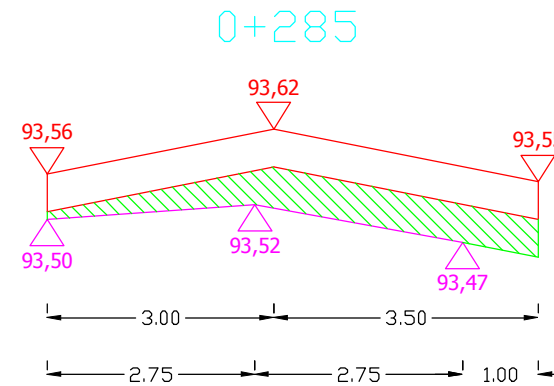

Pwyr.=0,2688 m<sup>2</sup>

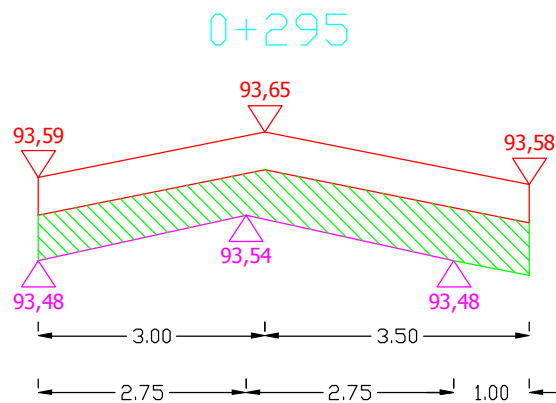

Pwyr.=0,4125 m<sup>2</sup>

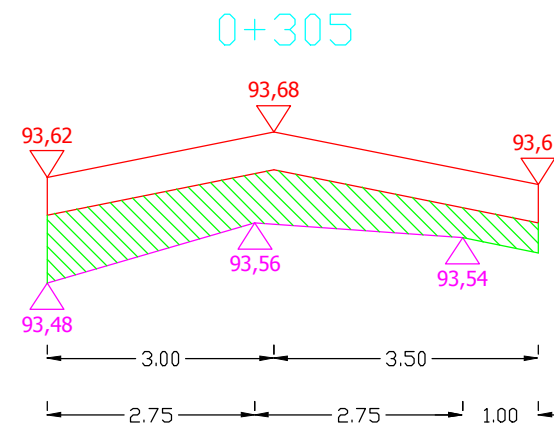

Pwyr.=0,4100 m<sup>2</sup>

Sporządził:



# PRZEKROJE POPRZECZNE DROGI WOJEWÓDZKIEJ NR 655 OD KM 100+740 DO KM 101+835

SKALA 1:10/100

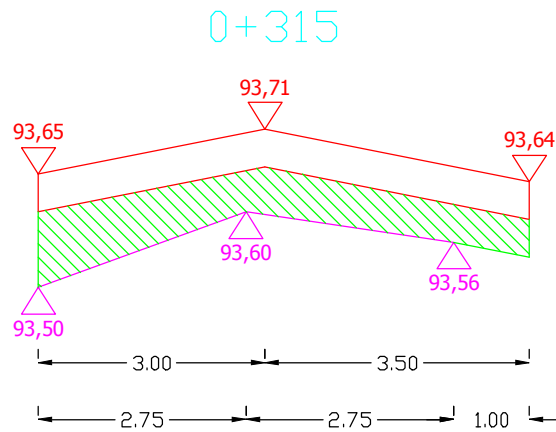

Pwyr.=0,4200 m<sup>2</sup>

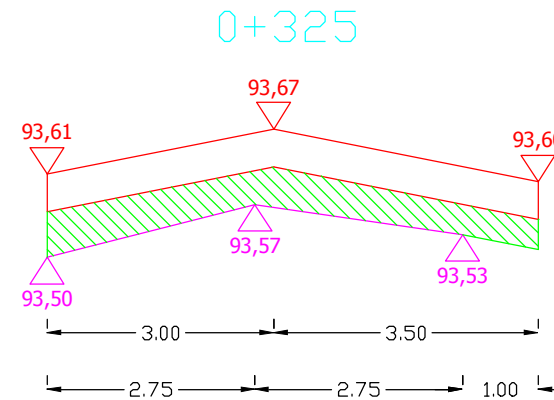

Pwyr.=0,3138 m<sup>2</sup>

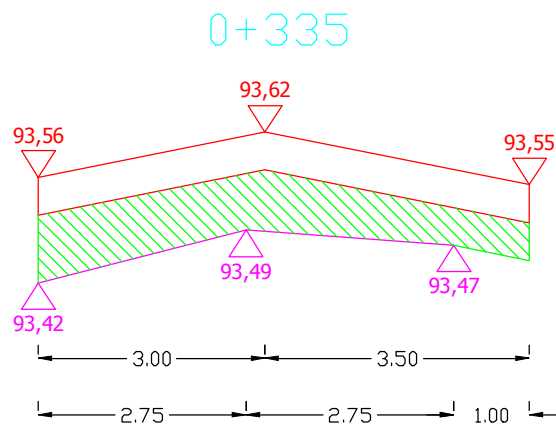

Pwyr.=0,4613 m<sup>2</sup>

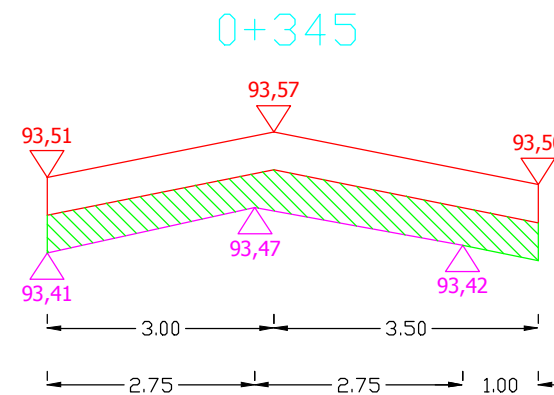

Pwyr.=0,3238 m<sup>2</sup>

Sporządził:

# PRZEKROJE POPRZECZNE DROGI WOJEWÓDZKIEJ NR 655 OD KM 100+740 DO KM 101+835

SKALA 1:10/100

0+355

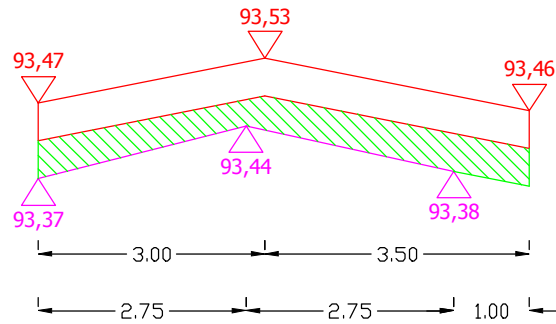

Pwyr.=0,2963 m<sup>2</sup>

0+365

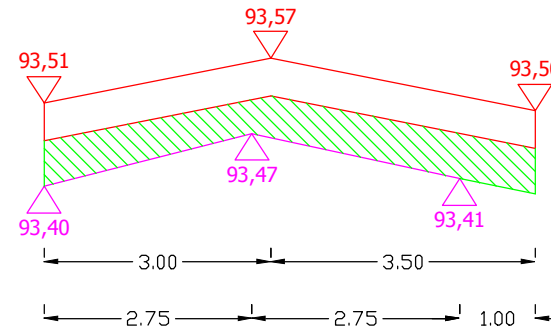

Pwyr.=0,3613 m<sup>2</sup>

0+375

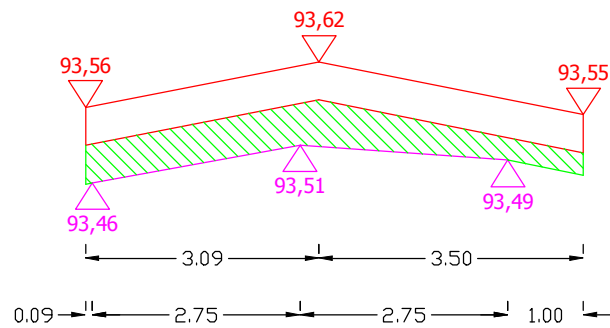

Pwyr.=0,3110 m<sup>2</sup>

0+385

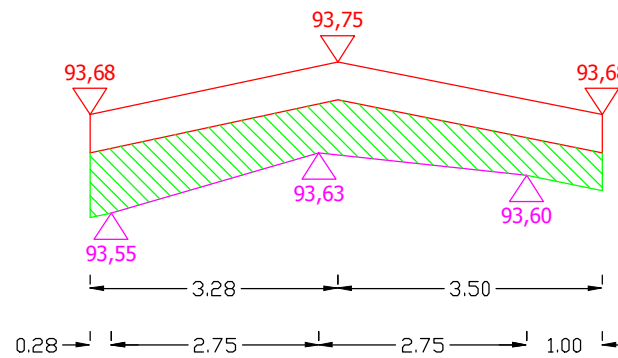

Pwyr.=0,4518 m<sup>2</sup>

Sporządził:

# PRZEKROJE POPRZECZNE DROGI WOJEWÓDZKIEJ NR 655 OD KM 100+740 DO KM 101+835

SKALA 1:10/100

0+395

Pwyr.=0,3750 m<sup>2</sup>

0+405

Pwyr.=0,4500 m<sup>2</sup>

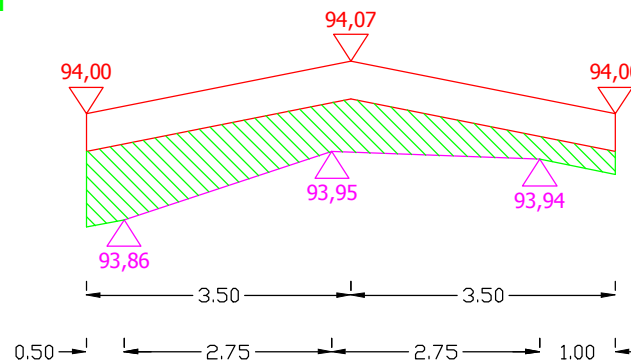
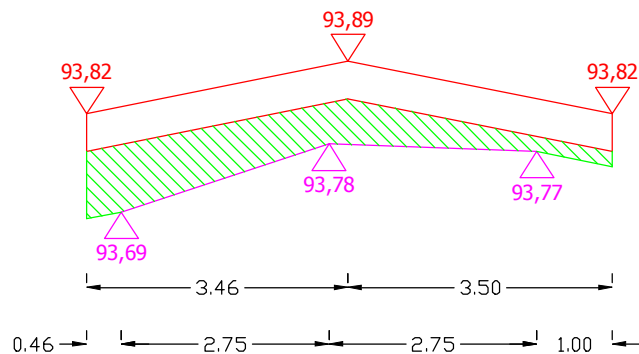

0+415

Pwyr.=0,3438 m<sup>2</sup>

0+425

Pwyr.=0,2600 m<sup>2</sup>

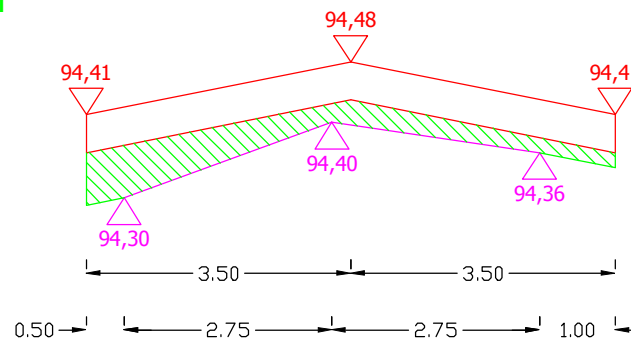
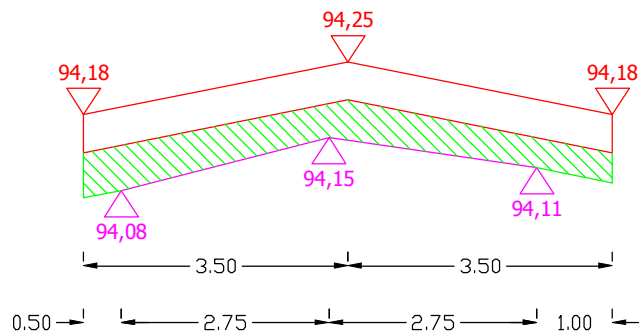

Sporządził:

# PRZEKROJE POPRZECZNE DROGI WOJEWÓDZKIEJ NR 655 OD KM 100+740 DO KM 101+835

SKALA 1:10/100

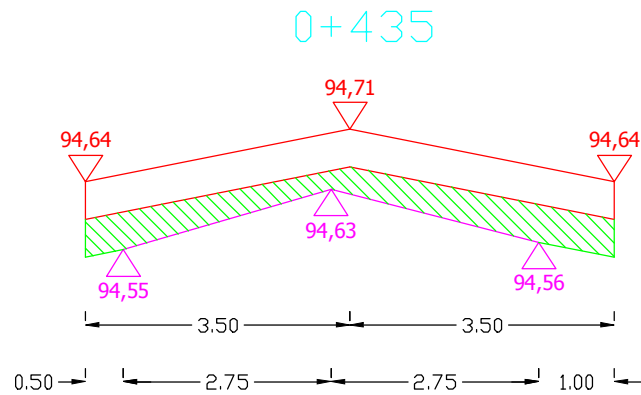

Pwyr.=0,2938 m<sup>2</sup>

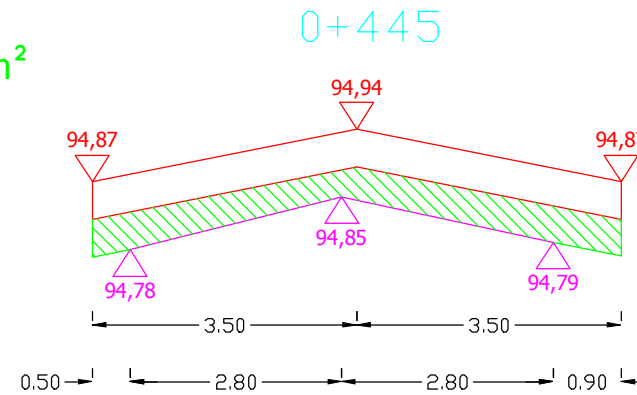

Pwyr.=0,3166 m<sup>2</sup>

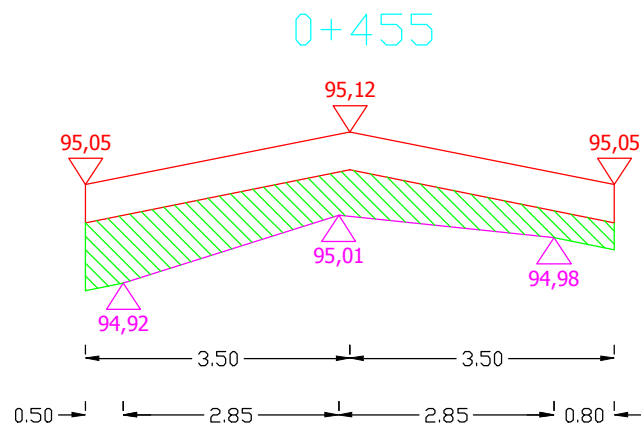

Pwyr.=0,4241 m<sup>2</sup>

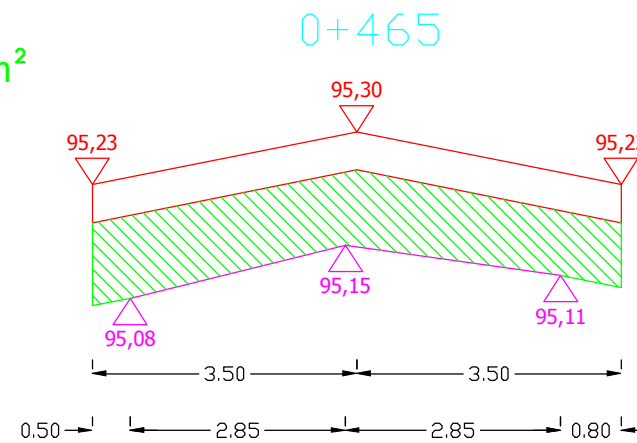

Pwyr.=0,6877 m<sup>2</sup>

Sporządził:

# PRZEKROJE POPRZECZNE DROGI WOJEWÓDZKIEJ NR 655 OD KM 100+740 DO KM 101+835

SKALA 1:10/100

0+475

Pwyr.=0,5400 m<sup>2</sup>

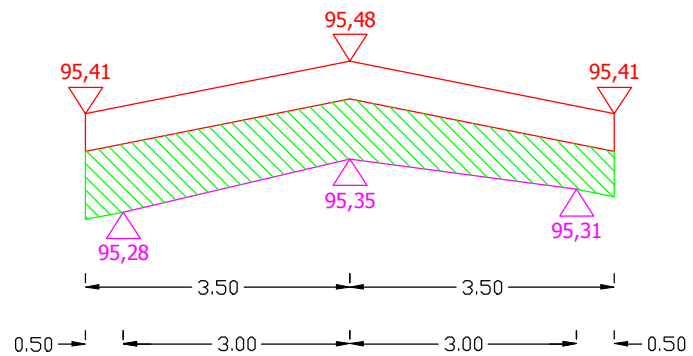

0+485

Pwyr.=0,4300 m<sup>2</sup>

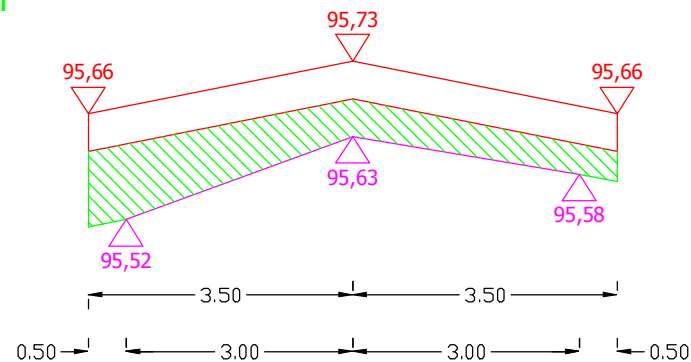

0+495

Pwyr.=0,3800 m<sup>2</sup>

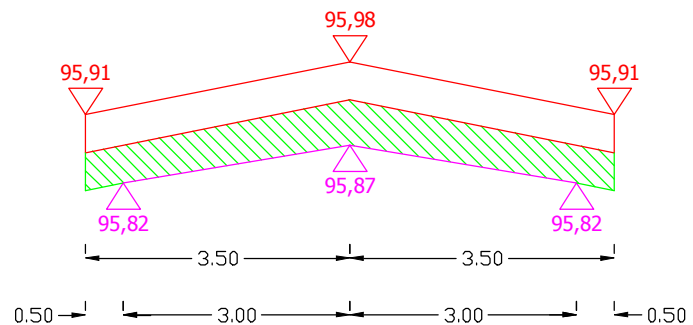

0+505

Pwyr.=0,2447 m<sup>2</sup>

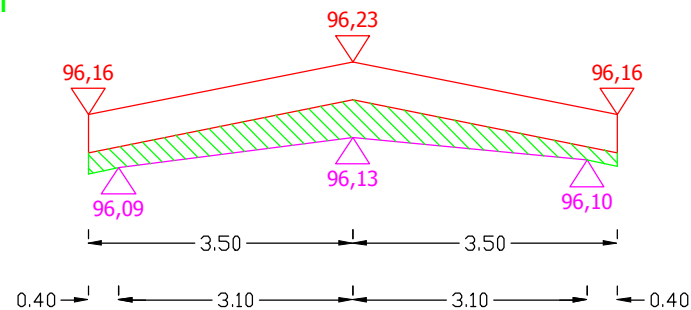

Sporządził:

# PRZEKROJE POPRZECZNE DROGI WOJEWÓDZKIEJ NR 655 OD KM 100+740 DO KM 101+835

SKALA 1:10/100

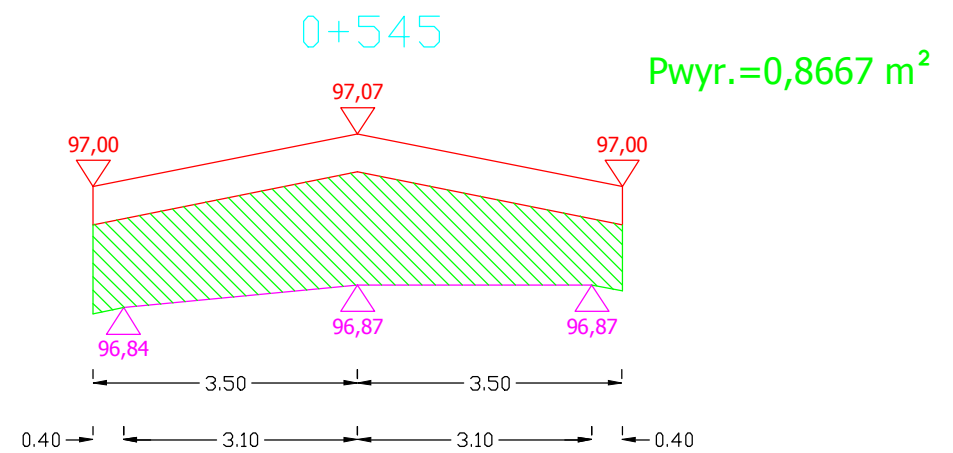
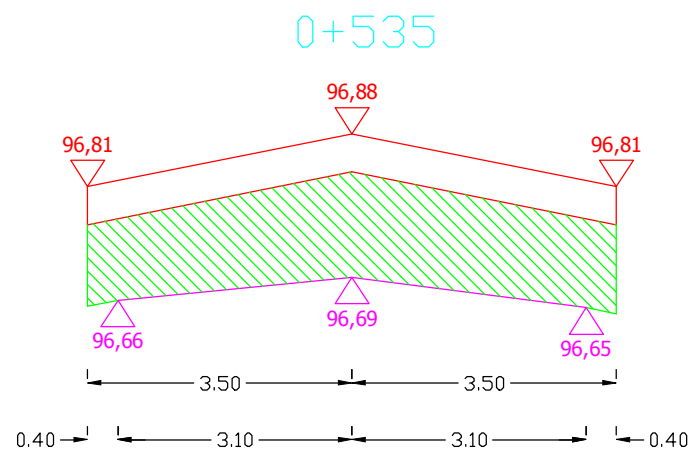
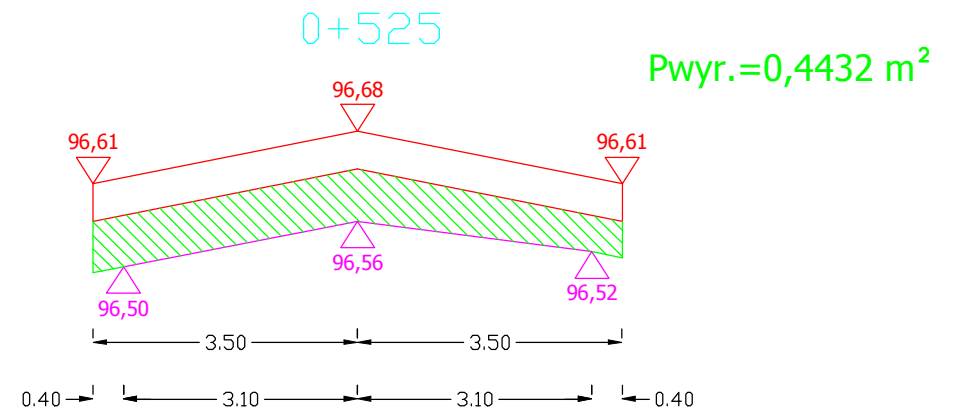
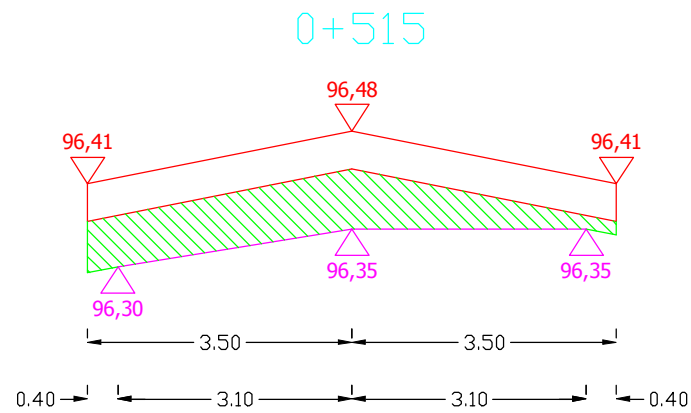

Sporządził:

# PRZEKROJE POPRZECZNE DROGI WOJEWÓDZKIEJ NR 655 OD KM 100+740 DO KM 101+835

SKALA 1:10/100

0+555

Pwyr.=0,6337 m<sup>2</sup>

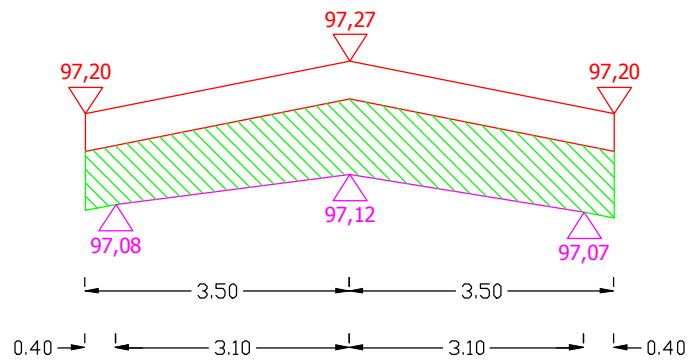

0+565

Pwyr.=0,6027 m<sup>2</sup>

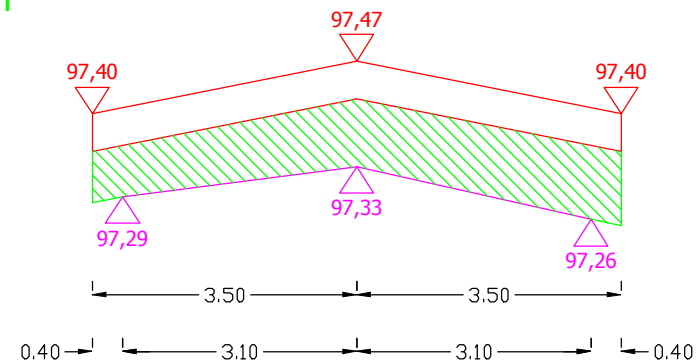

0+575

Pwyr.=0,4627 m<sup>2</sup>

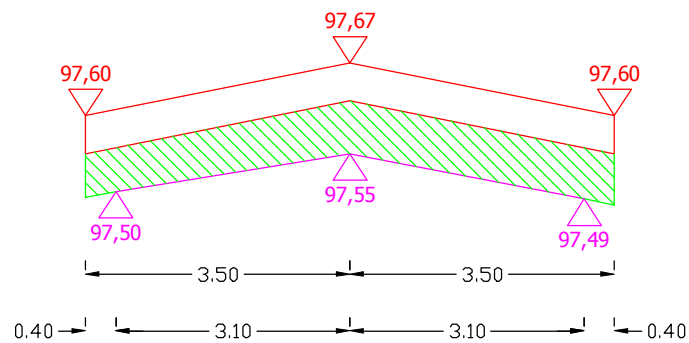

0+585

Pwyr.=0,3537 m<sup>2</sup>

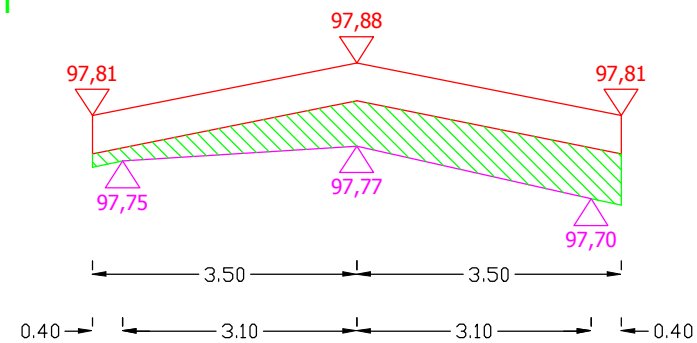

Sporządził:

# PRZEKROJE POPRZECZNE DROGI WOJEWÓDZKIEJ NR 655 OD KM 100+740 DO KM 101+835

SKALA 1:10/100

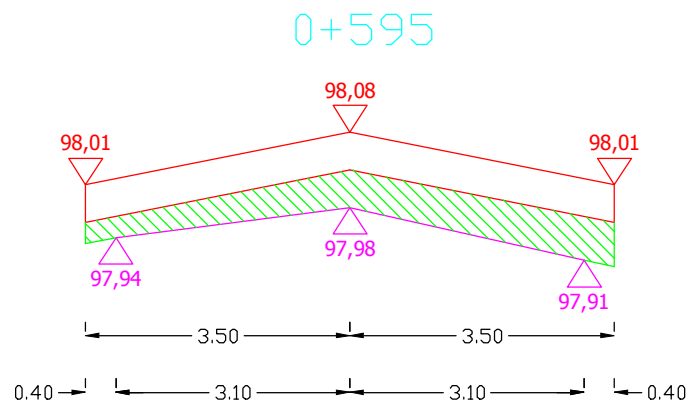

Pwyr.=0,3227 m<sup>2</sup>

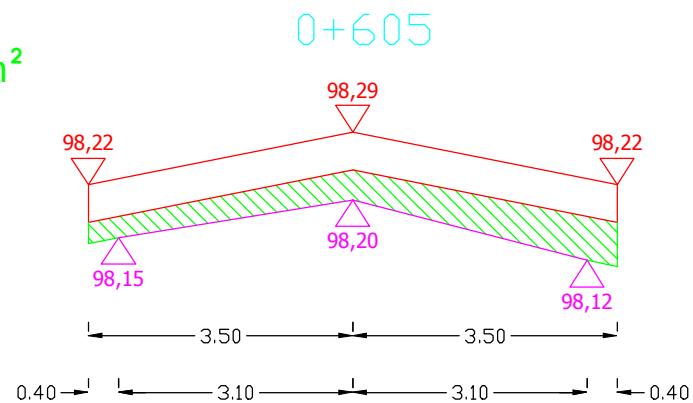

Pwyr.=0,2917 m<sup>2</sup>

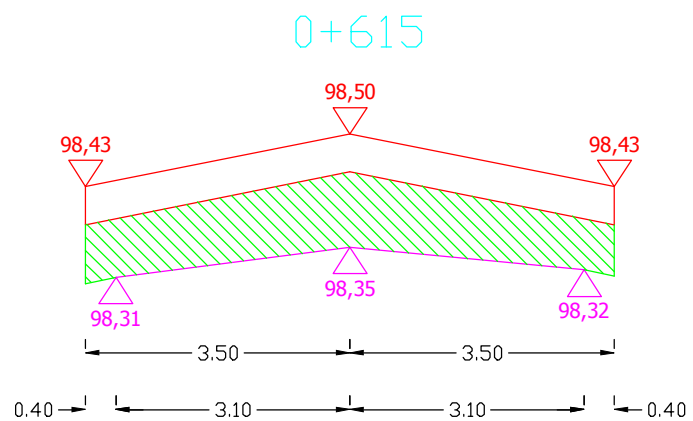

Pwyr.=0,5947 m<sup>2</sup>

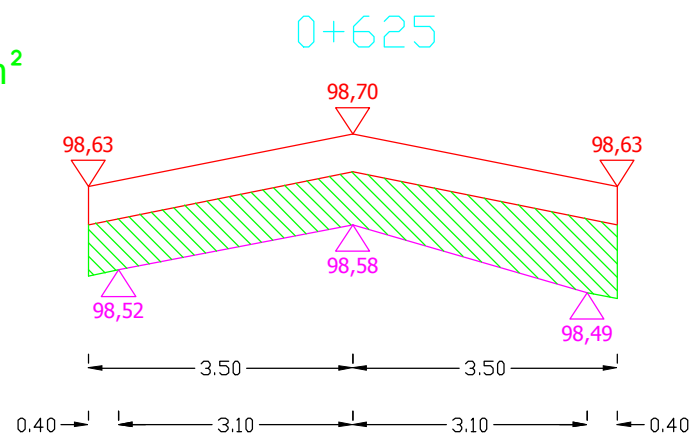

Pwyr.=0,5407 m<sup>2</sup>

Sporządził:



# PRZEKROJE POPRZECZNE DROGI WOJEWÓDZKIEJ NR 655 OD KM 100+740 DO KM 101+835

SKALA 1:10/100

0+635

Pwyr.=0,5327 m<sup>2</sup>

0+645

Pwyr.=0,3927 m<sup>2</sup>

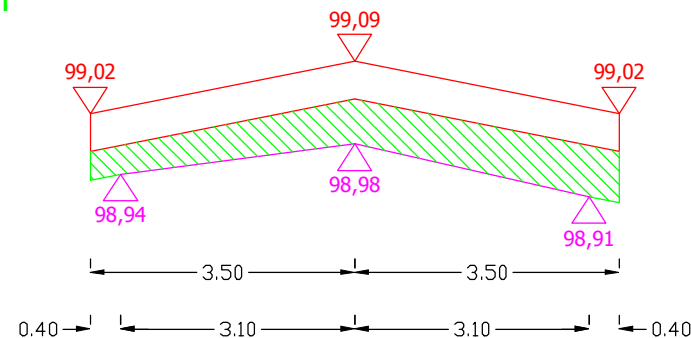
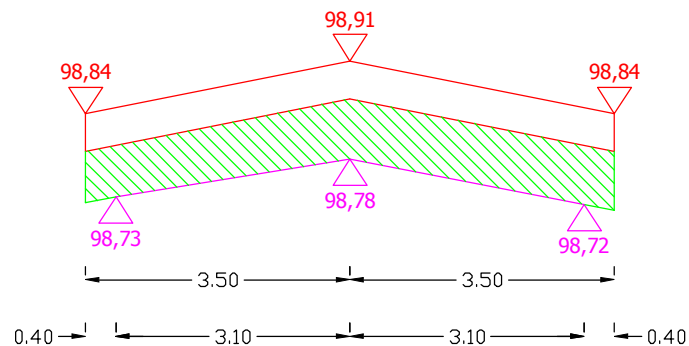

0+655

Pwyr.=0,2100 m<sup>2</sup>

0+665

Pwyr.=0,2100 m<sup>2</sup>

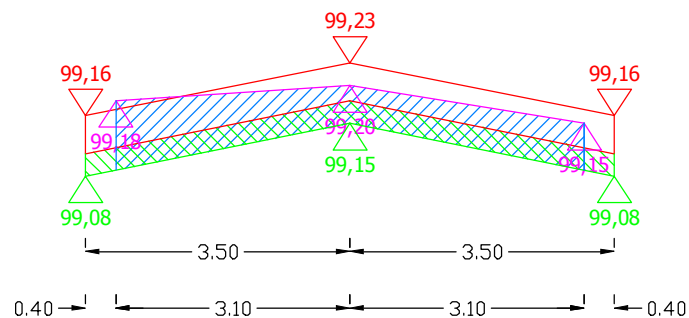

Pfrez.=0,3937 m<sup>2</sup>

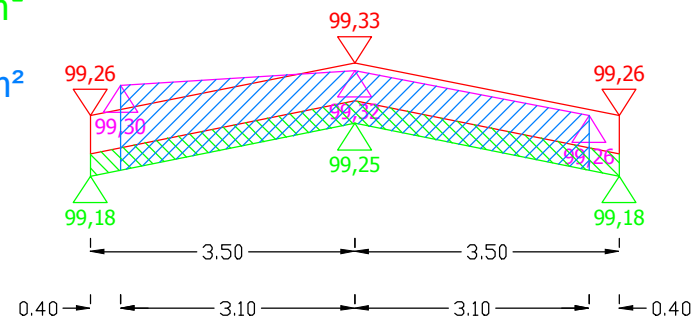

Pfrez.=0,5022 m<sup>2</sup>

Sporządził:

# PRZEKROJE POPRZECZNE DROGI WOJEWÓDZKIEJ NR 655 OD KM 100+740 DO KM 101+835

SKALA 1:10/100

0+675

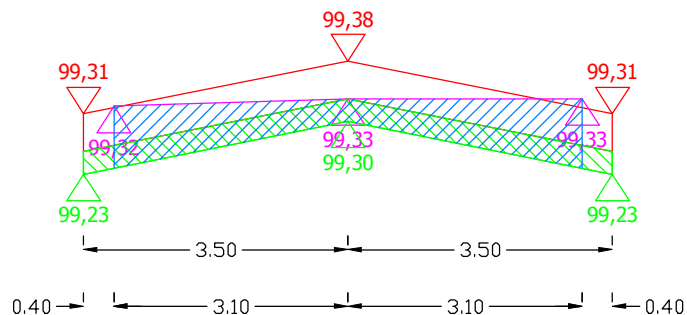

Pwyr.=0,2100 m<sup>2</sup>

Pfrez.=0,3627 m<sup>2</sup>

0+685

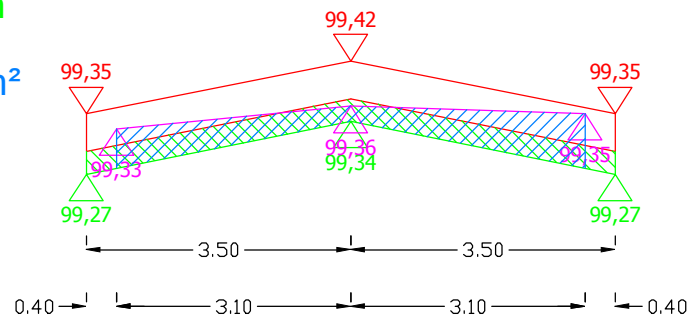

Pwyr.=0,2100 m<sup>2</sup>

Pfrez.=0,2542 m<sup>2</sup>

0+695

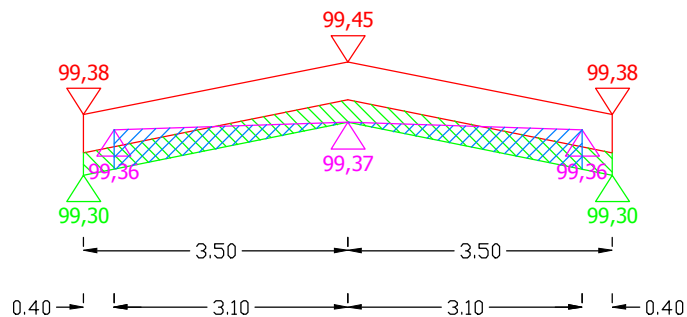

Pwyr.=0,2100 m<sup>2</sup>

Pfrez.=0,1612 m<sup>2</sup>

0+705

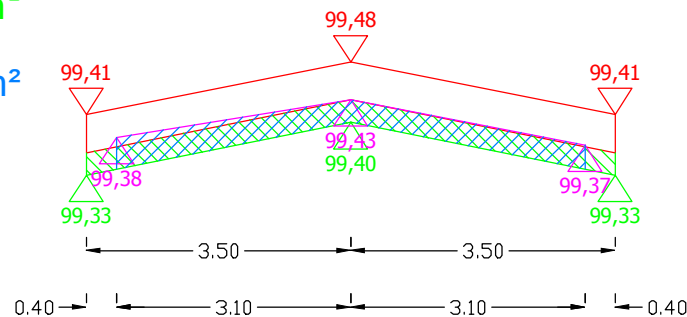

Pwyr.=0,2100 m<sup>2</sup>

Pfrez.=0,2077 m<sup>2</sup>

Sporządził:

# PRZEKROJE POPRZECZNE DROGI WOJEWÓDZKIEJ NR 655 OD KM 100+740 DO KM 101+835

SKALA 1:10/100

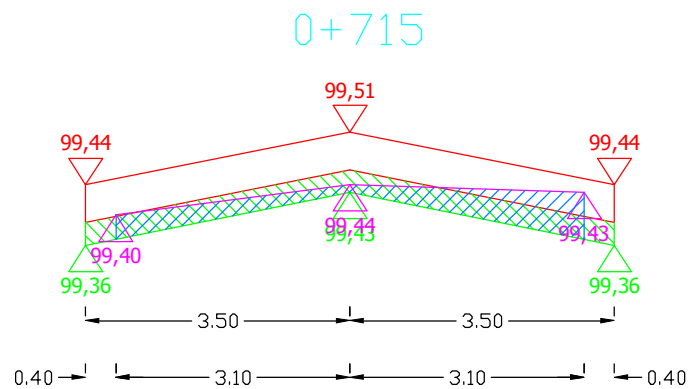

Pwyr.=0,2100 m<sup>2</sup>

Pfrez.=0,1767 m<sup>2</sup>

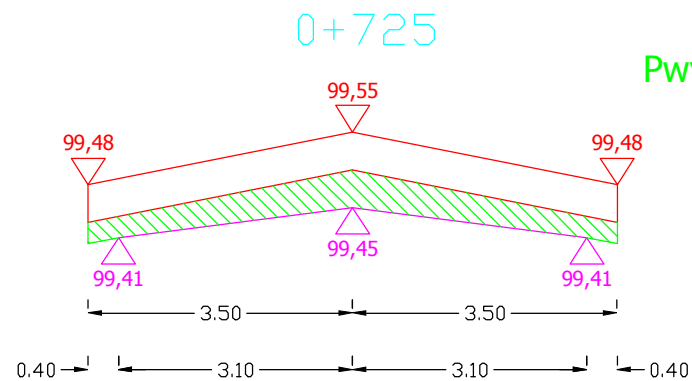

Pwyr.=0,2642 m<sup>2</sup>

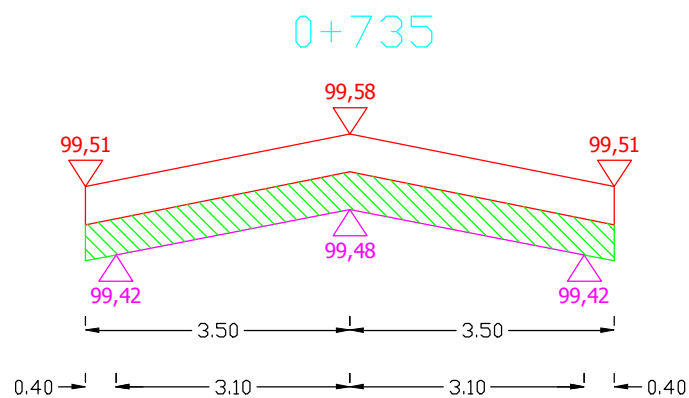

Pwyr.=0,3422 m<sup>2</sup>

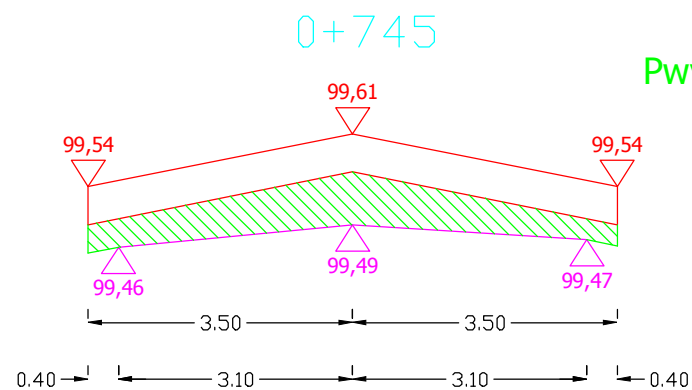

Pwyr.=0,3457 m<sup>2</sup>

Sporządził:

# PRZEKROJE POPRZECZNE DROGI WOJEWÓDZKIEJ NR 655 OD KM 100+740 DO KM 101+835

SKALA 1:10/100

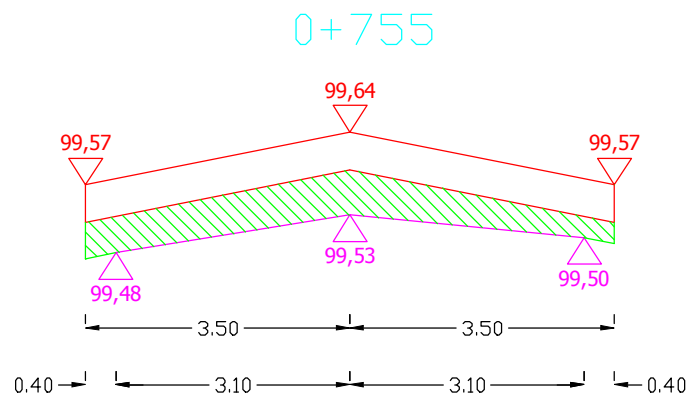

Pwyr.=0,3342 m<sup>2</sup>

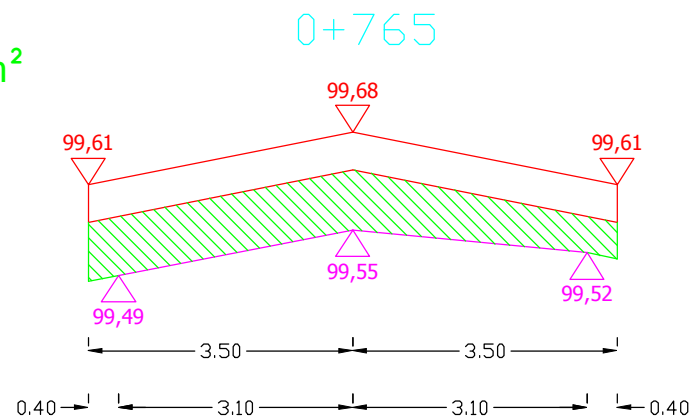

Pwyr.=0,4937 m<sup>2</sup>

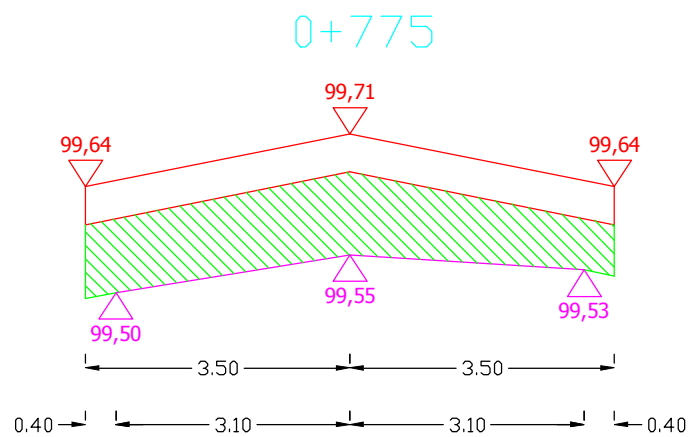

Pwyr.=0,6647 m<sup>2</sup>

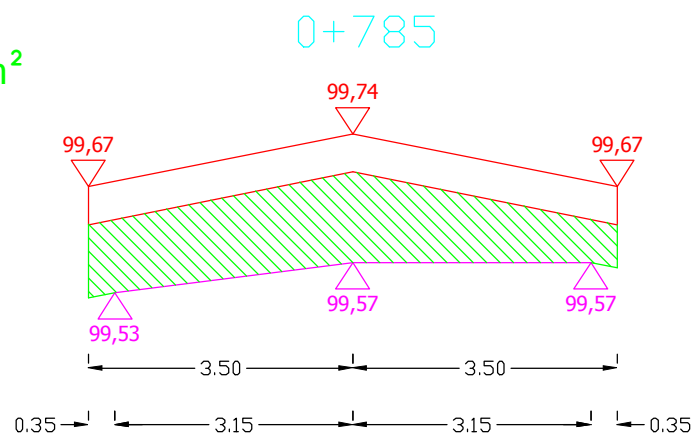

Pwyr.=0,6745 m<sup>2</sup>

Sporządził:

# PRZEKROJE POPRZECZNE DROGI WOJEWÓDZKIEJ NR 655 OD KM 100+740 DO KM 101+835

SKALA 1:10/100

0+795

Pwyr.=0,6598 m<sup>2</sup>

0+805

Pwyr.=0,6848 m<sup>2</sup>

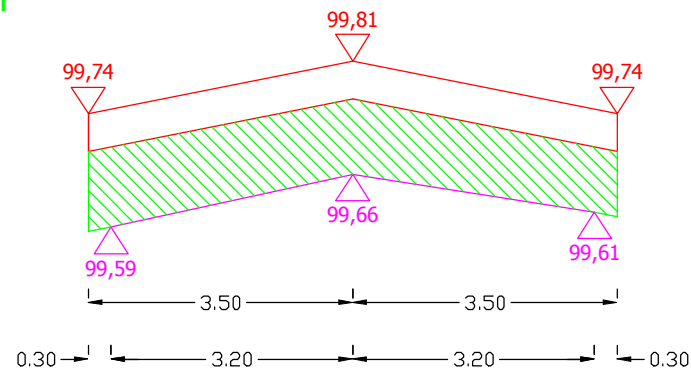
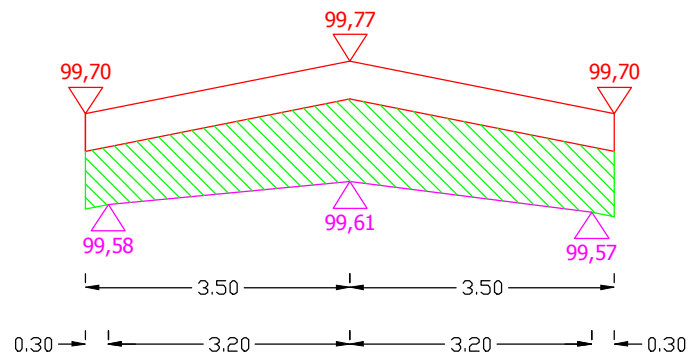

0+815

Pwyr.=0,7678 m<sup>2</sup>

0+825

Pwyr.=0,7998 m<sup>2</sup>

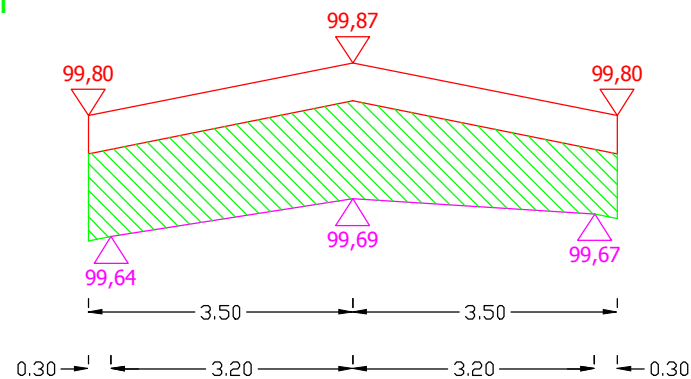
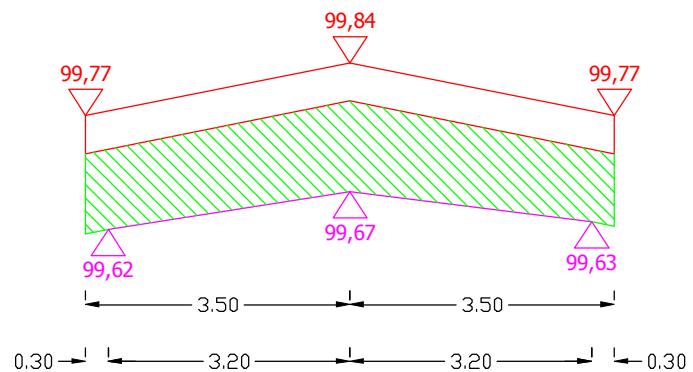

Sporządził:

# PRZEKROJE POPRZECZNE DROGI WOJEWÓDZKIEJ NR 655 OD KM 100+740 DO KM 101+835

SKALA 1:10/100

0+835

Pwyr.=0,6468 m<sup>2</sup>

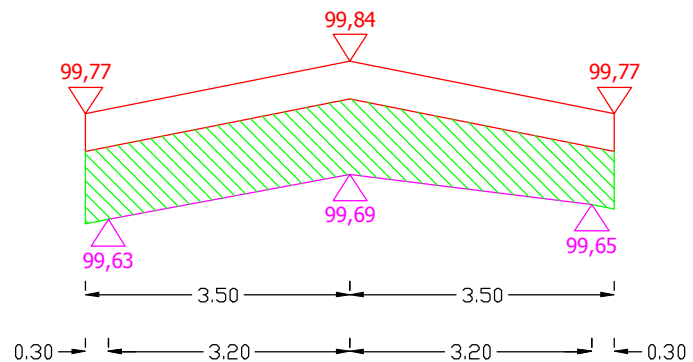

0+845

Pwyr.=0,3098 m<sup>2</sup>

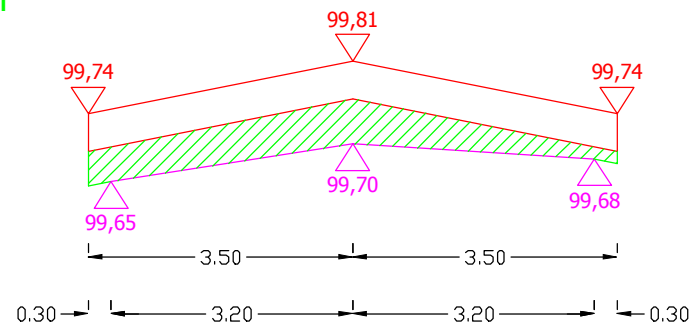

0+855

Pwyr.=0,2908 m<sup>2</sup>

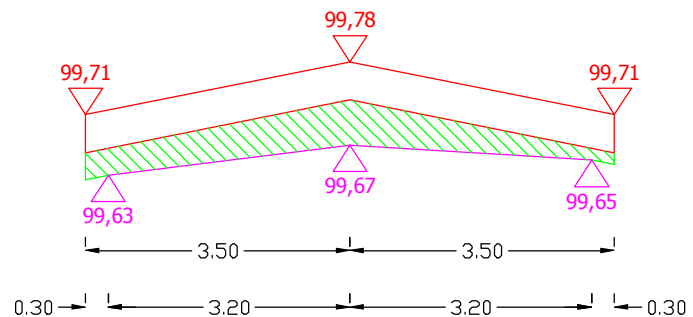

0+865

Pwyr.=0,2398 m<sup>2</sup>

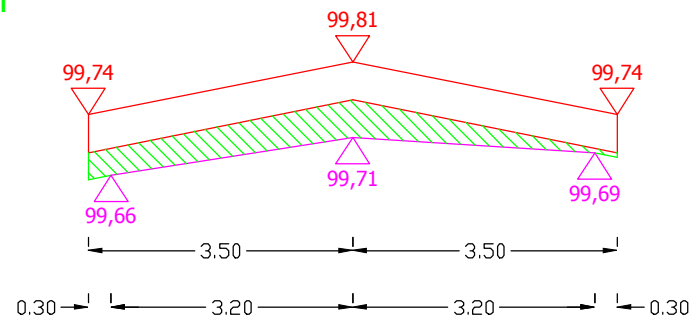

Sporządził:

# PRZEKROJE POPRZECZNE DROGI WOJEWÓDZKIEJ NR 655 OD KM 100+740 DO KM 101+835

SKALA 1:10/100

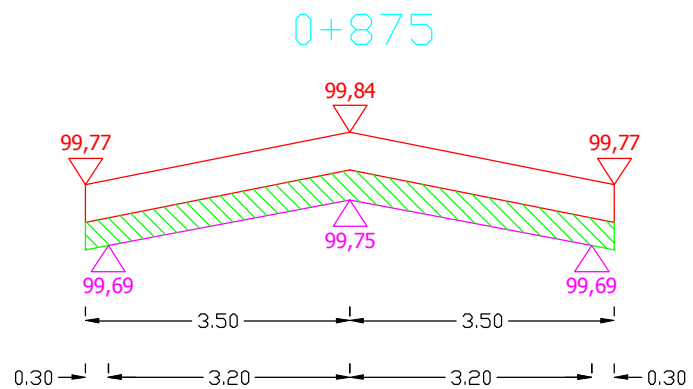

Pwyr.=0,2648 m<sup>2</sup>

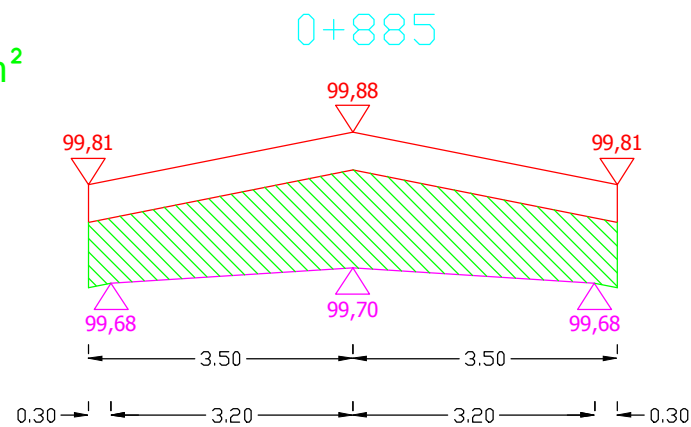

Pwyr.=0,7428 m<sup>2</sup>

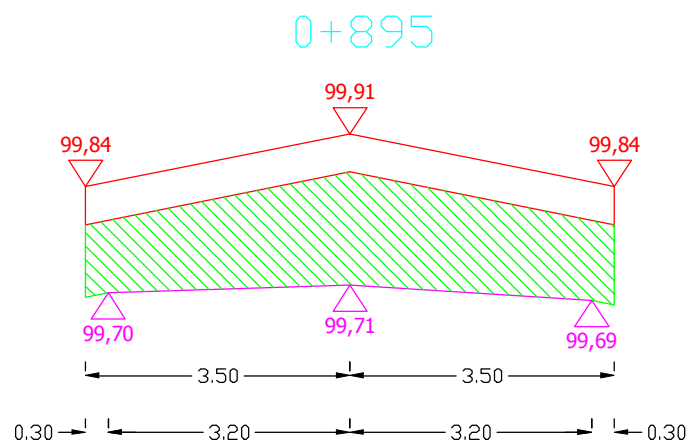

Pwyr.=0,8638 m<sup>2</sup>

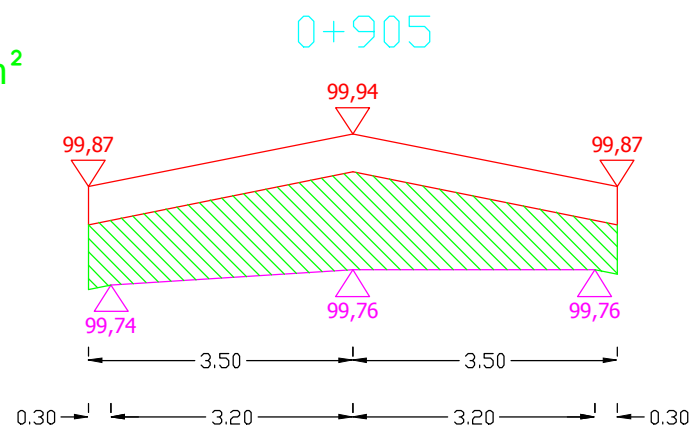

Pwyr.=0,7048 m<sup>2</sup>

Sporządził:

# PRZEKROJE POPRZECZNE DROGI WOJEWÓDZKIEJ NR 655 OD KM 100+740 DO KM 101+835

SKALA 1:10/100

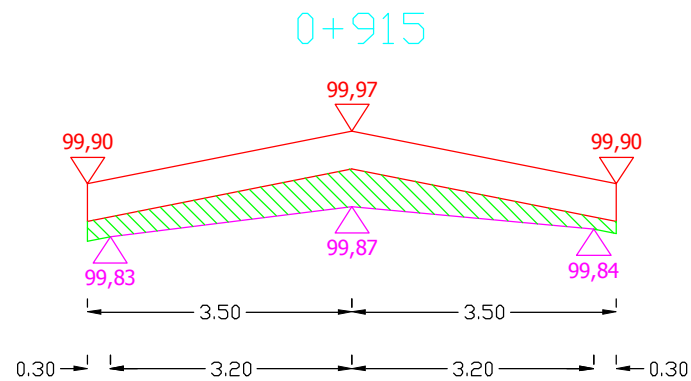

Pwyr.=0,2398 m<sup>2</sup>

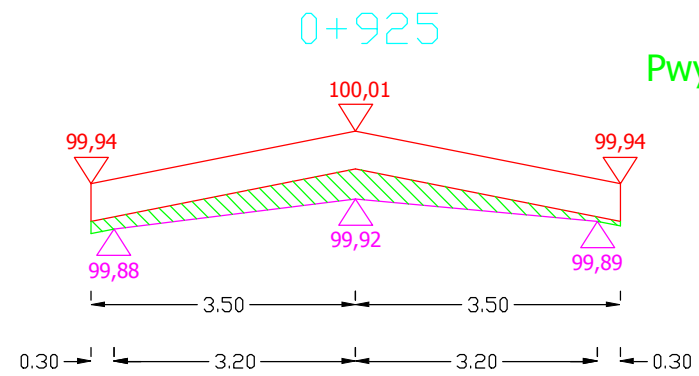

Pwyr.=0,1698 m<sup>2</sup>

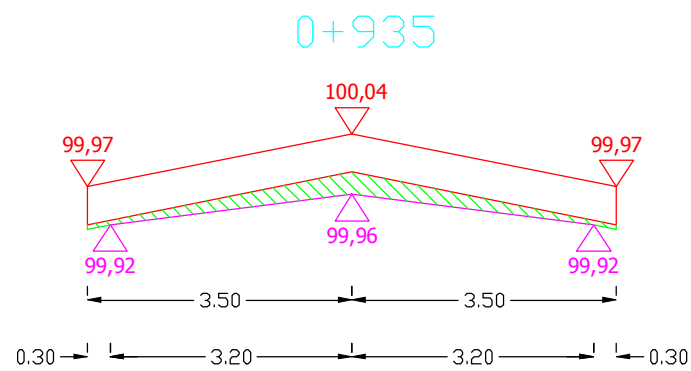

Pwyr.=0,1188 m<sup>2</sup>

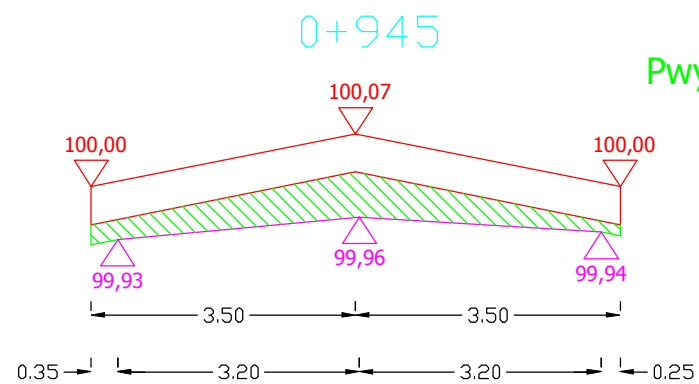

Pwyr.=0,2724 m<sup>2</sup>

Sporządził:



# PRZEKROJE POPRZECZNE DROGI WOJEWÓDZKIEJ NR 655 OD KM 100+740 DO KM 101+835

SKALA 1:10/100

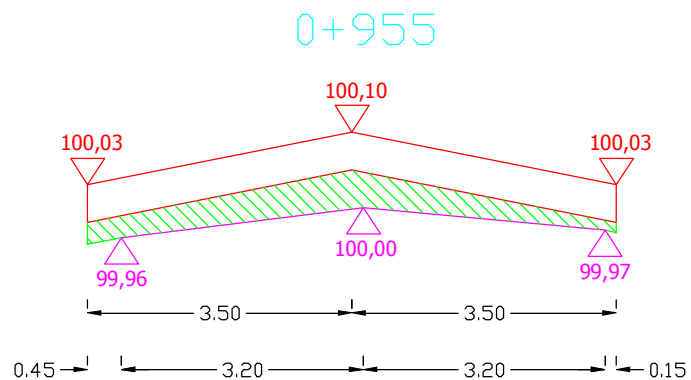

Pwyr.=0,2418 m<sup>2</sup>

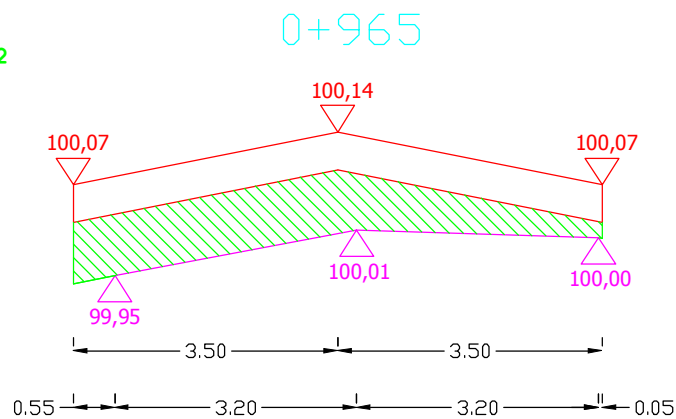

Pwyr.=0,4636 m<sup>2</sup>

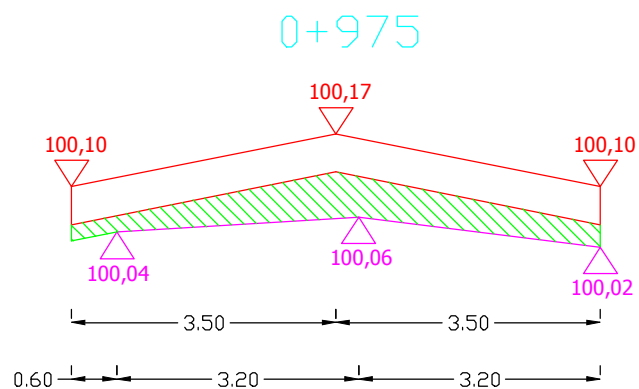

Pwyr.=0,2866 m<sup>2</sup>

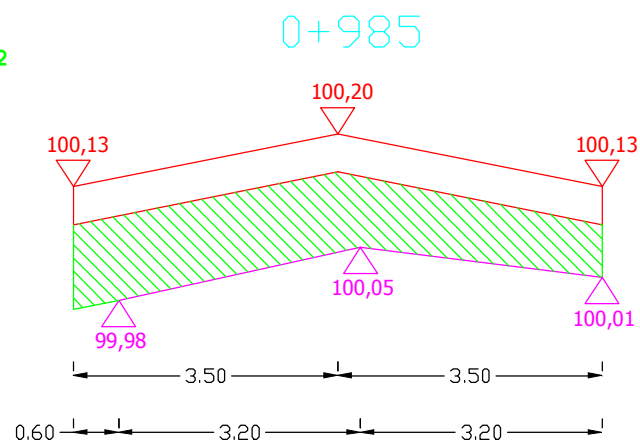

Pwyr.=0,6766 m<sup>2</sup>

Sporządził:

# PRZEKROJE POPRZECZNE DROGI WOJEWÓDZKIEJ NR 655 OD KM 100+740 DO KM 101+835

SKALA 1:10/100

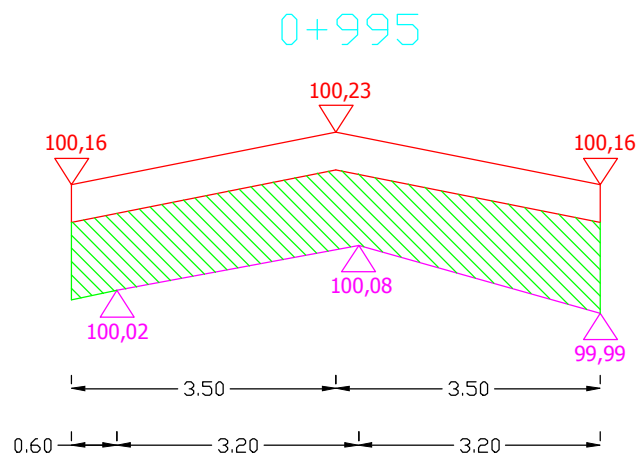

Pwyr.=0,7346 m<sup>2</sup>

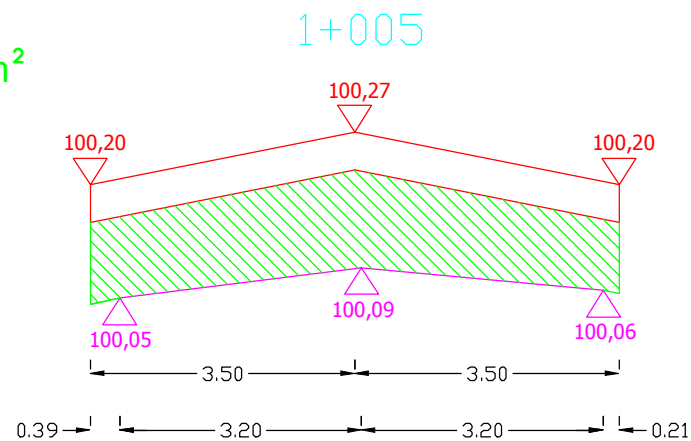

Pwyr.=0,8009 m<sup>2</sup>

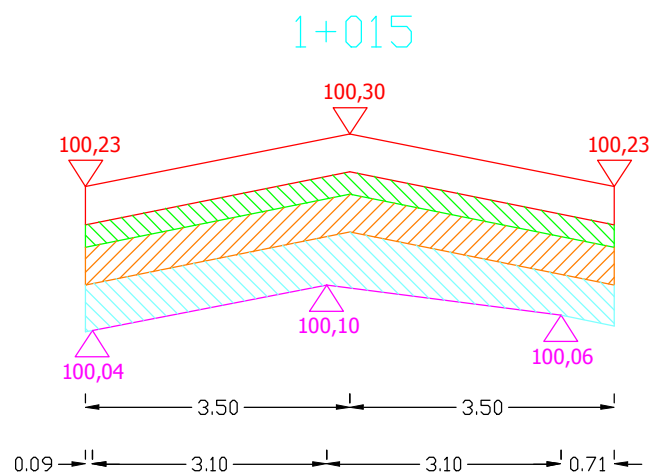

Pwyr.=0,2100 m<sup>2</sup>

Pwiąż.=0,3500 m<sup>2</sup>

Pkrusz.=0,4389 m<sup>2</sup>

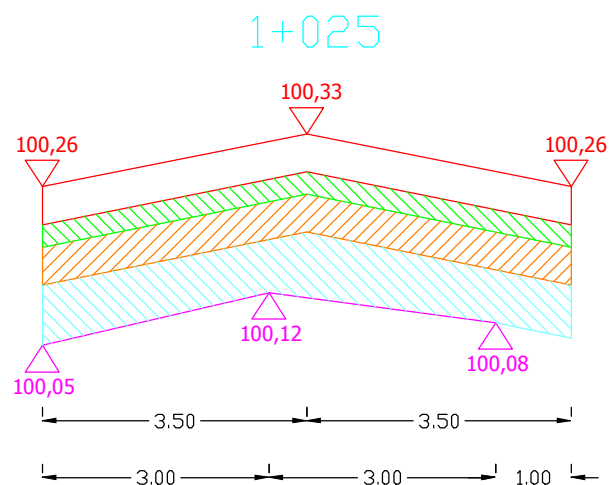

Pwyr.=0,2100 m<sup>2</sup>

Pwiąż.=0,3500 m<sup>2</sup>

Pkrusz.=0,5300 m<sup>2</sup>

Sporządził:

# PRZEKROJE POPRZECZNE DROGI WOJEWÓDZKIEJ NR 655 OD KM 100+740 DO KM 101+835

SKALA 1:10/100

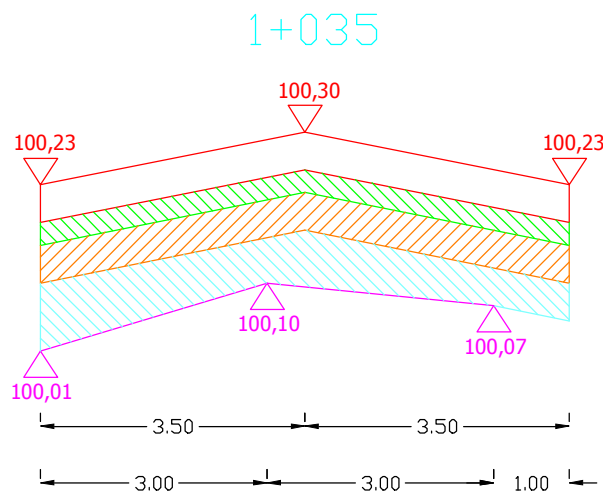

Pwyr.=0,2100 m<sup>2</sup>

Pwiąż.=0,3500 m<sup>2</sup>

Pkrusz.=0,4650 m<sup>2</sup>

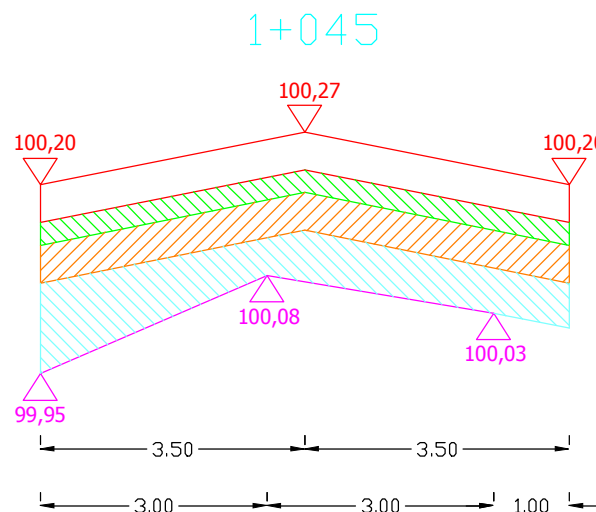

Pwyr.=0,2100 m<sup>2</sup>

Pwiąż.=0,3500 m<sup>2</sup>

Pkrusz.=0,5052 m<sup>2</sup>

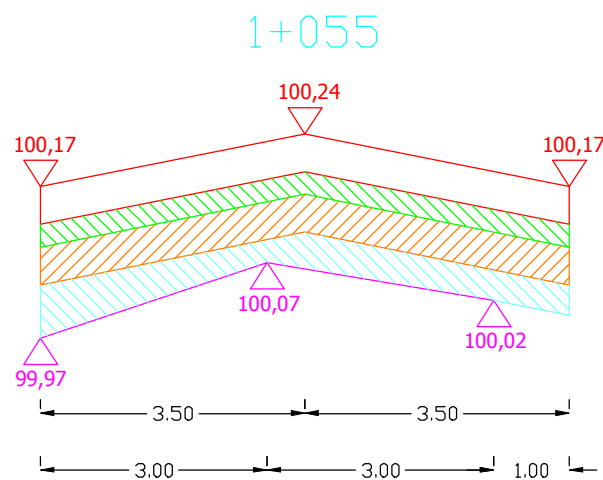

Pwyr.=0,2100 m<sup>2</sup>

Pwiąż.=0,3500 m<sup>2</sup>

Pkrusz.=0,3200 m<sup>2</sup>

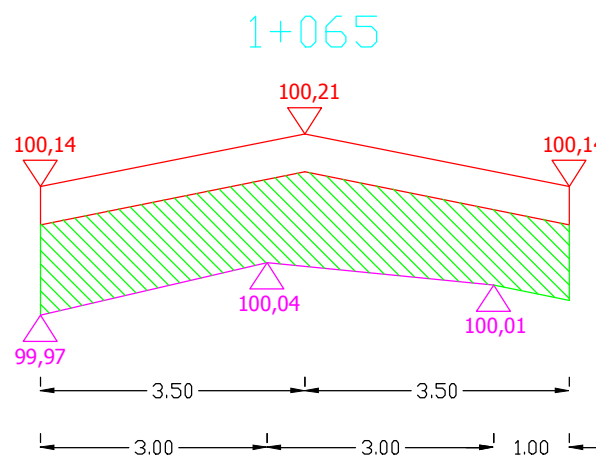

Pwyr.=0,7850 m<sup>2</sup>

Sporządził:

# PRZEKROJE POPRZECZNE DROGI WOJEWÓDZKIEJ NR 655 OD KM 100+740 DO KM 101+835

SKALA 1:10/100

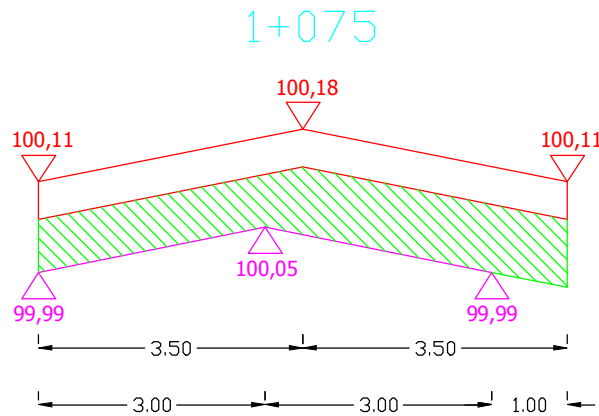

$P_{wyr.} = 0,5650 \text{ m}^2$

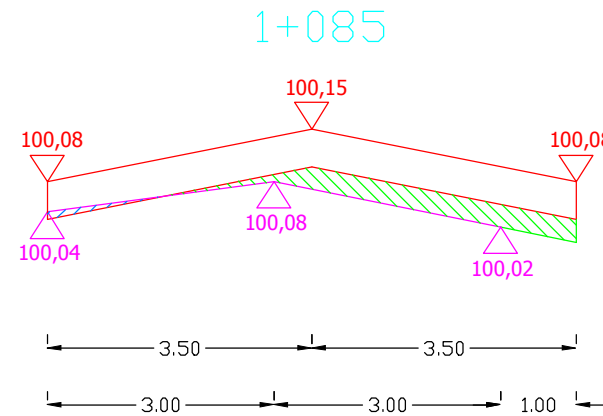

$P_{wyr.} = 0,1220 \text{ m}^2$

$P_{frez.} = 0,0076 \text{ m}^2$

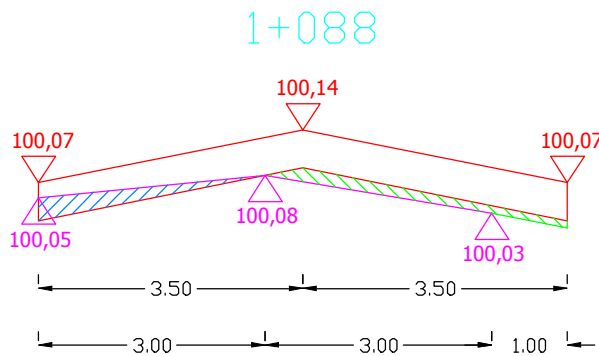

$P_{wyr.} = 0,0500 \text{ m}^2$

$P_{frez.} = 0,0450 \text{ m}^2$

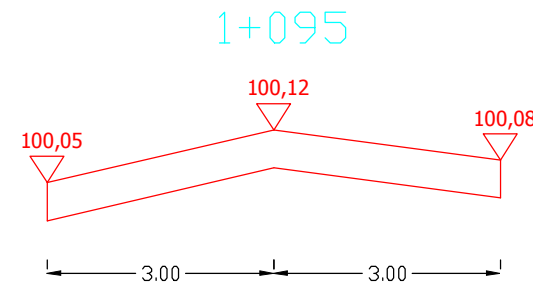

$P_{wyr.} = 0,0000 \text{ m}^2$

Sporządził: