

# PRZEKROJE POPRZECZNE DROGI WOJEWÓDZKIEJ NR 651 OD KM 69+079 DO KM 70+220

SKALA 1:10/100

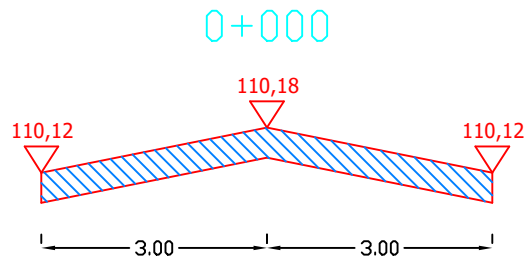

Pwyr.=0,0000 m<sup>2</sup>

Pfrez.=0,2400 m<sup>2</sup>

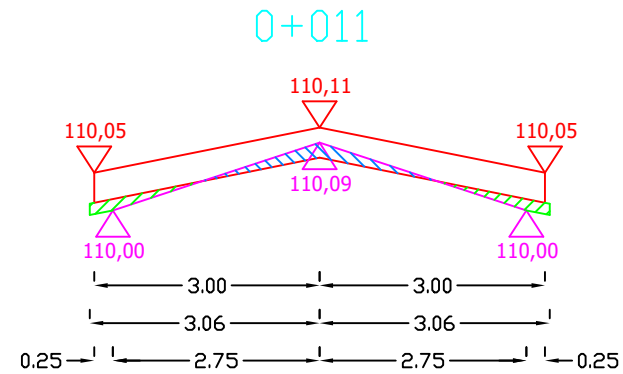

Pwyr.=0,0270 m<sup>2</sup>

Pfrez.=0,0314 m<sup>2</sup>

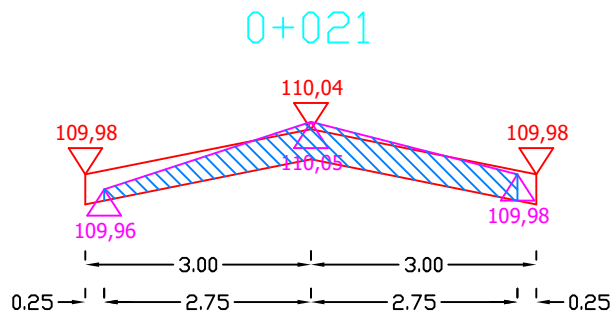

Pwyr.=0,0000 m<sup>2</sup>

Pfrez.=0,2063 m<sup>2</sup>

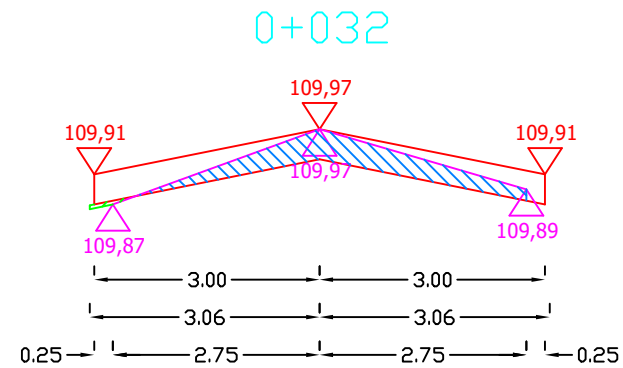

Pwyr.=0,0023 m<sup>2</sup>

Pfrez.=0,1245 m<sup>2</sup>

Sporządził:

PRZEKROJE POPRZECZNE DROGI WOJEWÓDZKIEJ NR 651 OD KM 69+079 DO KM 70+220

SKALA 1:10/100

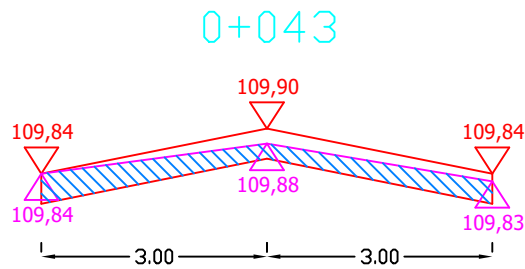

Pwyr.=0,0000 m<sup>2</sup>

Pfrez.=0,1650 m<sup>2</sup>

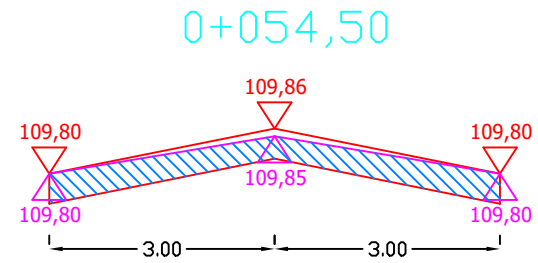

Pwyr.=0,0000 m<sup>2</sup>

Pfrez.=0,2100 m<sup>2</sup>

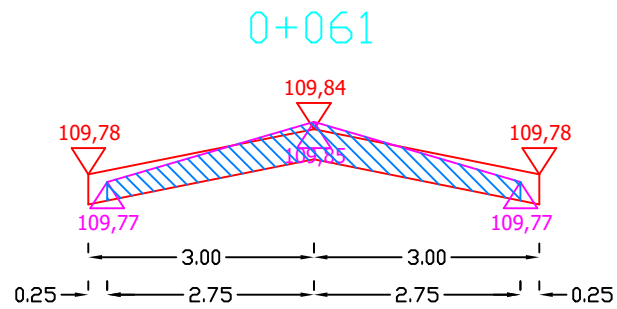

Pwyr.=0,0000 m<sup>2</sup>

Pfrez.=0,2063 m<sup>2</sup>

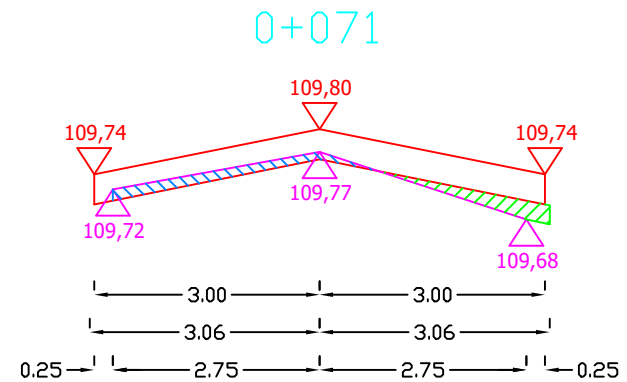

Pwyr.=0,0323 m<sup>2</sup>

Pfrez.=0,0383 m<sup>2</sup>

Sporządził:

# PRZEKROJE POPRZECZNE DROGI WOJEWÓDZKIEJ NR 651 OD KM 69+079 DO KM 70+220

SKALA 1:10/100

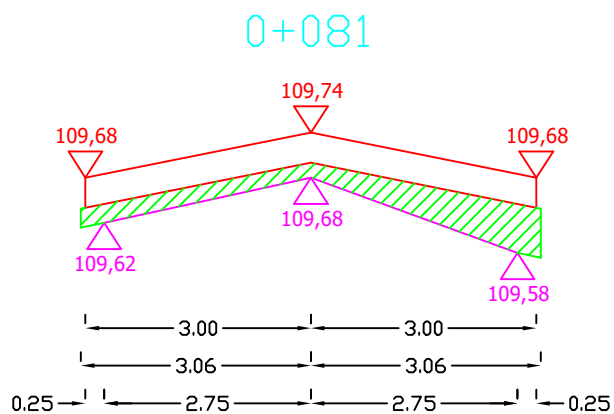

Pwyr.=0,2067 m<sup>2</sup>

Pfrez.=0,0000 m<sup>2</sup>

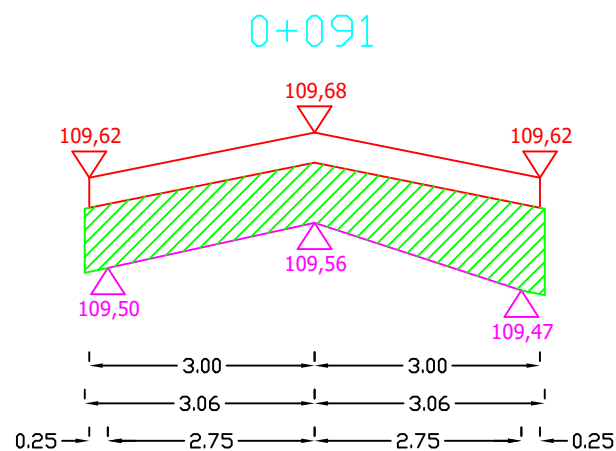

Pwyr.=0,5570 m<sup>2</sup>

Pfrez.=0,0000 m<sup>2</sup>

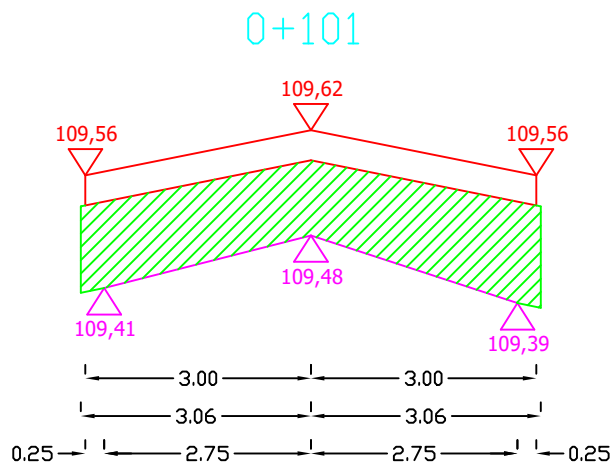

Pwyr.=0,6963 m<sup>2</sup>

Pfrez.=0,0000 m<sup>2</sup>

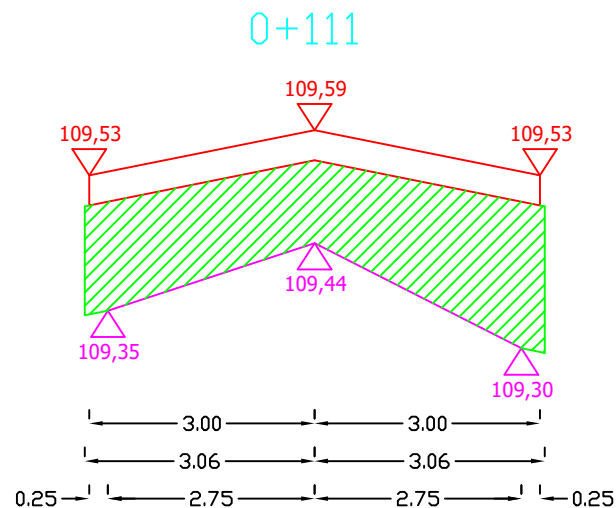

Pwyr.=0,8754 m<sup>2</sup>

Pfrez.=0,0000 m<sup>2</sup>

Sporządził:

PRZEKROJE POPRZECZNE DROGI WOJEWÓDZKIEJ NR 651 OD KM 69+079 DO KM 70+220

SKALA 1:10/100

0+121

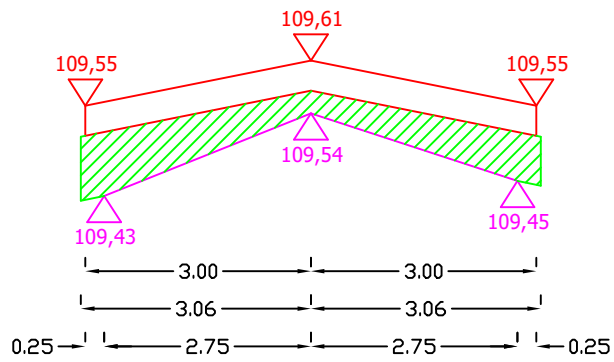

Pwyr.=0,3353 m<sup>2</sup>

Pfrez.=0,0000 m<sup>2</sup>

0+131

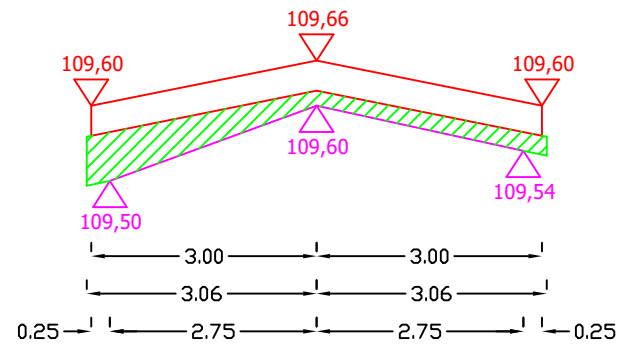

Pwyr.=0,2067 m<sup>2</sup>

Pfrez.=0,0000 m<sup>2</sup>

0+141

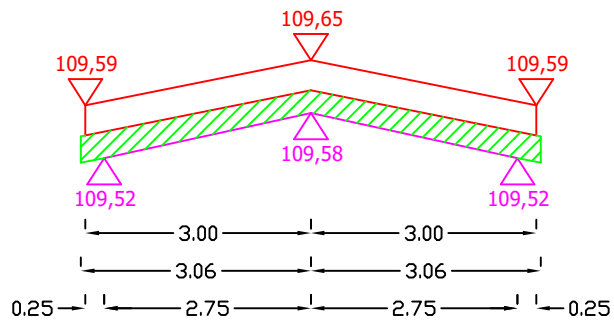

Pwyr.=0,2005 m<sup>2</sup>

Pfrez.=0,0000 m<sup>2</sup>

0+151

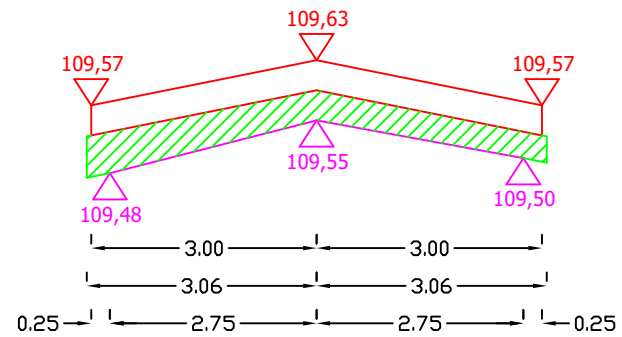

Pwyr.=0,2617 m<sup>2</sup>

Pfrez.=0,0000 m<sup>2</sup>

Sporządził:

PRZEKROJE POPRZECZNE DROGI WOJEWÓDZKIEJ NR 651 OD KM 69+079 DO KM 70+220

SKALA 1:10/100

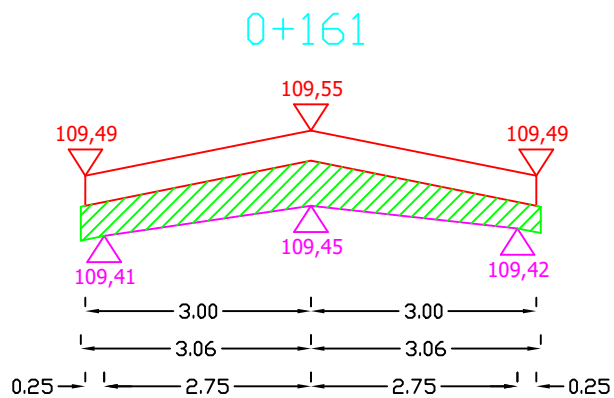

Pwyr.=0,2998 m<sup>2</sup>

Pfrez.=0,0000 m<sup>2</sup>

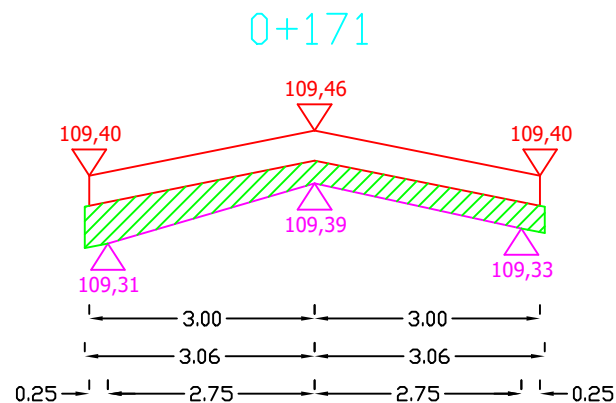

Pwyr.=0,2342 m<sup>2</sup>

Pfrez.=0,0000 m<sup>2</sup>

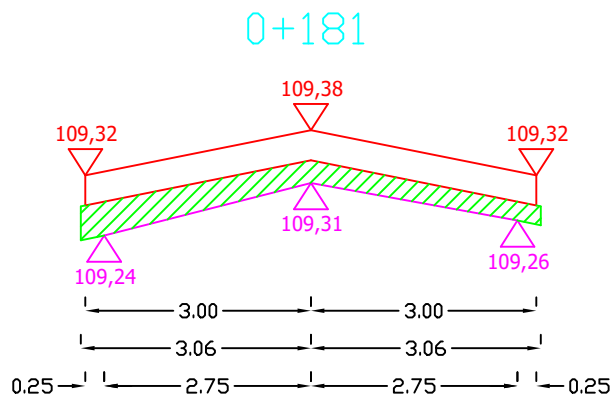

Pwyr.=0,2005 m<sup>2</sup>

Pfrez.=0,0000 m<sup>2</sup>

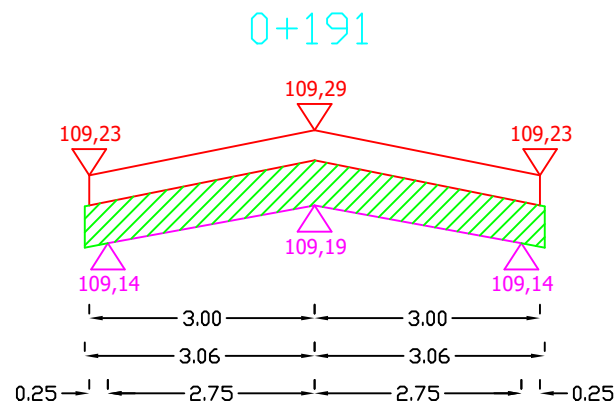

Pwyr.=0,3504 m<sup>2</sup>

Pfrez.=0,0000 m<sup>2</sup>

Sporządził:

# PRZEKROJE POPRZECZNE DROGI WOJEWÓDZKIEJ NR 651 OD KM 69+079 DO KM 70+220

SKALA 1:10/100

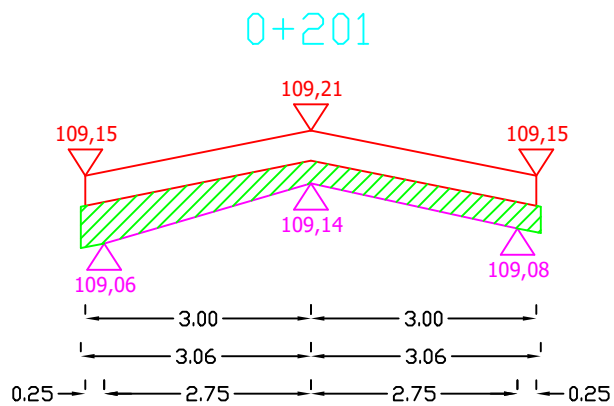

Pwyr.=0,2342 m<sup>2</sup>

Pfrez.=0,0000 m<sup>2</sup>

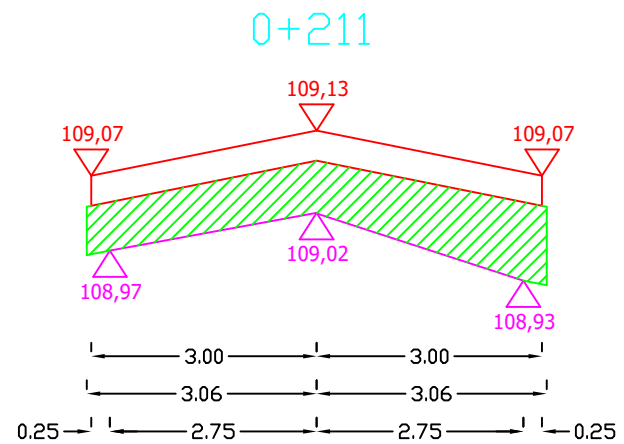

Pwyr.=0,4757 m<sup>2</sup>

Pfrez.=0,0000 m<sup>2</sup>

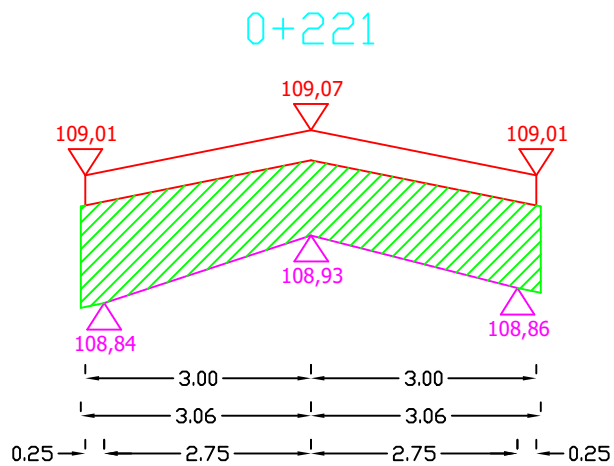

Pwyr.=0,6963 m<sup>2</sup>

Pfrez.=0,0000 m<sup>2</sup>

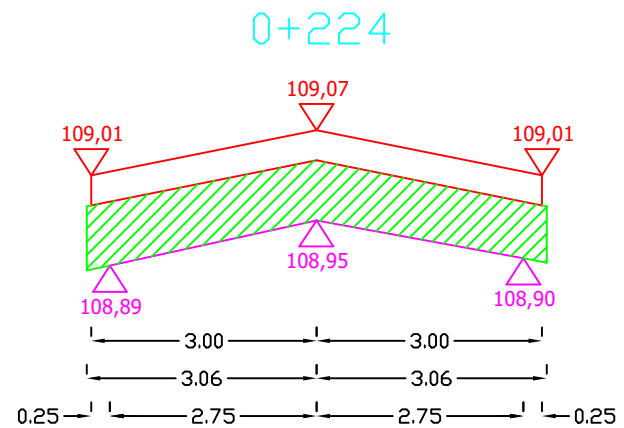

Pwyr.=0,4896 m<sup>2</sup>

Pfrez.=0,0000 m<sup>2</sup>

Sporządził:

# PRZEKROJE POPRZECZNE DROGI WOJEWÓDZKIEJ NR 651 OD KM 69+079 DO KM 70+220

SKALA 1:10/100

0+231

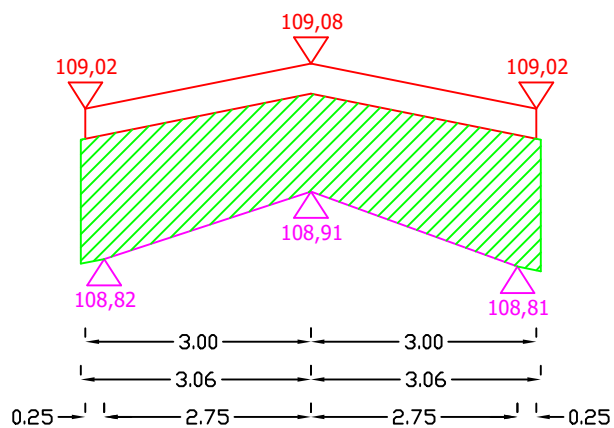

Pwyr.=0,9304 m<sup>2</sup>

Pfrez.=0,0000 m<sup>2</sup>

0+241

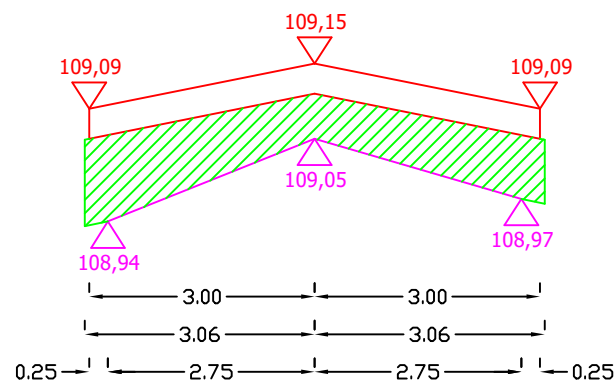

Pwyr.=0,5020 m<sup>2</sup>

Pfrez.=0,0000 m<sup>2</sup>

0+251

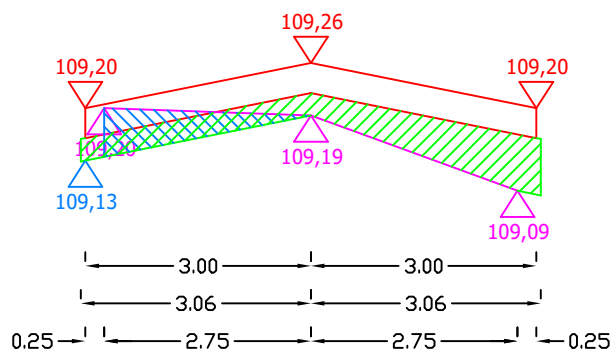

Pwyr.=0,2594 m<sup>2</sup>

Pfrez.=0,0894 m<sup>2</sup>

0+261

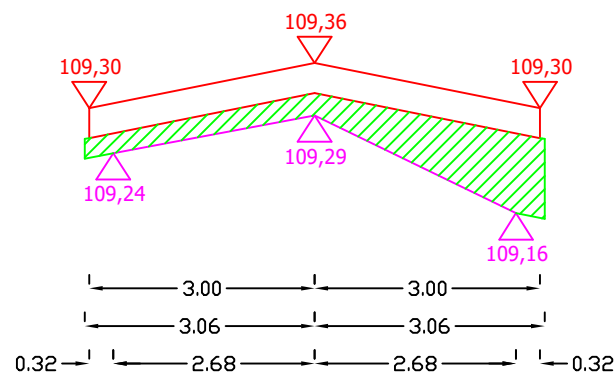

Pwyr.=0,3088 m<sup>2</sup>

Pfrez.=0,0000 m<sup>2</sup>

Sporządził:

# PRZEKROJE POPRZECZNE DROGI WOJEWÓDZKIEJ NR 651 OD KM 69+079 DO KM 70+220

SKALA 1:10/100

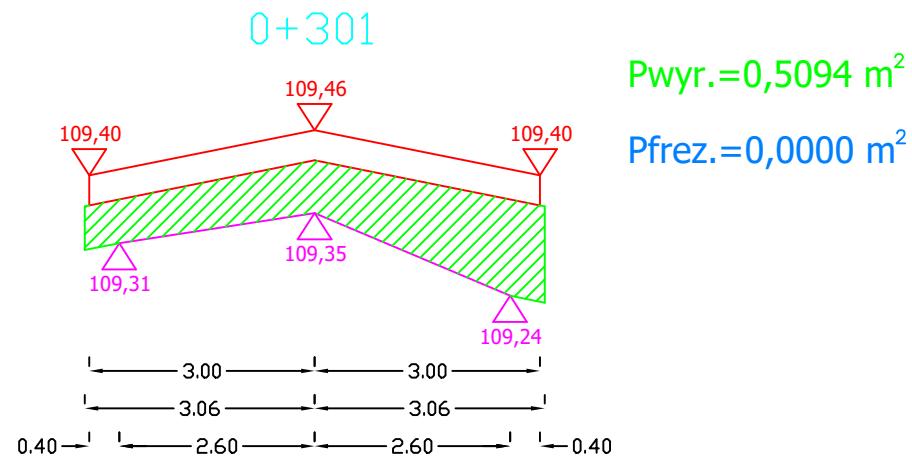
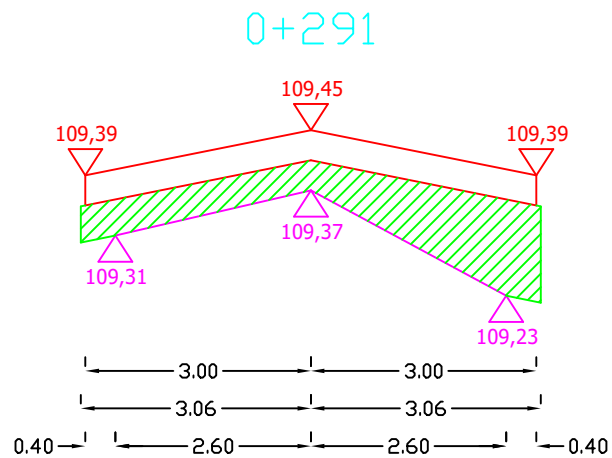
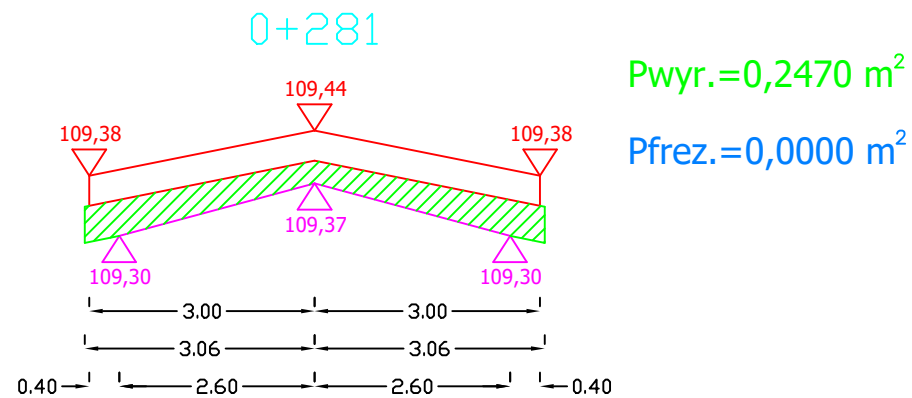
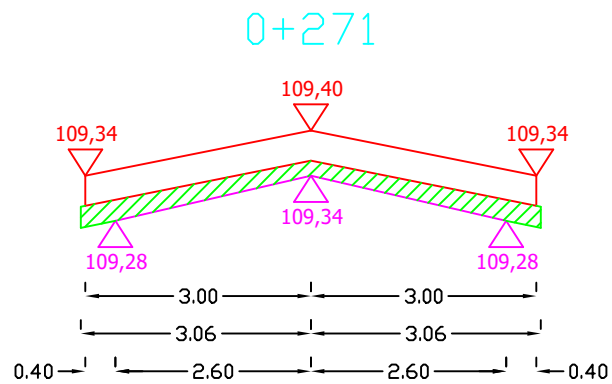

Sporządził:



# PRZEKROJE POPRZECZNE DROGI WOJEWÓDZKIEJ NR 651 OD KM 69+079 DO KM 70+220

SKALA 1:10/100

0+311

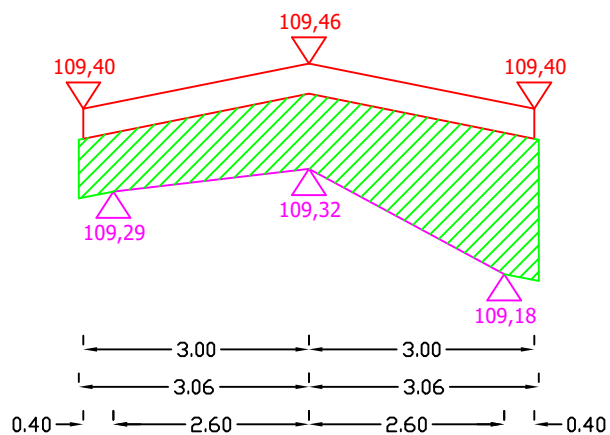

Pwyr.=0,7282 m<sup>2</sup>

Pfrez.=0,0000 m<sup>2</sup>

0+321

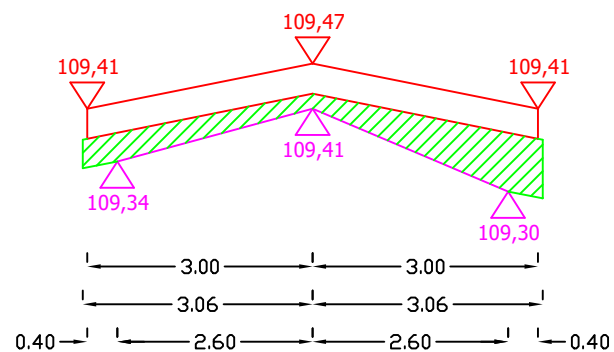

Pwyr.=0,2562 m<sup>2</sup>

Pfrez.=0,0000 m<sup>2</sup>

0+331

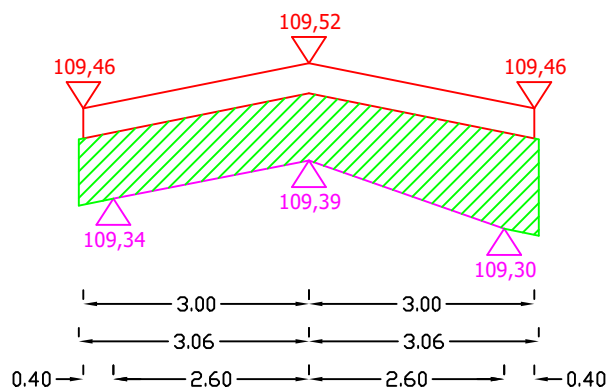

Pwyr.=0,6128 m<sup>2</sup>

Pfrez.=0,0000 m<sup>2</sup>

0+341

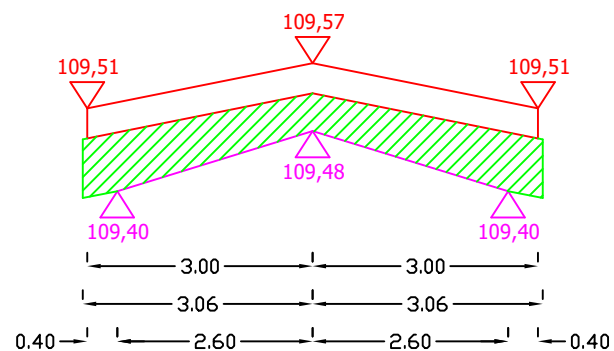

Pwyr.=0,4046 m<sup>2</sup>

Pfrez.=0,0000 m<sup>2</sup>

Sporządził:

# PRZEKROJE POPRZECZNE DROGI WOJEWÓDZKIEJ NR 651 OD KM 69+079 DO KM 70+220

SKALA 1:10/100

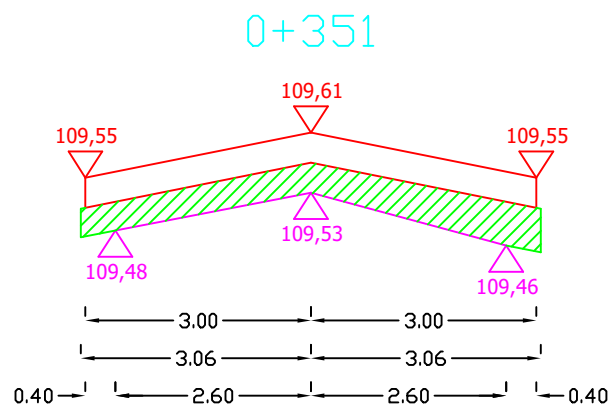

Pwyr.=0,2730 m<sup>2</sup>

Pfrez.=0,0000 m<sup>2</sup>

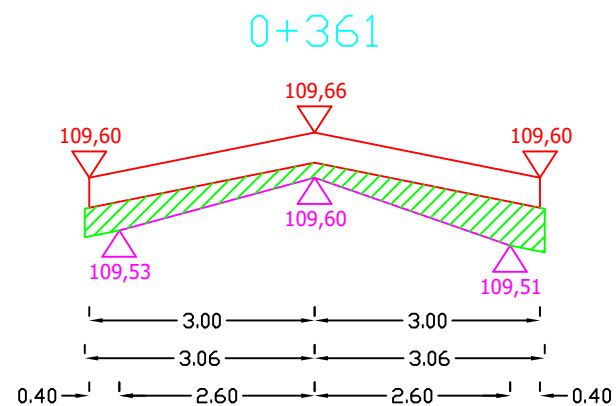

Pwyr.=0,2210 m<sup>2</sup>

Pfrez.=0,0000 m<sup>2</sup>

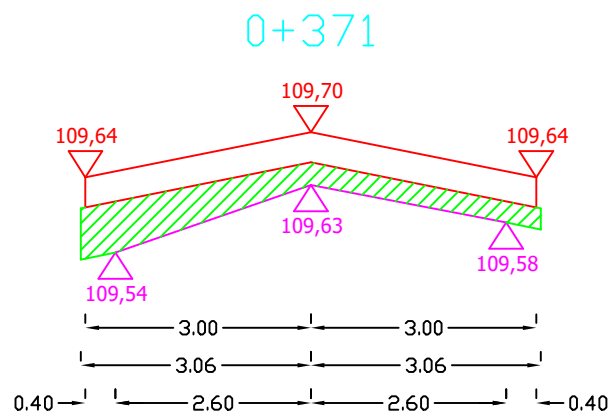

Pwyr.=0,2470 m<sup>2</sup>

Pfrez.=0,0000 m<sup>2</sup>

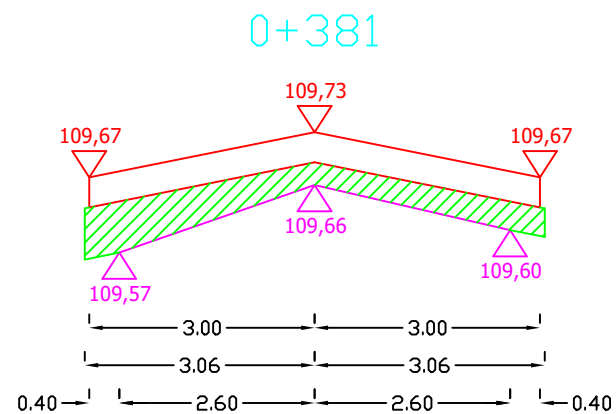

Pwyr.=0,2646 m<sup>2</sup>

Pfrez.=0,0000 m<sup>2</sup>

Sporządził:

# PRZEKROJE POPRZECZNE DROGI WOJEWÓDZKIEJ NR 651 OD KM 69+079 DO KM 70+220

SKALA 1:10/100

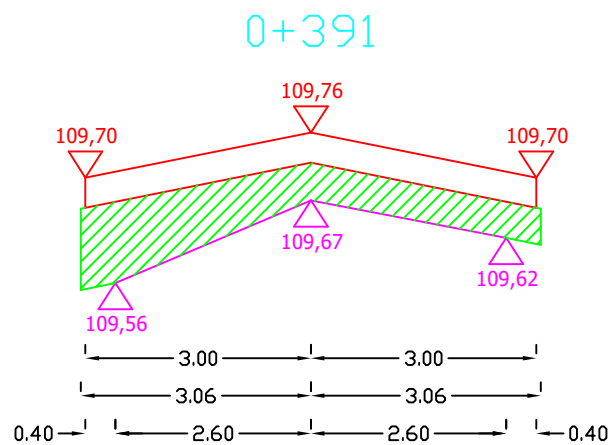

Pwyr.=0,4046 m<sup>2</sup>

Pfrez.=0,0000 m<sup>2</sup>

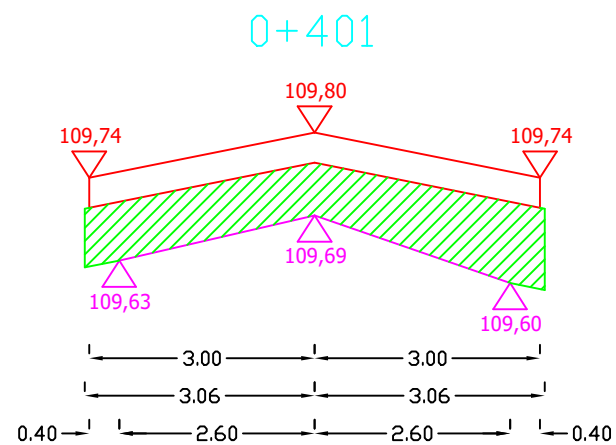

Pwyr.=0,5094 m<sup>2</sup>

Pfrez.=0,0000 m<sup>2</sup>

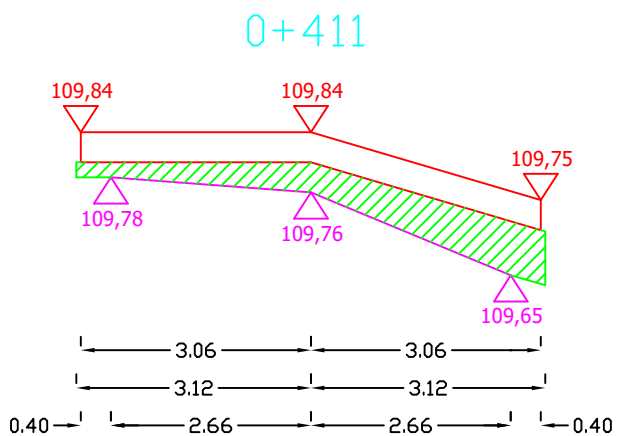

Pwyr.=0,2707 m<sup>2</sup>

Pfrez.=0,0000 m<sup>2</sup>

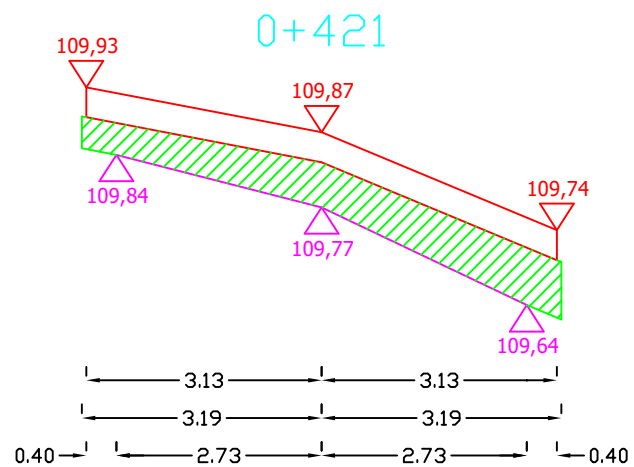

Pwyr.=0,3809 m<sup>2</sup>

Pfrez.=0,0000 m<sup>2</sup>

Sporządził:

# PRZEKROJE POPRZECZNE DROGI WOJEWÓDZKIEJ NR 651 OD KM 69+079 DO KM 70+220

SKALA 1:10/100

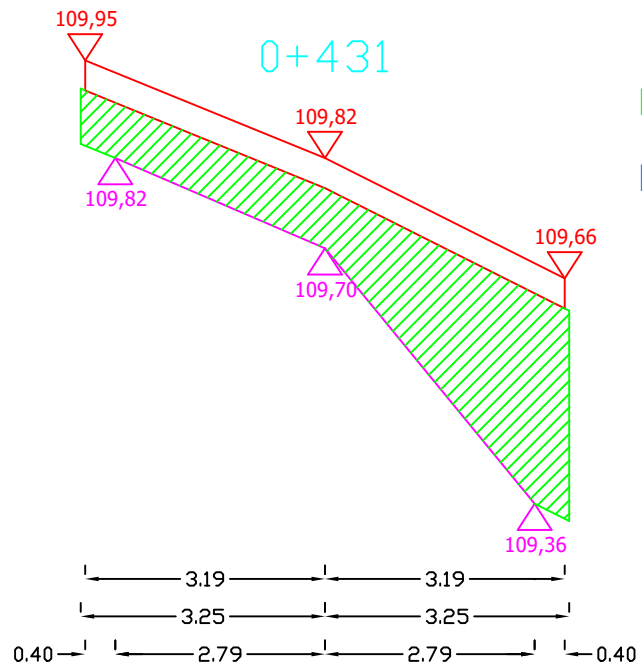

Pwyr.=0,8794 m<sup>2</sup>  
Pfrez.=0,0000 m<sup>2</sup>

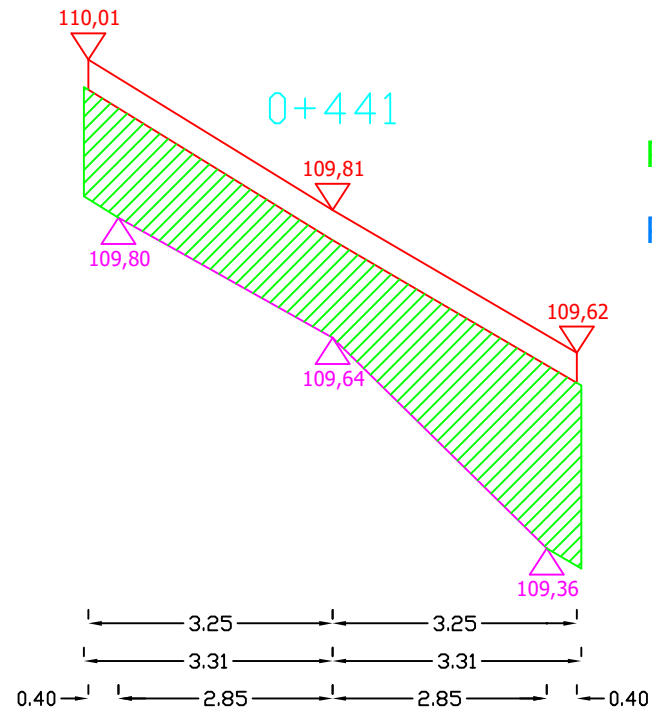

Pwyr.=1,1033 m<sup>2</sup>  
Pfrez.=0,0000 m<sup>2</sup>

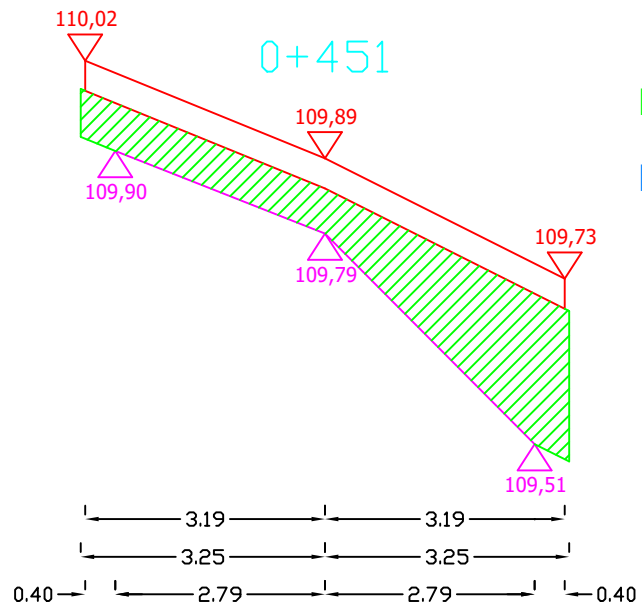

Pwyr.=0,6567 m<sup>2</sup>  
Pfrez.=0,0000 m<sup>2</sup>

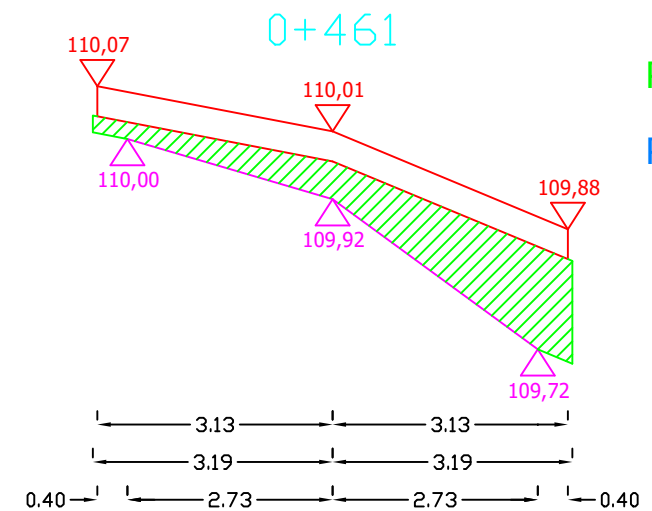

Pwyr.=0,4266 m<sup>2</sup>  
Pfrez.=0,0000 m<sup>2</sup>

Sporządził:

# PRZEKROJE POPRZECZNE DROGI WOJEWÓDZKIEJ NR 651 OD KM 69+079 DO KM 70+220

SKALA 1:10/100

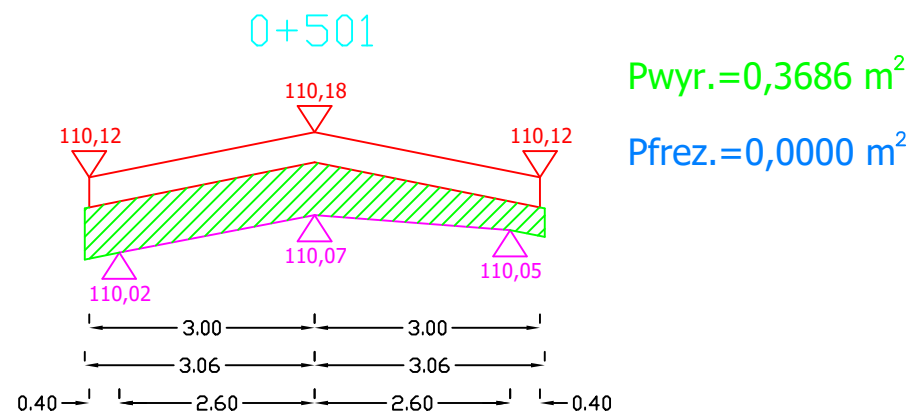
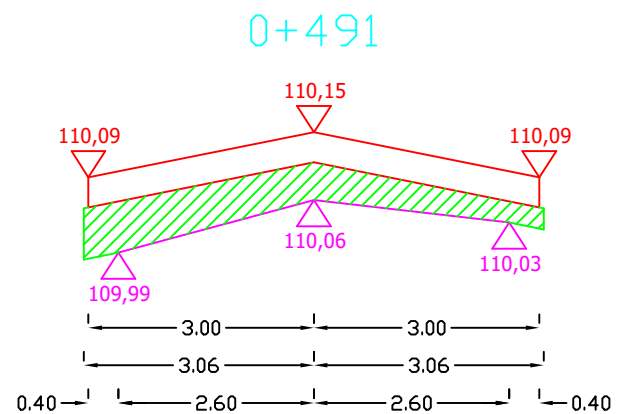
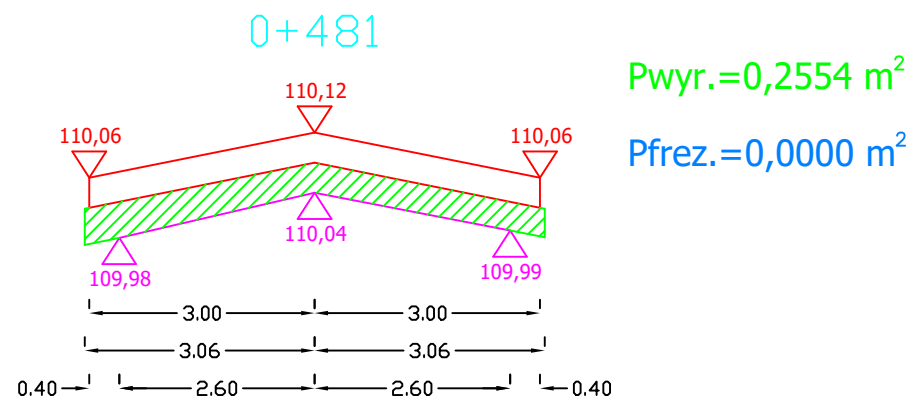
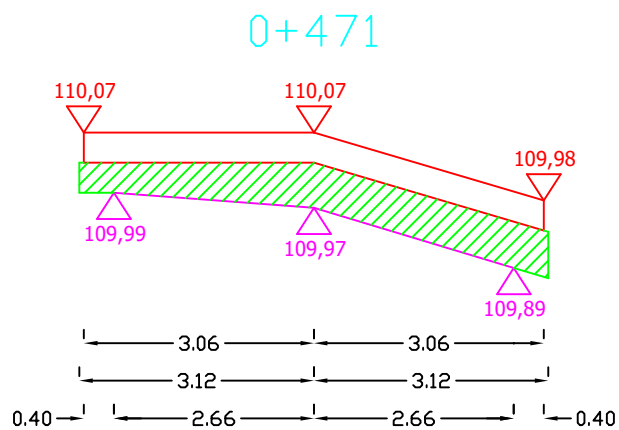

Sporządził:

# PRZEKROJE POPRZECZNE DROGI WOJEWÓDZKIEJ NR 651 OD KM 69+079 DO KM 70+220

SKALA 1:10/100

0+511

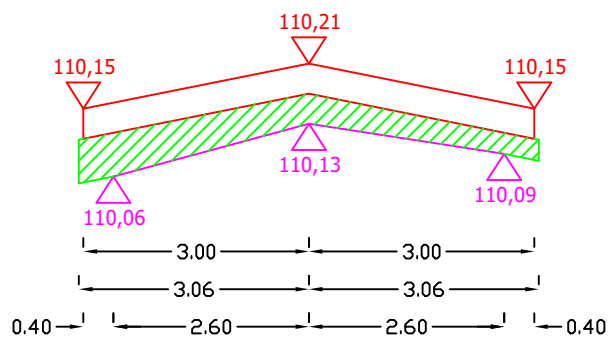

Pwyr.=0,2554 m<sup>2</sup>

Pfrez.=0,0000 m<sup>2</sup>

0+521

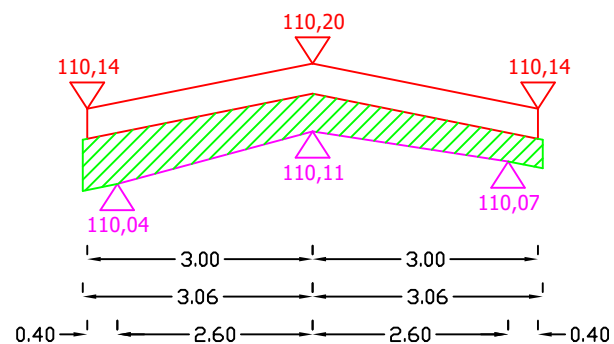

Pwyr.=0,3166 m<sup>2</sup>

Pfrez.=0,0000 m<sup>2</sup>

0+531

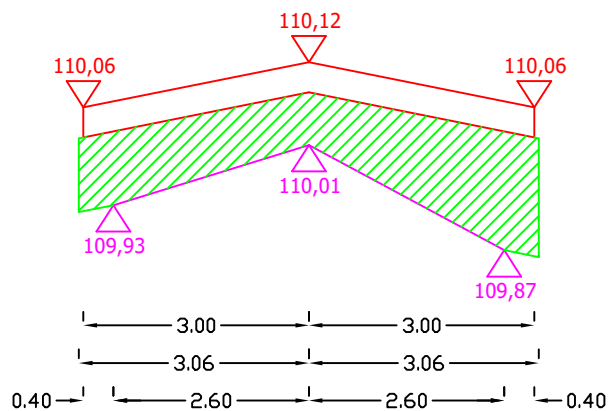

Pwyr.=0,6326 m<sup>2</sup>

Pfrez.=0,0000 m<sup>2</sup>

0+541

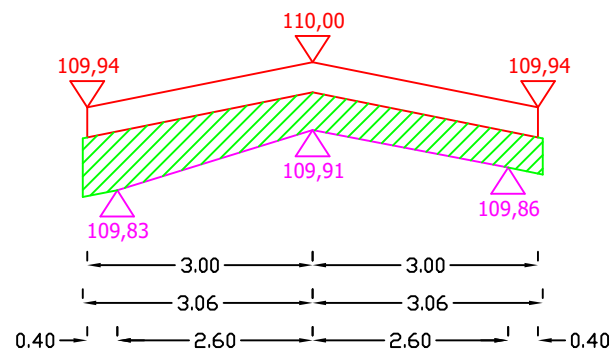

Pwyr.=0,3518 m<sup>2</sup>

Pfrez.=0,0000 m<sup>2</sup>

Sporządził:

# PRZEKROJE POPRZECZNE DROGI WOJEWÓDZKIEJ NR 651 OD KM 69+079 DO KM 70+220

SKALA 1:10/100

0+551

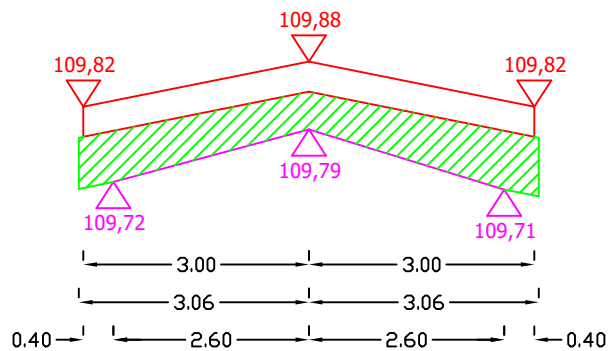

Pwyr.=0,3870 m<sup>2</sup>

Pfrez.=0,0000 m<sup>2</sup>

0+561

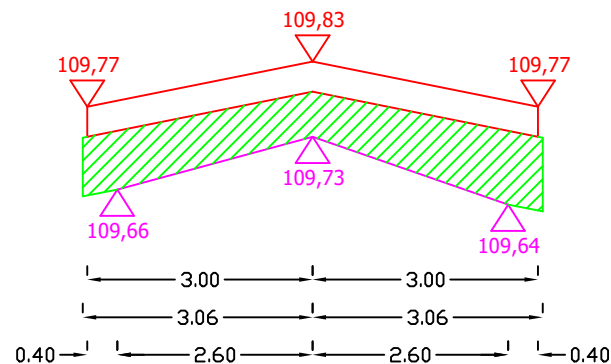

Pwyr.=0,4658 m<sup>2</sup>

Pfrez.=0,0000 m<sup>2</sup>

0+571

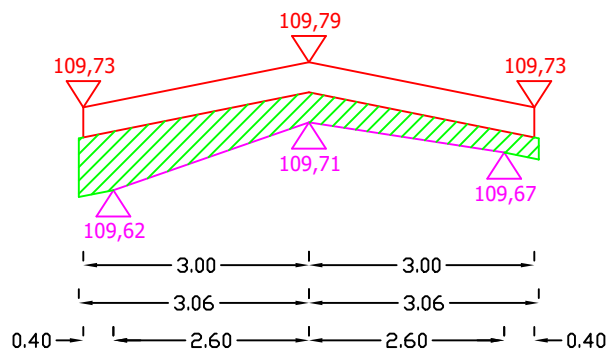

Pwyr.=0,2906 m<sup>2</sup>

Pfrez.=0,0000 m<sup>2</sup>

0+581

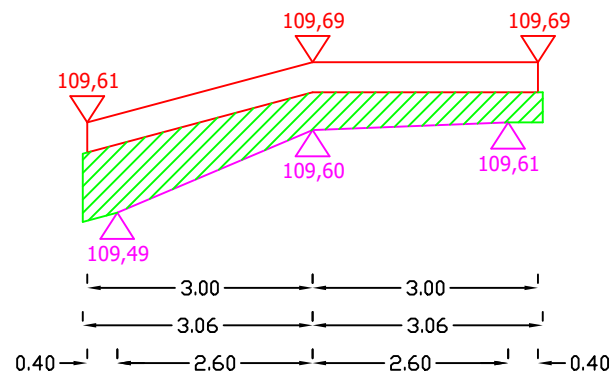

Pwyr.=0,3600 m<sup>2</sup>

Pfrez.=0,0000 m<sup>2</sup>

Sporządził:

# PRZEKROJE POPRZECZNE DROGI WOJEWÓDZKIEJ NR 651 OD KM 69+079 DO KM 70+220

SKALA 1:10/100

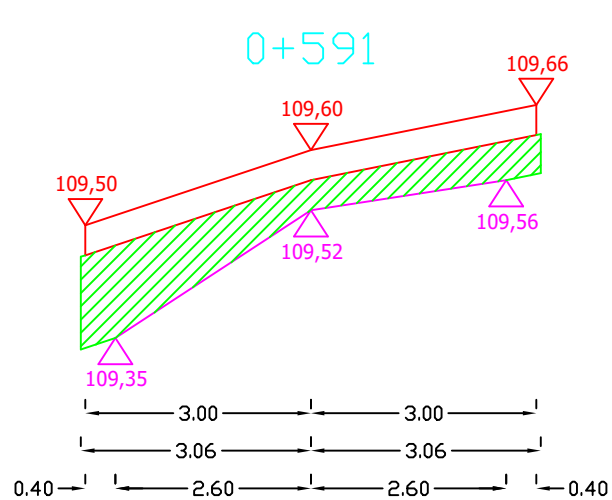

Pwyr.=0,4126 m<sup>2</sup>

Pfrez.=0,0000 m<sup>2</sup>

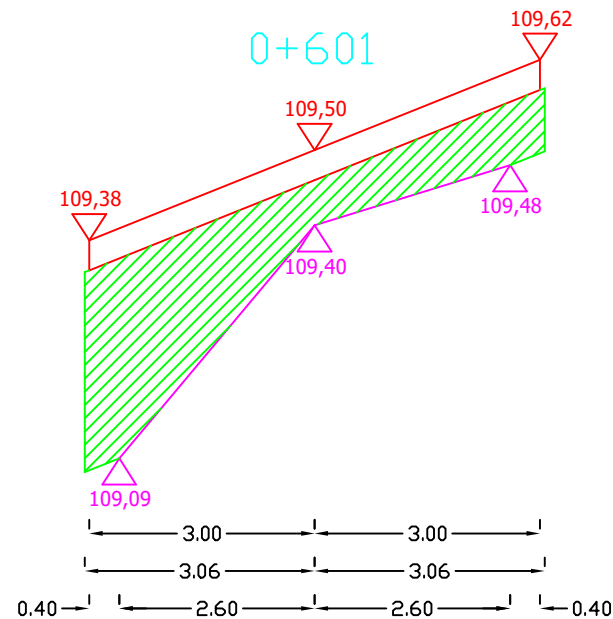

Pwyr.=0,7720 m<sup>2</sup>

Pfrez.=0,0000 m<sup>2</sup>

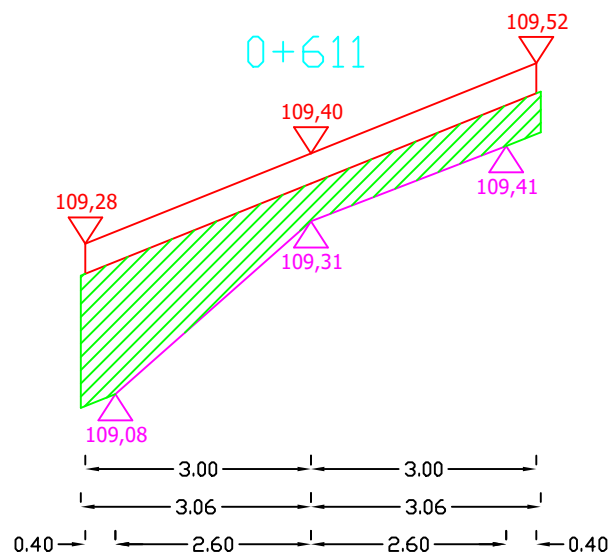

Pwyr.=0,5348 m<sup>2</sup>

Pfrez.=0,0000 m<sup>2</sup>

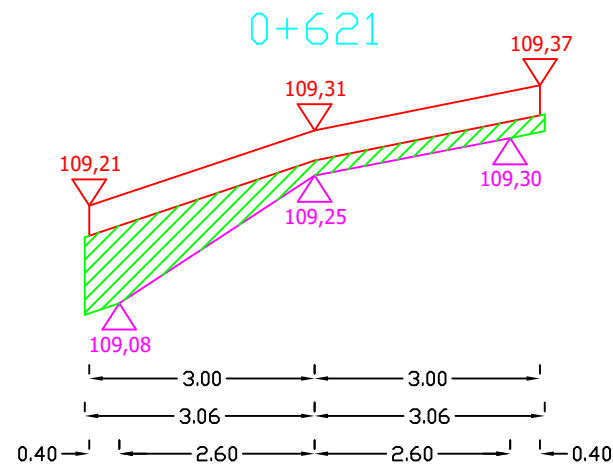

Pwyr.=0,2726 m<sup>2</sup>

Pfrez.=0,0000 m<sup>2</sup>

Sporządził:



# PRZEKROJE POPRZECZNE DROGI WOJEWÓDZKIEJ NR 651 OD KM 69+079 DO KM 70+220

SKALA 1:10/100

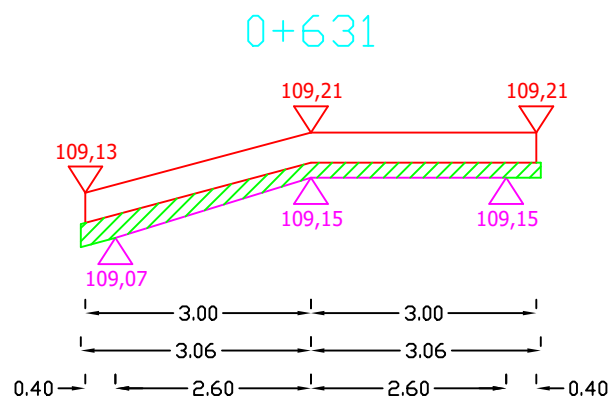

Pwyr.=0,1412 m<sup>2</sup>

Pfrez.=0,0000 m<sup>2</sup>

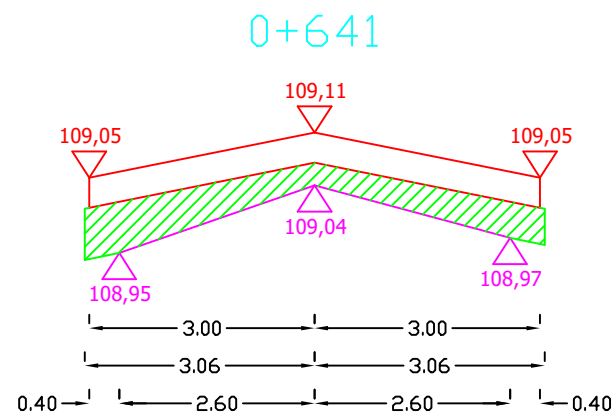

Pwyr.=0,2822 m<sup>2</sup>

Pfrez.=0,0000 m<sup>2</sup>

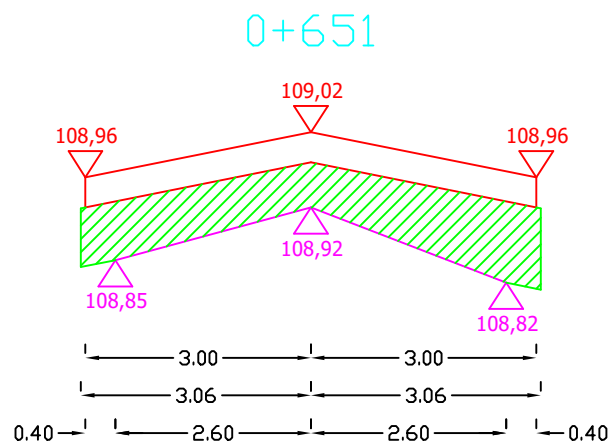

Pwyr.=0,4834 m<sup>2</sup>

Pfrez.=0,0000 m<sup>2</sup>

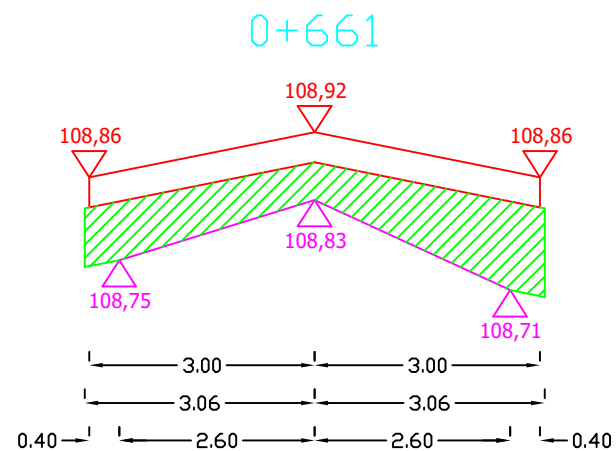

Pwyr.=0,4749 m<sup>2</sup>

Pfrez.=0,0000 m<sup>2</sup>

Sporządził:

# PRZEKROJE POPRZECZNE DROGI WOJEWÓDZKIEJ NR 651 OD KM 69+079 DO KM 70+220

SKALA 1:10/100

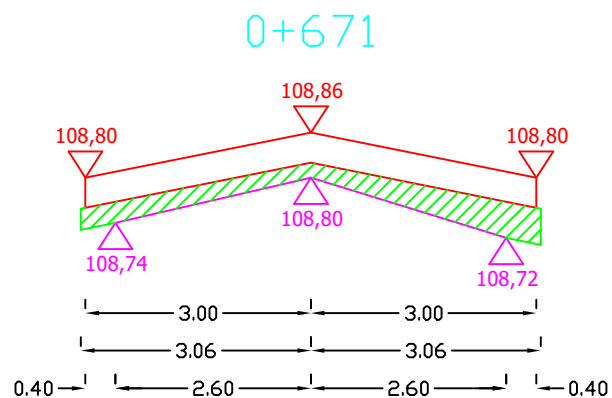

Pwyr.=0,1858 m<sup>2</sup>

Pfrez.=0,0000 m<sup>2</sup>

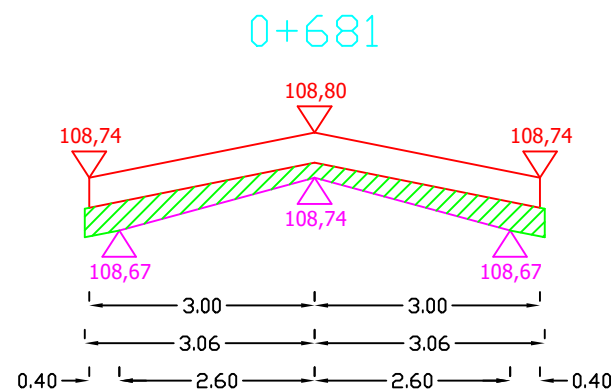

Pwyr.=0,1858 m<sup>2</sup>

Pfrez.=0,0000 m<sup>2</sup>

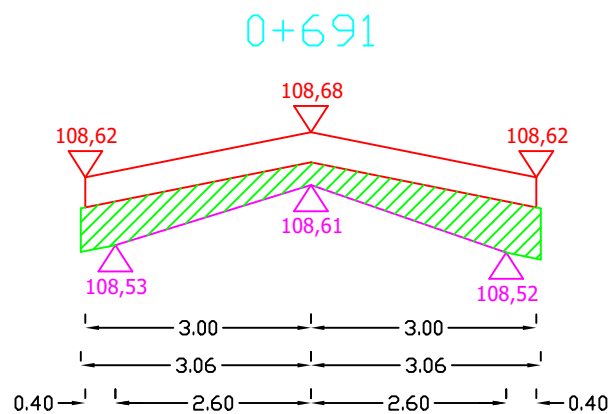

Pwyr.=0,2998 m<sup>2</sup>

Pfrez.=0,0000 m<sup>2</sup>

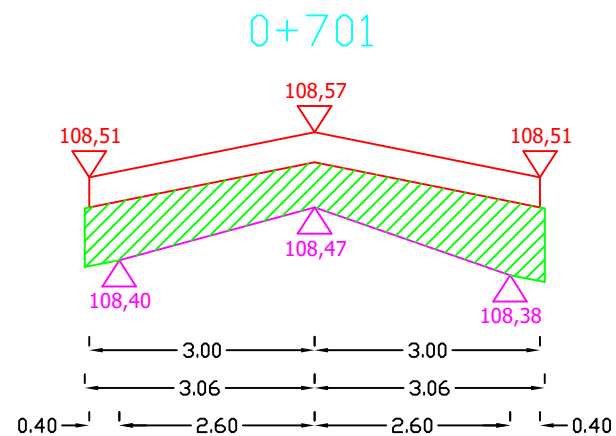

Pwyr.=0,4658 m<sup>2</sup>

Pfrez.=0,0000 m<sup>2</sup>

Sporządził:

# PRZEKROJE POPRZECZNE DROGI WOJEWÓDZKIEJ NR 651 OD KM 69+079 DO KM 70+220

SKALA 1:10/100

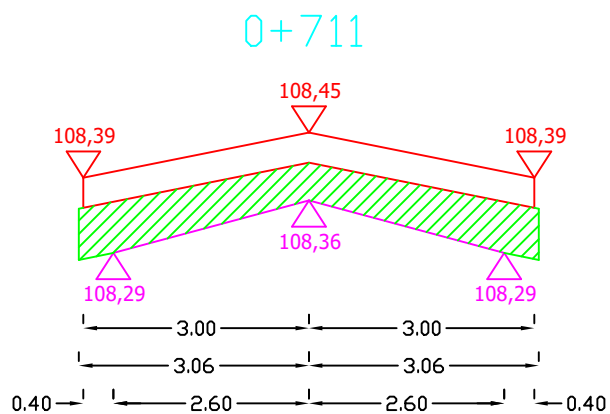

Pwyr.=0,3694 m<sup>2</sup>

Pfrez.=0,0000 m<sup>2</sup>

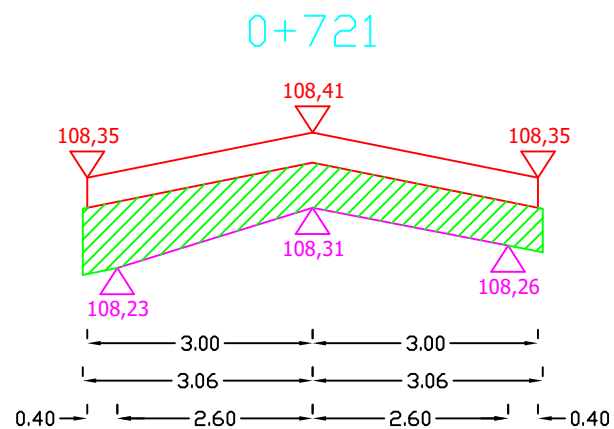

Pwyr.=0,4130 m<sup>2</sup>

Pfrez.=0,0000 m<sup>2</sup>

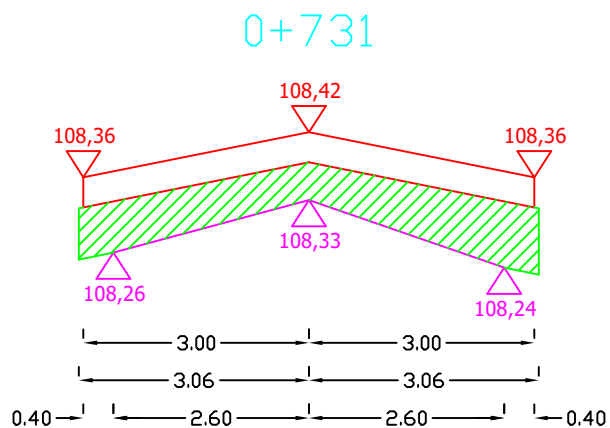

Pwyr.=0,4046 m<sup>2</sup>

Pfrez.=0,0000 m<sup>2</sup>

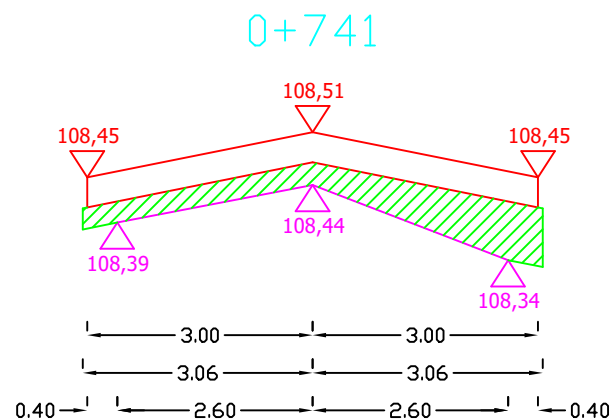

Pwyr.=0,2646 m<sup>2</sup>

Pfrez.=0,0000 m<sup>2</sup>

Sporządził:

# PRZEKROJE POPRZECZNE DROGI WOJEWÓDZKIEJ NR 651 OD KM 69+079 DO KM 70+220

SKALA 1:10/100

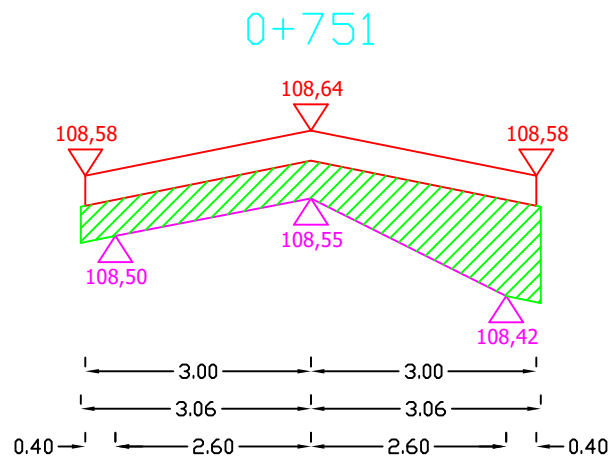

Pwyr.=0,4398 m<sup>2</sup>

Pfrez.=0,0000 m<sup>2</sup>

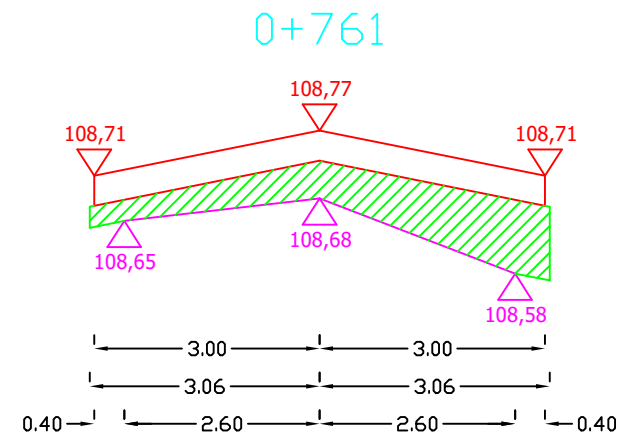

Pwyr.=0,3518 m<sup>2</sup>

Pfrez.=0,0000 m<sup>2</sup>

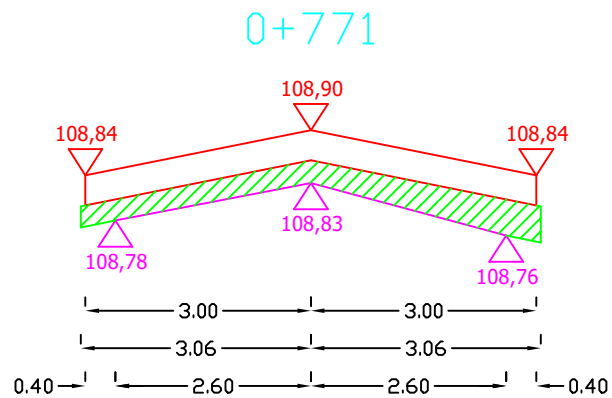

Pwyr.=0,2118 m<sup>2</sup>

Pfrez.=0,0000 m<sup>2</sup>

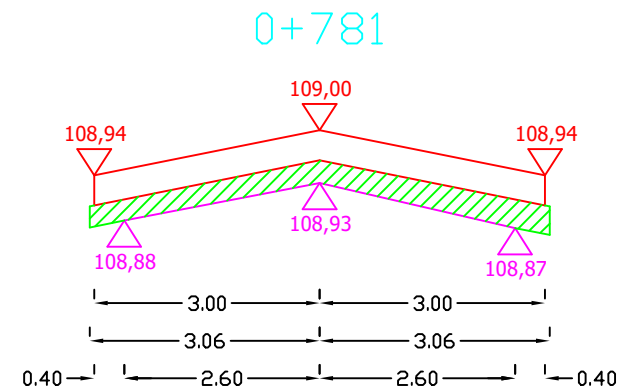

Pwyr.=0,1942 m<sup>2</sup>

Pfrez.=0,0000 m<sup>2</sup>

Sporządził:

PRZEKROJE POPRZECZNE DROGI WOJEWÓDZKIEJ NR 651 OD KM 69+079 DO KM 70+220

SKALA 1:10/100

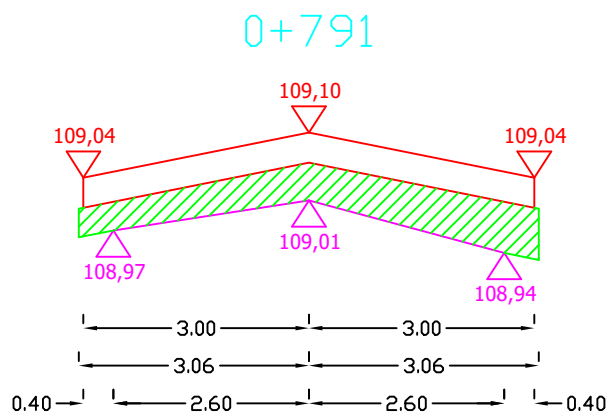

Pwyr.=0,3166 m<sup>2</sup>

Pfrez.=0,0000 m<sup>2</sup>

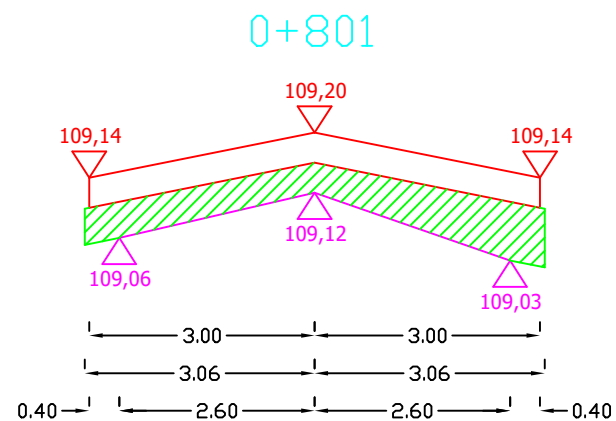

Pwyr.=0,3258 m<sup>2</sup>

Pfrez.=0,0000 m<sup>2</sup>

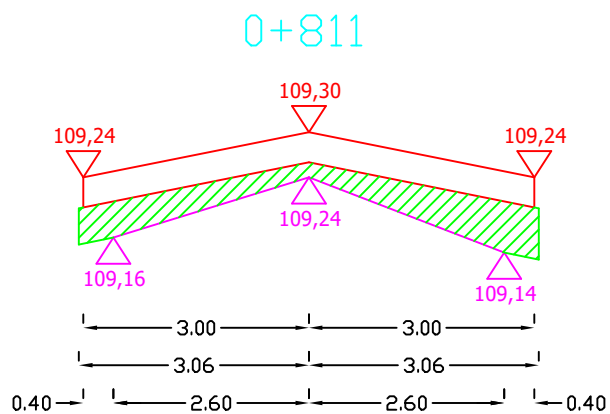

Pwyr.=0,2562 m<sup>2</sup>

Pfrez.=0,0000 m<sup>2</sup>

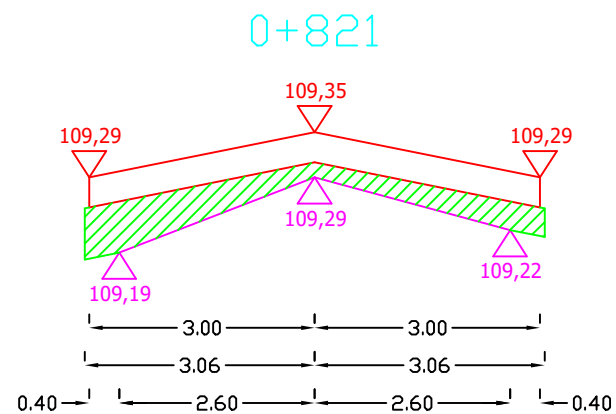

Pwyr.=0,2386 m<sup>2</sup>

Pfrez.=0,0000 m<sup>2</sup>

Sporządził:

# PRZEKROJE POPRZECZNE DROGI WOJEWÓDZKIEJ NR 651 OD KM 69+079 DO KM 70+220

SKALA 1:10/100

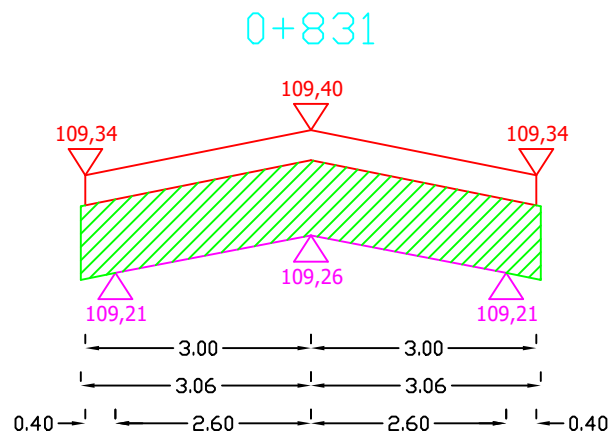

Pwyr.=0,6050 m<sup>2</sup>

Pfrez.=0,0000 m<sup>2</sup>

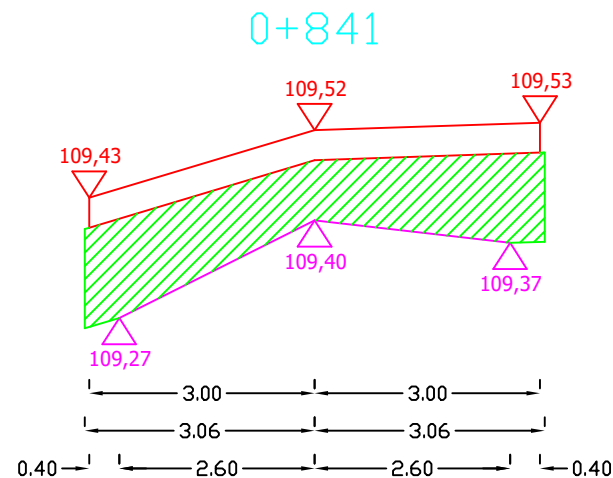

Pwyr.=0,6492 m<sup>2</sup>

Pfrez.=0,0000 m<sup>2</sup>

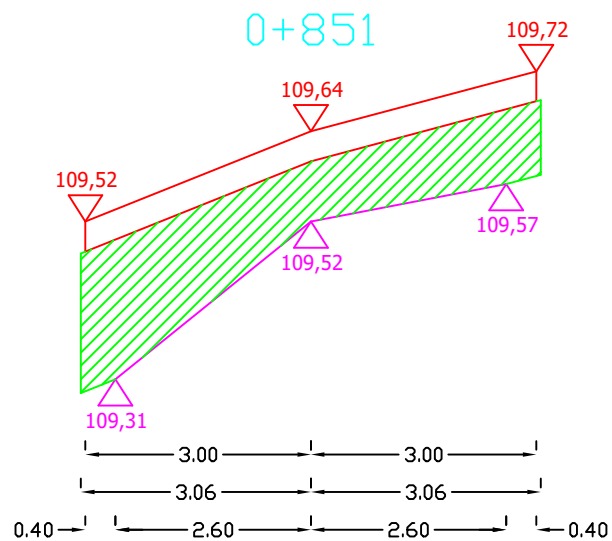

Pwyr.=0,7102 m<sup>2</sup>

Pfrez.=0,0000 m<sup>2</sup>

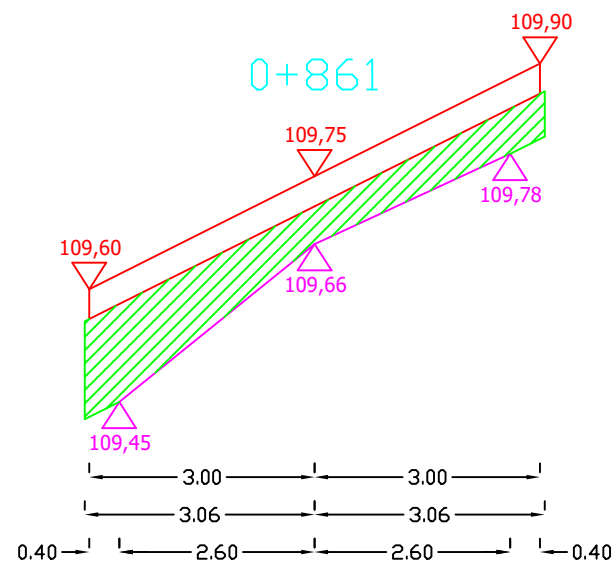

Pwyr.=0,4644 m<sup>2</sup>

Pfrez.=0,0000 m<sup>2</sup>

Sporządził:

# PRZEKROJE POPRZECZNE DROGI WOJEWÓDZKIEJ NR 651 OD KM 69+079 DO KM 70+220

SKALA 1:10/100

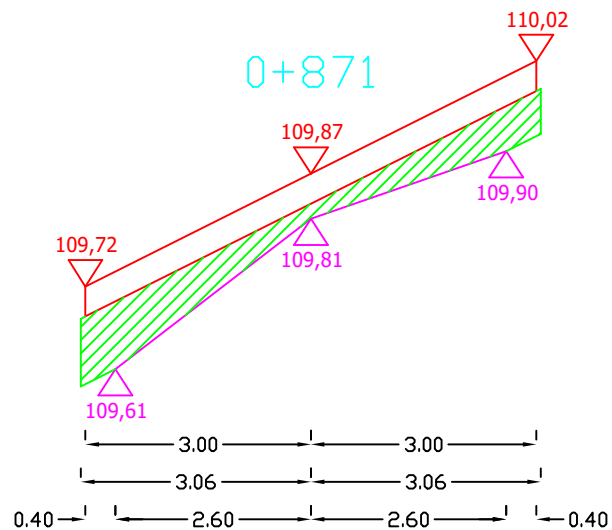

Pwyr.=0,3160 m<sup>2</sup>

Pfrez.=0,0000 m<sup>2</sup>

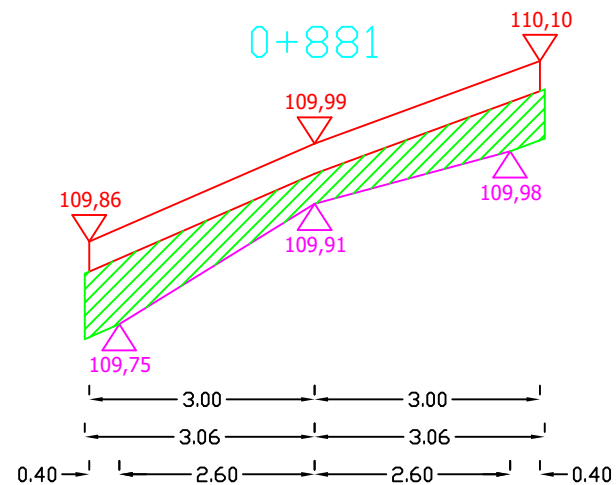

Pwyr.=0,3727 m<sup>2</sup>

Pfrez.=0,0000 m<sup>2</sup>

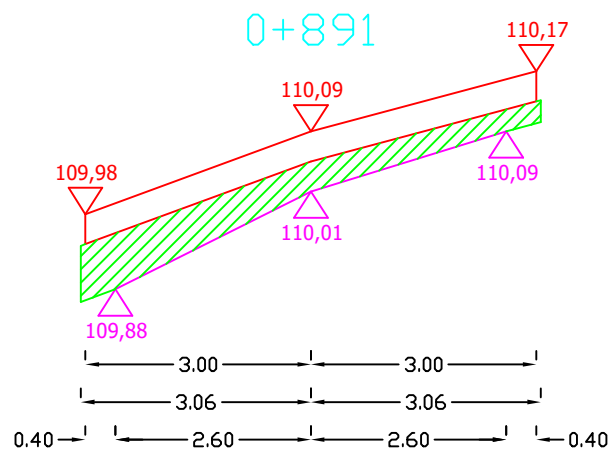

Pwyr.=0,2870 m<sup>2</sup>

Pfrez.=0,0000 m<sup>2</sup>

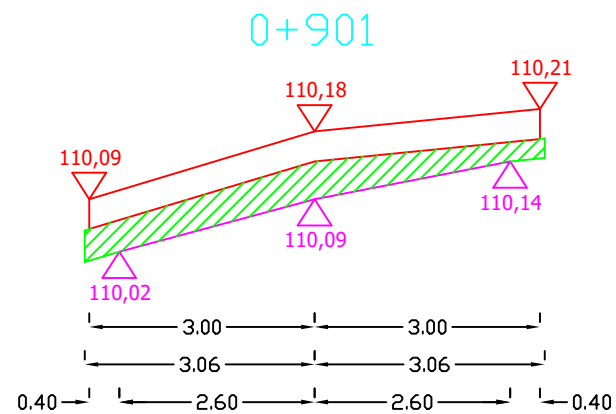

Pwyr.=0,2497 m<sup>2</sup>

Pfrez.=0,0000 m<sup>2</sup>

Sporządził:

# PRZEKROJE POPRZECZNE DROGI WOJEWÓDZKIEJ NR 651 OD KM 69+079 DO KM 70+220

SKALA 1:10/100

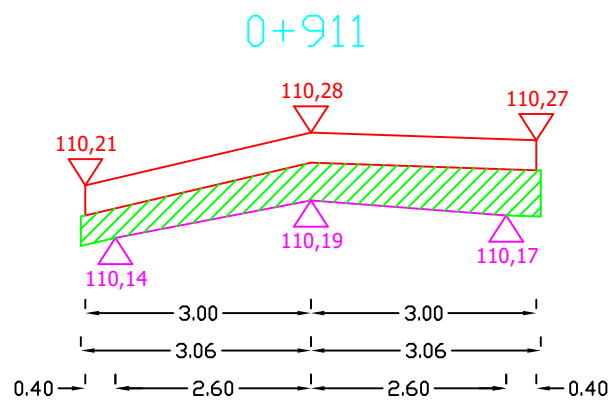

Pwyr.=0,3072 m<sup>2</sup>

Pfrez.=0,0000 m<sup>2</sup>

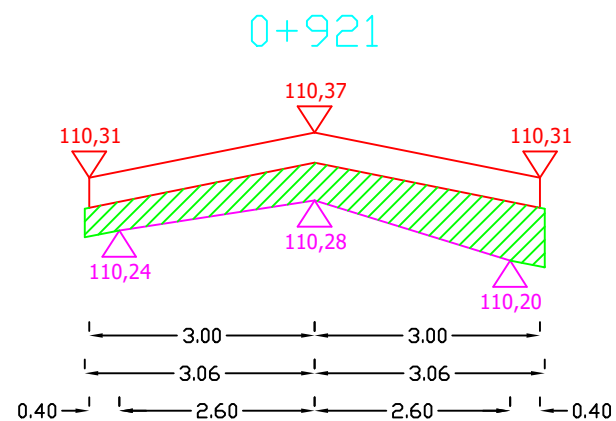

Pwyr.=0,3342 m<sup>2</sup>

Pfrez.=0,0000 m<sup>2</sup>

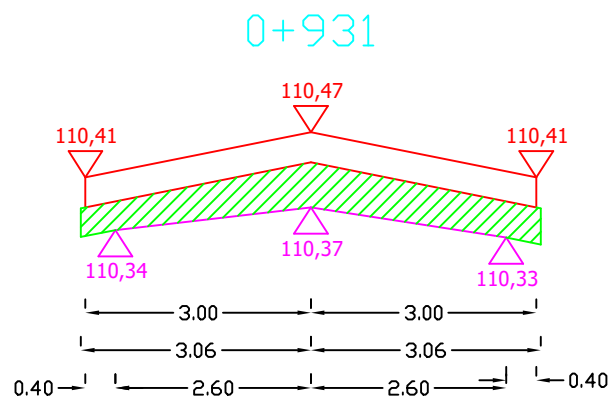

Pwyr.=0,3074 m<sup>2</sup>

Pfrez.=0,0000 m<sup>2</sup>

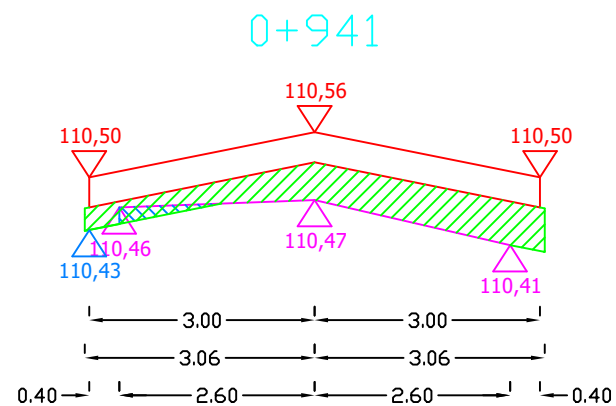

Pwyr.=0,2713 m<sup>2</sup>

Pfrez.=0,0150 m<sup>2</sup>

Sporządził:



# PRZEKROJE POPRZECZNE DROGI WOJEWÓDZKIEJ NR 651 OD KM 69+079 DO KM 70+220

SKALA 1:10/100

0+951

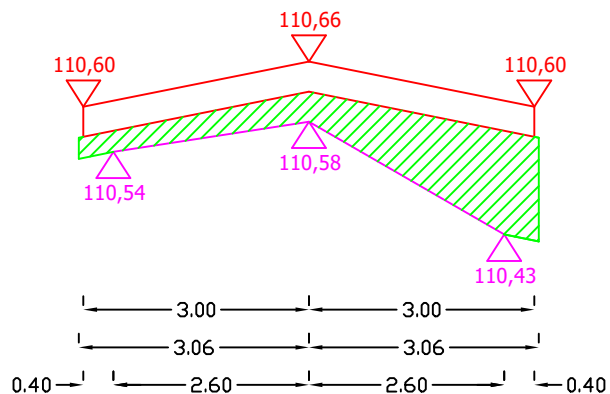

$P_{wyr.} = 0,3962 \text{ m}^2$

$P_{frez.} = 0,0000 \text{ m}^2$

0+961

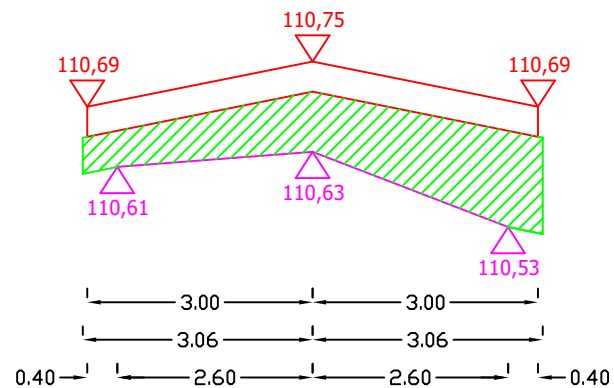

$P_{wyr.} = 0,5178 \text{ m}^2$

$P_{frez.} = 0,0000 \text{ m}^2$

0+971

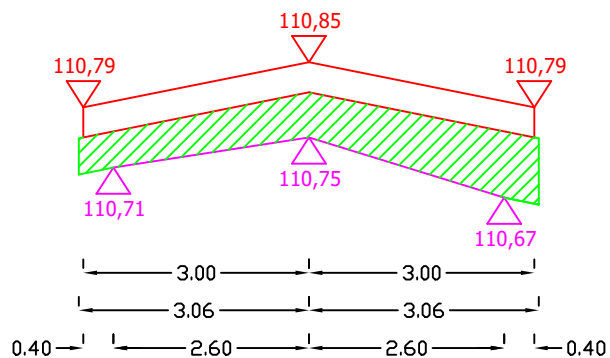

$P_{wyr.} = 0,3954 \text{ m}^2$

$P_{frez.} = 0,0000 \text{ m}^2$

0+981

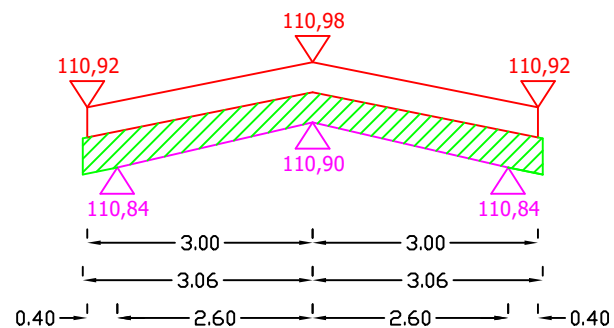

$P_{wyr.} = 0,2730 \text{ m}^2$

$P_{frez.} = 0,0000 \text{ m}^2$

Sporządził:

# PRZEKROJE POPRZECZNE DROGI WOJEWÓDZKIEJ NR 651 OD KM 69+079 DO KM 70+220

SKALA 1:10/100

0+991

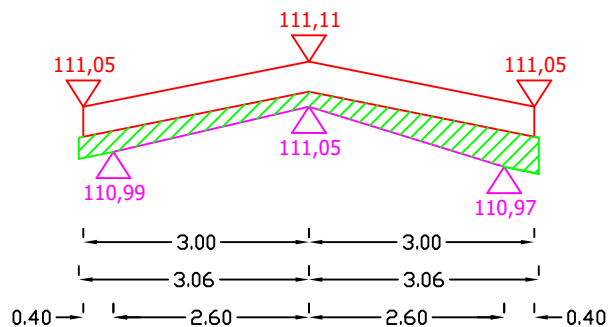

Pwyr.=0,1858 m<sup>2</sup>

Pfrez.=0,0000 m<sup>2</sup>

1+001

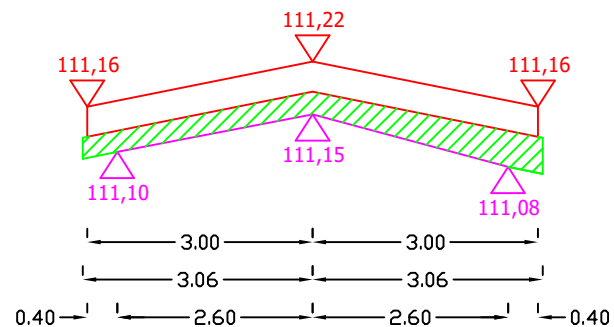

Pwyr.=0,2118 m<sup>2</sup>

Pfrez.=0,0000 m<sup>2</sup>

1+011

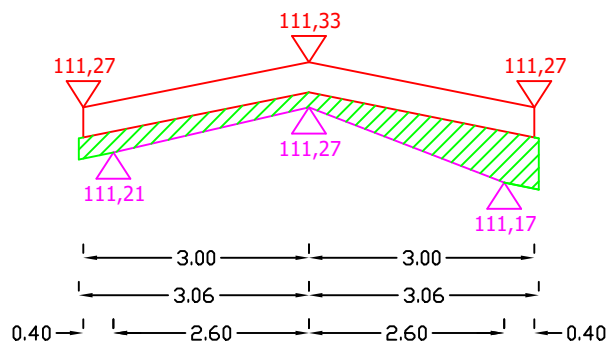

Pwyr.=0,2210 m<sup>2</sup>

Pfrez.=0,0000 m<sup>2</sup>

1+021

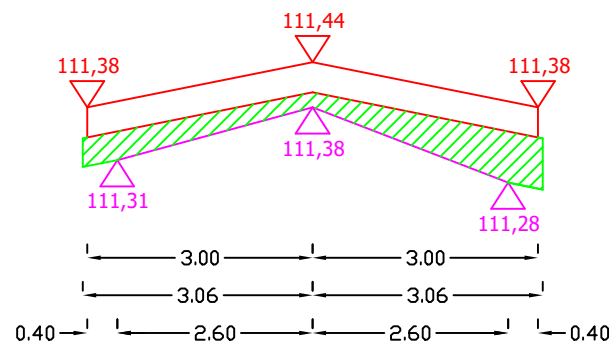

Pwyr.=0,2386 m<sup>2</sup>

Pfrez.=0,0000 m<sup>2</sup>

Sporządził:

PRZEKROJE POPRZECZNE DROGI WOJEWÓDZKIEJ NR 651 OD KM 69+079 DO KM 70+220

SKALA 1:10/100

1+031

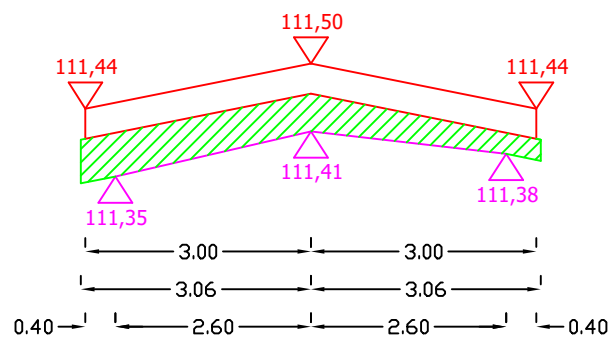

Pwyr.=0,2814 m<sup>2</sup>

Pfrez.=0,0000 m<sup>2</sup>

1+041

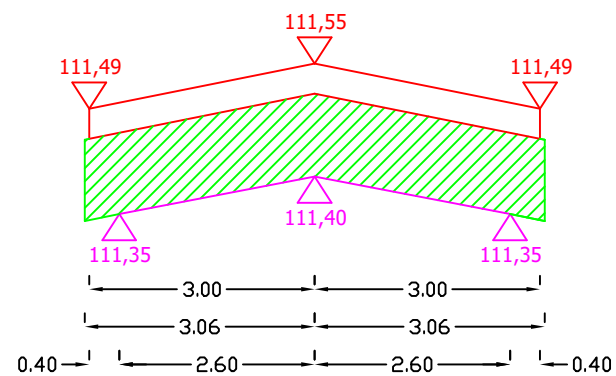

Pwyr.=0,6662 m<sup>2</sup>

Pfrez.=0,0000 m<sup>2</sup>

1+051

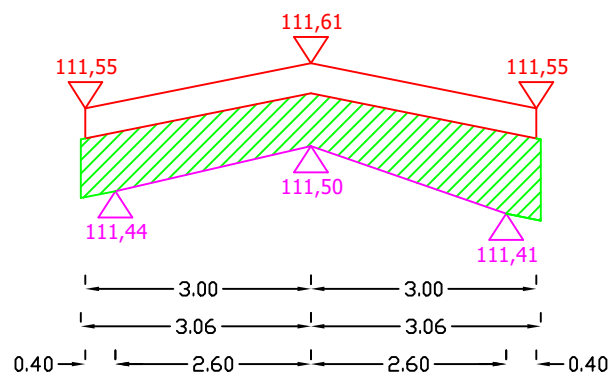

Pwyr.=0,5094 m<sup>2</sup>

Pfrez.=0,0000 m<sup>2</sup>

1+061

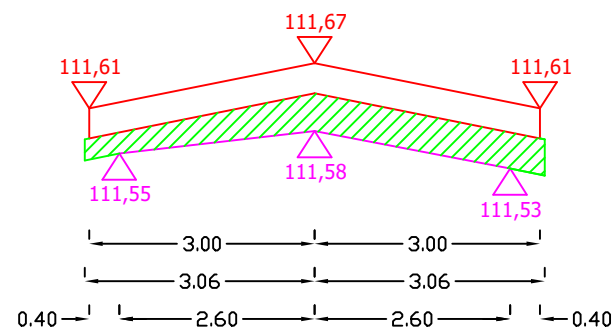

Pwyr.=0,2638 m<sup>2</sup>

Pfrez.=0,0000 m<sup>2</sup>

Sporządził:

# PRZEKROJE POPRZECZNE DROGI WOJEWÓDZKIEJ NR 651 OD KM 69+079 DO KM 70+220

SKALA 1:10/100

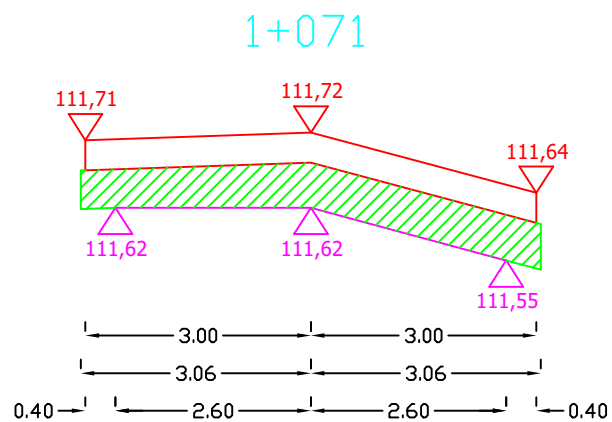

Pwyr.=0,3531 m<sup>2</sup>

Pfrez.=0,0000 m<sup>2</sup>

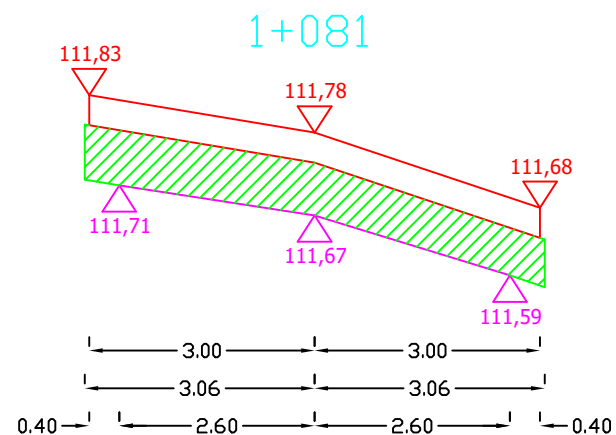

Pwyr.=0,4225 m<sup>2</sup>

Pfrez.=0,0000 m<sup>2</sup>

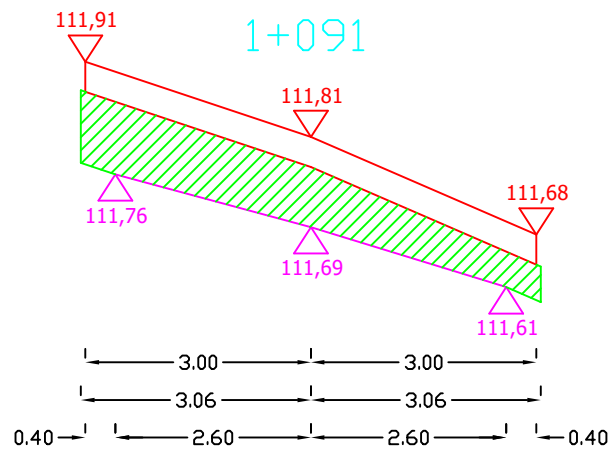

Pwyr.=0,4614 m<sup>2</sup>

Pfrez.=0,0000 m<sup>2</sup>

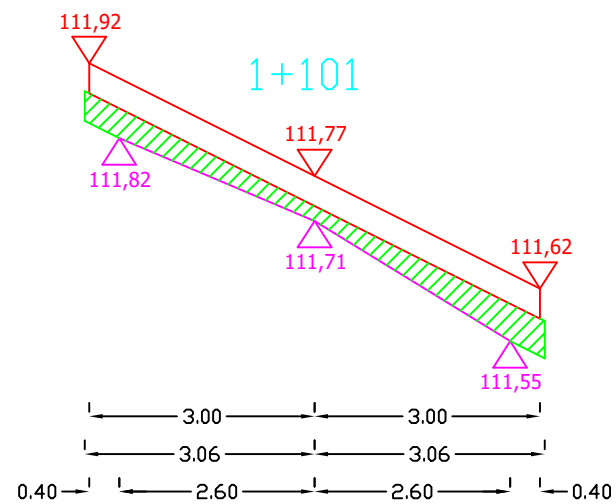

Pwyr.=0,2104 m<sup>2</sup>

Pfrez.=0,0000 m<sup>2</sup>

Sporządził:

# PRZEKROJE POPRZECZNE DROGI WOJEWÓDZKIEJ NR 651 OD KM 69+079 DO KM 70+220

SKALA 1:10/100

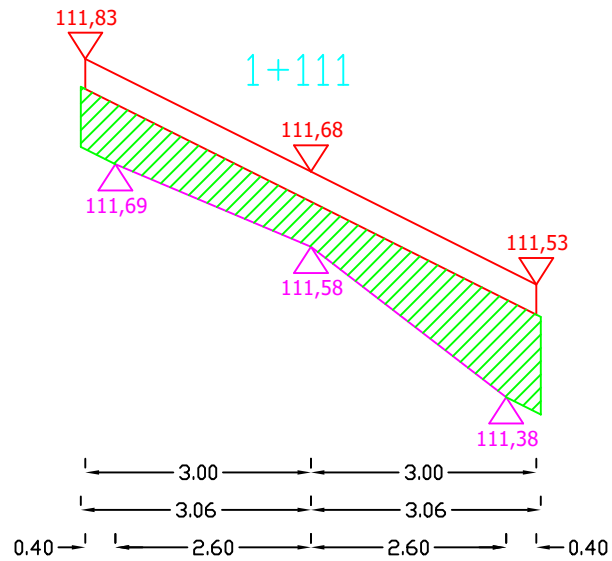

Pwyr.=0,5256 m<sup>2</sup>

Pfrez.=0,0000 m<sup>2</sup>

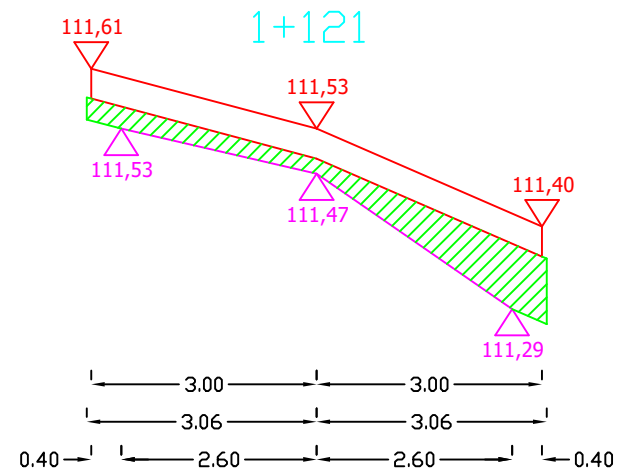

Pwyr.=0,2573 m<sup>2</sup>

Pfrez.=0,0000 m<sup>2</sup>

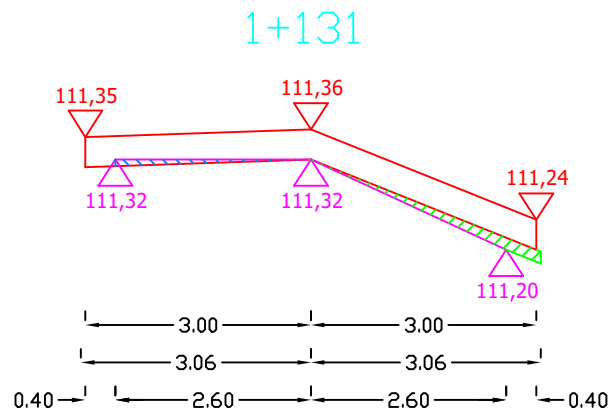

Pwyr.=0,0282 m<sup>2</sup>

Pfrez.=0,0113 m<sup>2</sup>

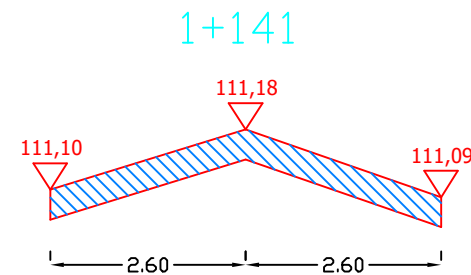

Pwyr.=0,0000 m<sup>2</sup>

Pfrez.=0,2080 m<sup>2</sup>

Sporządził: